

OWNER'S GUIDE

READ FIRST! Important Safety Precautions!

CAUTION

RISK OF ELECTRIC SHOCK DO NOT OPEN

CAUTION: To reduce the risk of electric shock, do not remove cover (or back).
No user-serviceable parts inside.
Refer servicing to qualified service personnel.

CAUTION: To prevent electric shock, do not use this (polarized) plug with an extension cord, receptacle or other outlet unless the blades can be fully inserted to prevent blade exposure.



The lightning flash with arrowhead symbol, within an equilateral triangle, is intended to alert the user to the presence of uninsulated "dangerous voltage" within the product's enclosure that may be of sufficient magnitude to constitute a risk of electric shock to persons.



The exclamation point within an equilateral triangle is intended to alert the user to the presence of important operating and maintenance (servicing) instructions in the literature accompanying the appliance.

1. Read these instructions.
2. Keep these instructions.
3. Heed all warnings.
4. Follow all instructions.
5. Do not use this apparatus near water.
6. Clean only with a dry cloth.
7. Do not block any ventilation openings. Install in accordance with the manufacturer's instructions.
8. Do not install near any heat sources such as radiators, heat registers, stoves or other apparatus (including amplifiers) that produce heat.
9. Do not defeat the safety purpose of the polarized or grounding-type plug. A polarized plug has two blades with one wider than the other. A grounding-type plug has two blades and a third grounding prong. The wide blade or the third prong are provided for your safety. If the provided plug does not fit into your outlet, consult an electrician for replacement of the obsolete outlet.
10. Protect the power cord from being walked on or pinched, particularly at plugs, convenience receptacles and the point where they exit from the apparatus.
11. Only use attachments/accessories specified by the manufacturer.
12. Use only with the cart, stand, tripod, bracket or table specified by the manufacturer or sold with the apparatus. When a cart is used, use caution when moving the cart/apparatus combination to avoid injury from tip-over.



13. Unplug this apparatus during lightning storms or when unused for long periods of time.

14. Refer all servicing to qualified service personnel. Servicing is required when the apparatus has been damaged in any way, such as power-supply cord or plug is damaged, liquid has been spilled or objects have fallen into the apparatus, the apparatus has been exposed to rain or moisture, does not operate normally, or has been dropped.

15. Do not use attachments not recommended by the product manufacturer, as they may cause hazards.

16. This product should be operated only from the type of power source indicated on the marking label. If you are not sure of the type of power supply to your home, consult your product dealer or local power company. For products intended to operate from battery power, or other sources, refer to the operating instructions.

17. If an outside antenna or cable system is connected to the product, be sure the antenna or cable system is grounded so as to provide some protection against voltage surges and built-up static charges. Article 810 of the National Electrical Code, ANSI/NFPA 70, provides information with regard to proper grounding of the mast and supporting structure, grounding of the lead-in wire to an antenna discharge unit, size of grounding conductors, location of antenna-discharge unit, connection to grounding electrodes, and requirements for the grounding electrode. See Figure A.

18. An outside antenna system should not be located in the vicinity of overhead power lines or other electric light or power circuits, or where it can fall into such power

lines or circuits. When installing an outside antenna system, extreme care should be taken to keep from touching such power lines or circuits, as contact with them might be fatal.

19. Do not overload wall outlets, extension cords, or integral convenience receptacles, as this can result in a risk of fire or electric shock.

20. Never push objects of any kind into this product through openings, as they may touch dangerous voltage points or short-out parts that could result in a fire or electric shock. Never spill liquid of any kind on the product.

21. The apparatus shall not be exposed to dripping or splashing, and no objects filled with liquids, such as vases, shall be placed on the apparatus.

22. Do not attempt to service this product yourself, as opening or removing covers may expose you to dangerous voltage or other hazards. Refer all servicing to qualified service personnel.

23. When replacement parts are required, be sure the service technician has used replacement parts specified by the manufacturer or that have the same characteristics as the original part. Unauthorized substitutions may result in fire, electric shock or other hazards.

24. Upon completion of any service or repairs to this product, ask the service technician to perform safety checks to determine that the product is in proper operating condition.

25. The product should be mounted to a wall or ceiling only as recommended by the manufacturer.

Figure A.

Example of Antenna Grounding as per National Electrical Code, ANSI/NFPA 70

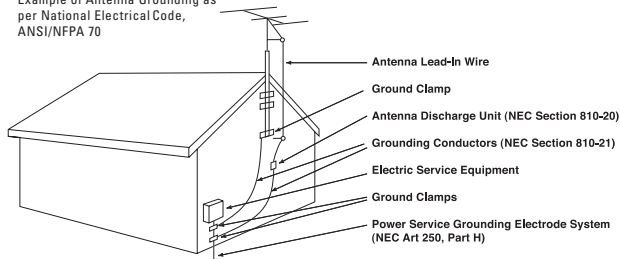

THANK YOU FOR CHOOSING JBL

For more than 50 years, JBL has been involved in every aspect of music and film recording and reproduction, from live performances to the recordings you play in your home, car or office.

We're confident that the JBL system you have chosen will provide every note of enjoy-

ment that you expected – and that when you think about purchasing additional audio equipment for your home, car or office, you will once again choose JBL.

Please take a moment to register your product on our Web site at www.jbl.com.

This enables us to keep you posted on our latest advancements, and helps us to better understand our customers and build products that meet their needs and expectations.

JBL Consumer Products

SPEAKER PLACEMENT

- **As a general rule, bass response increases as a subwoofer is placed closer to a wall. Therefore, bass output is maximized when the subwoofer is placed in a corner.**
- **It is also recommended that the subwoofer be positioned along the same wall as the front loudspeakers.**

Low-frequency sounds are normally omnidirectional, meaning the listener can't tell where they are generated from. However, frequencies between 75Hz and 150Hz can be localized, especially at higher volume levels. Positioning your subwoofer as recommended will provide the most natural soundstage and imaging from your loudspeaker system.

Remember that these are just guidelines. Since every listening room is different, JBL

strongly recommends experimenting with the positioning of your subwoofer to obtain the most pleasing results in your room. One technique that can help you find the ideal subwoofer location is to temporarily place the subwoofer near the main listening location. Then move around the room and determine where you hear the most pleasing bass performance. This would then be the ideal location for the subwoofer.

SPEAKER CONNECTION

When we designed the Balboa Sub powered subwoofer, our goal was to offer the user the best possible performance combined with the most flexible and complete installation options. Please look over the following three examples to determine which description best matches your system and follow the corresponding hookup instructions.

To use the binding-post speaker terminals with bare wire, unscrew the collar until the hole through the center post is visible under the collar. Insert the bare end of the wire through the hole in the post, then screw the collar back

down until the connection is tight. The holes in the center of the collars are intended for banana-type connectors.

To comply with European CE certification, these holes are blocked with plastic inserts at the point of manufacture. To use banana-type connectors requires the removal of the inserts. Do not remove these inserts if you are using the product in an area covered by the European CE certification.

Speakers and electronics terminals have corresponding positive (+) and negative (–) terminals. It is important to connect both speakers identically: positive (+) on the

speaker to positive (+) on the amplifier and negative (–) on the speaker to negative (–) on the amplifier. Wiring “out of phase” results in thin sound, weak bass and a poor stereo image.

With the advent of multichannel surround sound systems, connecting all of the speakers in your system with the correct polarity remains equally important in order to preserve the proper ambience and directionality of the program material.

DOLBY® DIGITAL OR DTS® (OR OTHER DIGITAL SURROUND MODE) CONNECTION

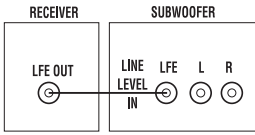

Use this installation method for Dolby Digital, DTS or other digital surround processors:

Use the line-level input jack marked "LFE" for the Low-Frequency Effects channel. Connect this jack to the LFE output or subwoofer output on your receiver or amplifier. Connect

each speaker to the corresponding speaker terminals on your receiver or amplifier.

Make sure that you have configured your surround sound processor for "Sub-woofer On." Also configure your receiver for 5.1-, 6.1- or 7.1-channel operation as appropriate. The front left, front right, center and rear speakers should all be set to "Small." If your receiver allows you to set the cross-over frequency between the subwoofer and

the main speakers, select 120Hz or the setting that is the closest frequency below it.

IMPORTANT: Do not use the LFE input on the subwoofer with Dolby Pro Logic processors.

Note for advanced users: If your receiver/processor has a built-in low-pass crossover filter for the subwoofer output, you may use the LFE input to bypass the subwoofer's internal crossover.

DOLBY PRO LOGIC® (NON-DIGITAL) - LINE LEVEL

Use this installation method for Dolby Pro Logic applications (not Dolby Digital, DTS or other digital processing), where the receiver/processor is equipped with a subwoofer output, or a volumecontrolled preamp (line-) level output:

Use RCA-type interconnects to connect the line-level subwoofer outputs on your receiver or amplifier to the line-level inputs on the subwoofer.

IMPORTANT: Do not use the LFE input on the subwoofer with Dolby Pro Logic processors.

NOTE: If your receiver or amplifier only has one subwoofer output jack, then you will need to use a Y-connector (not included).

Plug the male end of the Y-connector into your receiver or amplifier's subwoofer output jack, and connect each of the two female ends to separate RCA-type interconnects.

Finally, plug the RCA-type interconnects into the line-level inputs on the subwoofer.

Connect each speaker to the corresponding speaker terminals on your receiver or amplifier.

Note for advanced users: If your receiver/processor has a built-in low-pass crossover filter for the subwoofer output, you may use the LFE input to bypass the subwoofer's internal crossover.

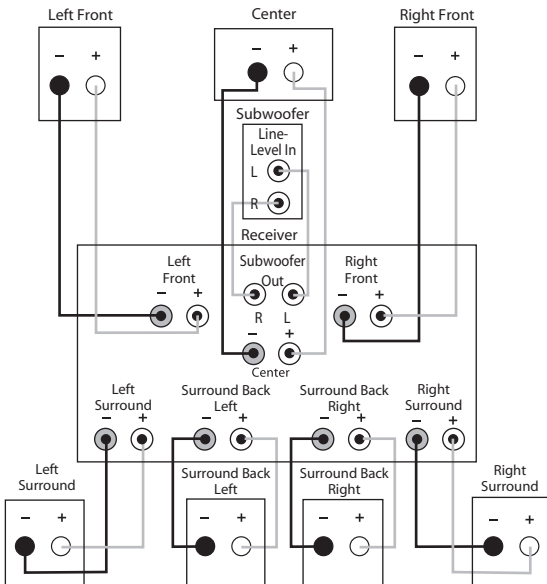

DOLBY PRO LOGIC (NON-DIGITAL) - SPEAKER LEVEL

Use this installation method for Dolby Pro Logic applications (not Dolby Digital, DTS or other digital processing), where the receiver/processor does not have a subwoofer output, or a volume-controlled preamp (line-) level output:

Connect your receiver or amplifier's front left and right speaker terminals to the left and right terminals on the subwoofer that are marked "Speaker Level In." Connect the left and right terminals on the subwoofer that are marked "Speaker Level Out" to the corresponding terminals on the back of your front left and right speakers.

Connect your receiver or amplifier's center, surround and surround back speaker terminals to the corresponding terminals on the back of your center and surround speakers.

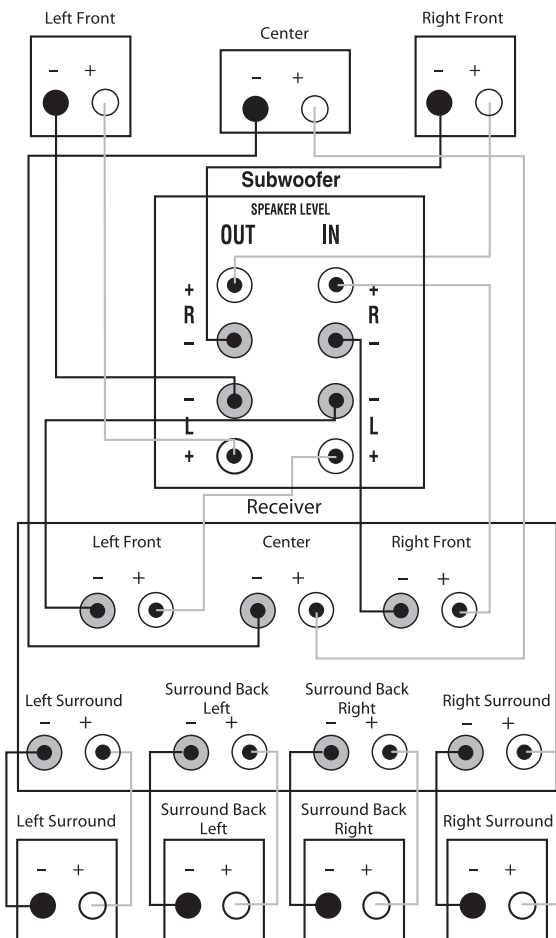

OPERATION

POWER

Move the Master Power switch (marked "Power" **A**) to the "1" (On) position to use the Balboa Subwoofer.

If you will be away from home for an extended period of time, or if the subwoofer will not be used, switch the Master Power

switch **A** to the Off position.

LEVEL CONTROL

The subwoofer Level Control **D** adjusts the volume of the subwoofer relative to the rest of the system. Proper level

adjustment depends on several variables such as room size, subwoofer placement, type of main speakers and position.

Adjust the subwoofer level so that the volume of the bass information is pleasing to you.

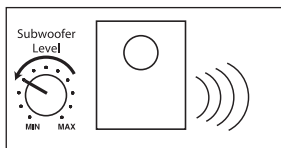
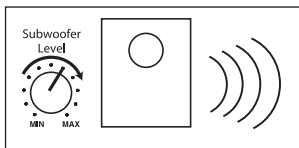

CROSSOVER ADJUSTMENTS

The Crossover Frequency Control **C** determines the highest frequency at which the subwoofer reproduces sounds. If your main speakers can comfortably reproduce some low-frequency sounds, set this control to a lower frequency setting, between 50Hz and 100Hz. This will concentrate the subwoofer's efforts on the ultradeep bass sounds required by today's films and music. If you are using smaller bookshelf speakers that do not extend to the lower bass frequencies, set the low-pass crossover control to a higher setting, between 120Hz and 150Hz. This control is not used when the LFE switch is in the "LFE" position.

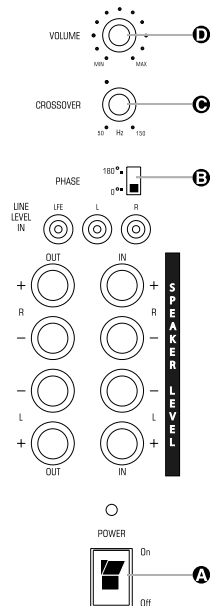

JBL BALBOA SUB/230
JBL Incorporated
 A Harman International Company

This area is designed to become quite warm during normal operation.



WARNING: TO REDUCE THE RISK OF FIRE OR ELECTRIC SHOCK, DO NOT EXPOSE THIS APPLIANCE TO RAIN OR MOISTURE.
AVERTISSEMENT: POUR PREVENIR LES RISQUES CONCERNANT LE CHOC ELECTRIQUE, EVITER D'EXPOSER CET APPAREIL A LA PLUIE OU A L'HUMIDITE.

PHASE CONTROL



The Phase Control **ⓔ** determines whether the subwoofer's piston-like action moves in and out in phase with the main speakers or opposite the main speakers. There is no correct or incorrect setting. Proper phase adjustment depends on several variables such as subwoofer placement and listener position. Adjust the

phase switch to maximize bass output at the listening position.

Remember, every system, room and listener is different. There are no right or wrong settings; this switch offers the added flexibility to adjust your subwoofer for optimum performance for your specific listening conditions without having to move your speak-

ers. If at some time in the future you happen to rearrange your listening room and move your speakers, you should experiment with the phase switch in both positions, and leave it in the position that maximizes bass performance.

TROUBLESHOOTING

If you used the high-level (speaker) inputs and there is no sound from any of the speakers:

- Check that the receiver/amplifier is on and a source is playing.
- Check that the powered subwoofer is plugged into an active electrical outlet and is switched on.
- Check all wires and connections between the receiver/amplifier and the speakers. Make sure all wires are connected. Make sure none of the speaker wires are frayed, cut or punctured, or touching each other.
- Review proper operation of your receiver/amplifier.

If there is low (or no) bass output:

- Make sure the connections to the left and right "Speaker Inputs" have the correct polarity (+ and -).
- Make sure that the subwoofer is plugged into an active electrical outlet and switched on.
- Adjust the crossover point.
- Flip the Phase Control switch to the opposite position.
- If you are using a Dolby Digital/DTS receiver or processor, make sure that the subwoofer adjustments on the receiver/processor are set up correctly.
- Slowly turn the Level Control clockwise until you begin to hear the desired amount of bass.

If you used the line-level inputs and there is no sound from the subwoofer:

- Check that the receiver/amplifier is on and a source is playing.
- Check that the powered subwoofer is plugged into an active electrical outlet and is switched on.
- Check all wires and connections between the receiver/amplifier and the subwoofer. Make sure all wires are connected. Make sure none of the wires are frayed, cut or punctured, or touching each other.
- Review proper operation of your receiver/amplifier.
- Slowly turn the Level Control clockwise until you begin to hear the desired amount of bass.
- Make sure that you have configured your receiver/processor so that the subwoofer/LFE output is on.

SPECIFICATIONS

BALBOA SUB

Amplifier Power (RMS):	100 Watts
Peak Dynamic Power †:	225 Watts
Driver:	200mm (8") Pure-cellulose-fiber cone
Inputs:	Line-level, LFE and speaker-level with 5-way binding posts
Low-Pass Frequency:	Variable from 50Hz to 150Hz
Frequency Response:	35Hz – Low-pass crossover setting (-6dB)
Dimensions (including feet) (H x W x D):	413mm x 279mm x 349mm
Weight:	13.6kg

† The Peak Dynamic Power is measured by recording the highest center-to-peak voltage measured across the output of a resistive load equal to minimum impedance of the transducer, using a 50Hz sine wave burst, 3 cycles on, 17 cycles off.

Declaration of Conformity



We, Harman Consumer Group International
2, route de Tours
72500 Chateau-du-Loir
France

declare in own responsibility that the product described in this owner's manual is in compliance with technical standards:

EN 55013:2001+A1:2003
EN 55020:2002+A1:2003
EN 61000-3-2:2000
EN 61000-3-3:1995+A1:2001
EN 60065:2002

Gary Mardell
Harman Consumer Group International
Chateau-du-Loir, France 1/05

JBL PRO SOUND COMES HOME™

JBL Consumer Products, 250 Crossways Park Drive, Woodbury, NY 11797
8500 Balboa Boulevard, Northridge, CA 91329
www.jbl.com

© 2005 Harman International Industries, Incorporated

JBL is a registered trademark of Harman International Industries, Incorporated.

A Harman International Company

Part No. 406-000-05178

*Trademarks of Dolby Laboratories.

DTS is a registered trademark of Digital Theater Systems, Inc.

All features and specifications are subject to change without notice.