

Enigma Veyron Loudspeaker User Guide

EV-1D-1.1

Table of content

3	Preface
4	Introduction to the Enigma Veyron System
6	Part list
7	Unpacking Loudspeaker
16	Connection
17	Optimization
20	Specifications
21	Dimensions
22	Warranty

Preface

Congratulations,

You are now the owner of a Kharma Enigma Veyron Loudspeaker. Your new loudspeaker, properly installed, will give you all the satisfaction and enjoyment you expect from Kharma.

As with any high quality product, special care must be taken to install your loudspeaker. Please read this manual carefully and totally prior to installation.

Important Please read the manual thoroughly before taking further steps.

Introduction to the Enigma Veyron

Above and beyond imagination has always been the core value of Kharma, which now results in the Kharma Enigma Veyron System. Charles van Oosterum has created the Enigma Veyron System on his journey to create the ultimate audio experience. He has combined technology, experience and knowledge to uplift sound representation to an unknown level of synergy.

The Kharma Enigma Veyron system is the most advanced audio system in the world realizing the Holy Grail in the High-end audio. To create a new level of sound quality and truly offer superior technology that would push the limits of current dynamic loudspeakers was not an easy task. This time fully new engineered Kharma drivers are the basis of the Enigma Veyron, as well as a new cabinet, materials, internal cable technology and more. We decided to offer the whole package to drive the full Enigma Veyron as well. New wide band linear power amps, a complete new touchscreen operated pre-amp, App controlled subwoofer management and massive power distributors as well as a diamond suspended audio rack were developed. Hence many exciting innovations were developed by Kharma to create this unique audio system.

The bass and midrange section of the Veyron are formed by the exclusive Kharma Omega 7-F Drivers. The F stands for 0-Foucault currents, which is a novelty in the audio world, because for the first time no iron is used in the magnet motor-system, avoiding any interaction. Normally the voice coil induces a Foucault-current into the iron parts and that current induces back distortion into the driver-coil which will distort the original signal by definition. This is now completely gone and the result is a higher resolution, more micro-dynamics, more macro-dynamics, faster transients, more richer spectrum of tonal variations from the music itself, more natural sounding, more explosive sounding, more realistic sounding.

Moreover, Kharma created the largest Diamond cone surface ever used in a loudspeaker. To create extreme resolution and dispersion for the upper mid and lower high frequency Kharma has used 4 x 50 mm diamond tweeters. For the ultimate clear high frequencies, far beyond hearing, four Diamond tweeters of 25 mm are being used. These 8 tweeters with a combined surface of around 400 square centimeters are just for one loudspeaker.

The Enigma Veyron System has magical physical dimensions, which are as impressive as the musical performance this loudspeaker has to offer. The loudspeaker cabinets are constructed from 100 mm thick Bullet wood panels and the audio rack and electronics from 38 mm thick aluminium plates. Although the constructions are massive but elegant, all components are decoupled from the surrounding by a minimum contact surface created with Tungsten balls placed on Diamonds. The combination of the hardness, shape and acoustical properties of the materials used, realize the ultimate freedom of resonances.

Kharma has pushed the limits for each component of the Enigma Veyron system. The sound representation and aesthetical beauty is overwhelming and certainly beyond imagination.

Part list

The Enigma Veyron Loudspeaker comes in 2 crates for a pair:

The two crates contain:

- 2 x EV-1D-1.1 loudspeaker
- 2 x Top cover for loudspeaker
- 8 x M10 Bolts
- 2 x Tilting accessory
- 2 x Set movers (1 for hard floor / 1 for carpet floor)
- 1 x Manual

Important Please first read the manual before taking further steps.

Unpacking Loudspeaker

Opening the crate

Upon opening the crate, inspect the crate carefully for any sign of transport damage. If there is damage, immediately call your dealer or the trucking firm that made the delivery. Do not delay in reporting the damage. Please store the crates for future use.

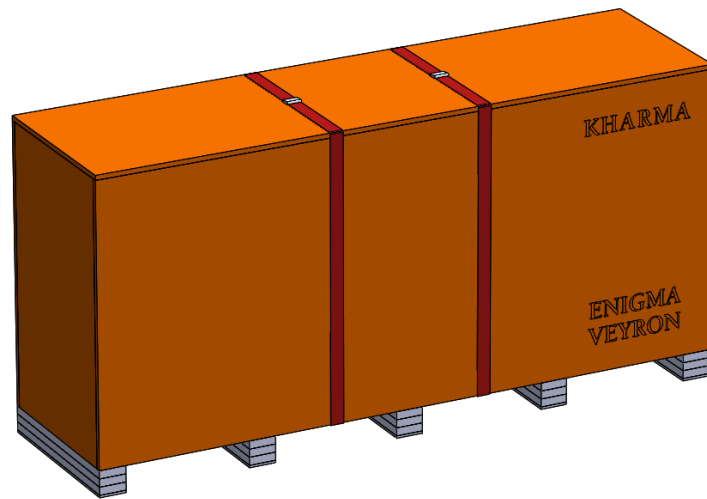

Step 1: Remove top cover

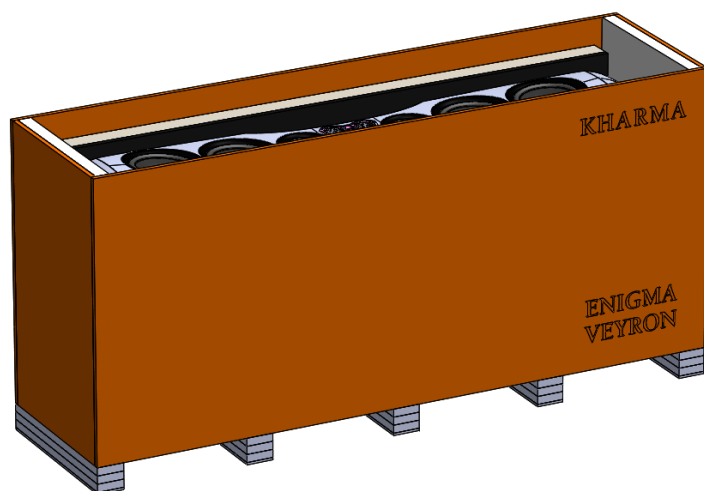

Step 2: Unscrew all side panels

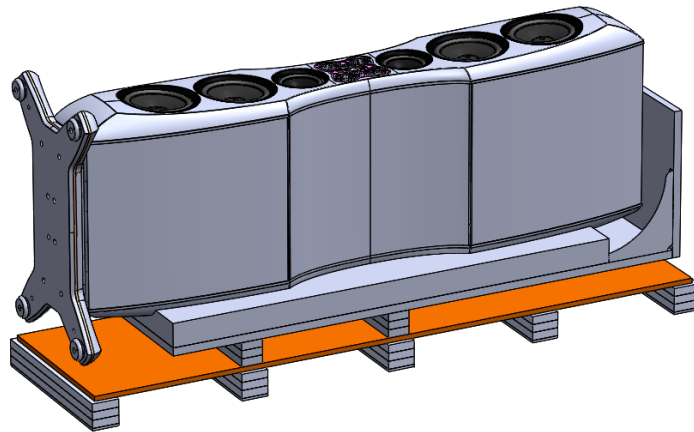

Step 3: Keep the speaker fixated

Do not unscrew the panel that is fixated on the loudspeaker. This is required to tilt the loudspeaker.

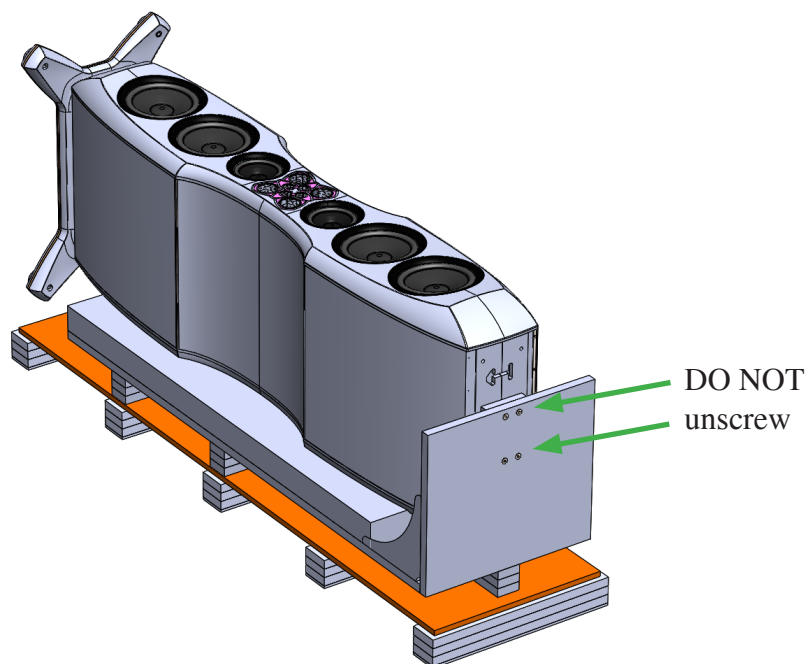

Step 4: Lift loudspeaker from pallet

The openings indicated with the green arrows can be used in combination with a hoist structure or forklift. Please always check the balance of the hoist structure before lifting the loudspeaker completely.

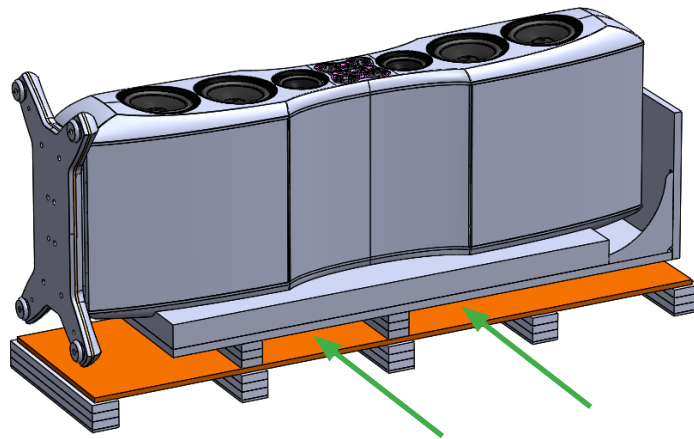

Step 5: Move loudspeaker to destination

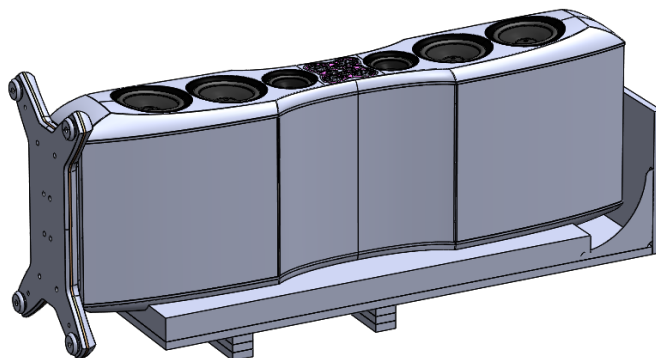

Step 6: Apply protection

During tilting there will be a heavy force applied on the floor. To protect as well the floor as the stand, please use a protective plate on the floor.

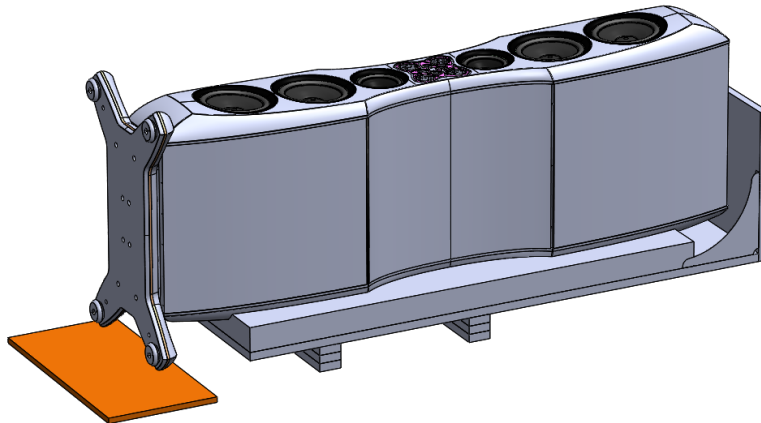

Important

When tilting more than 500 kg will be divided over only two points, please make sure the floor is protected properly.

Step 7: Prepare tilting

The loudspeaker can be tilted in two different ways: by hand or with a forklift truck. For both hold that the crate part should still be fixated at the top of the speaker. There is a tilting accessory to protect the stand during tilting, make sure this is placed correctly.

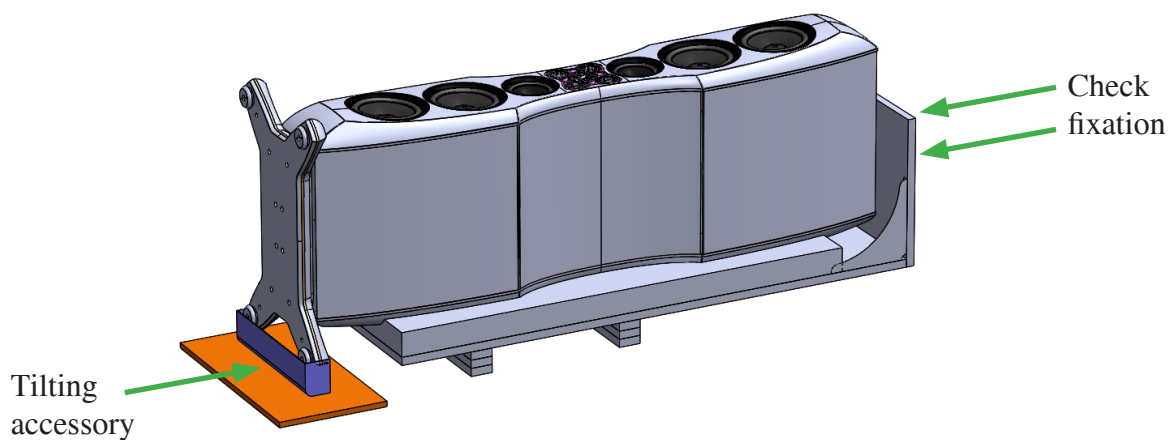

Important

DO NOT lift the loudspeaker itself, but hold on to the crate part. Moreover, make sure the crate part is still fixated at the top of the speaker.

Step 8a: Tilting with forklift truck

The crate has one beam placed in the length of the speaker, such that a forklift truck can be shoved under the crate at the top of the speaker. By moving the forklift truck up and forward, the speaker can be tilted easily.

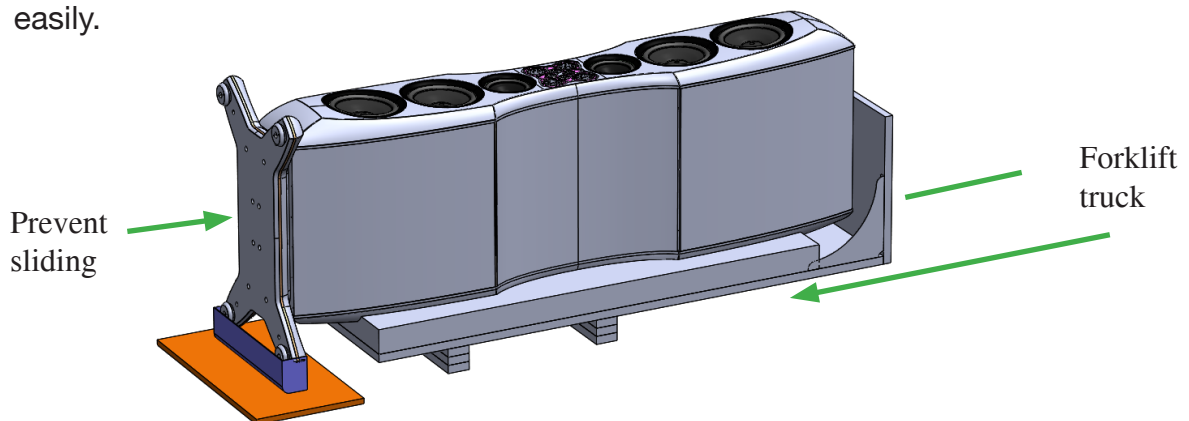

Important

Please make sure enough people are present to monitor the process and can correct when required.

Step 8b: Tilting by hand

Please tilt the loudspeaker with a minimal of 6 people: 2 people at each side of the loudspeaker, 1 at the top of the loudspeaker and 1 to prevent the loudspeaker sliding away.

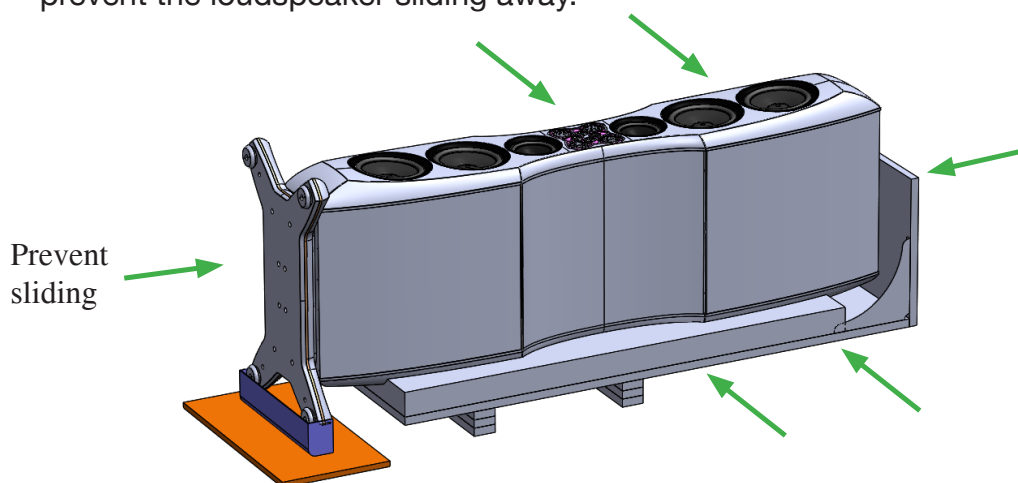

Important

DO NOT lift the loudspeaker itself, but hold on to the crate part. Moreover, make sure the crate part is still fixated at the top of the speaker.

Step 9: Start tilting

The crate part should stay on the loudspeaker until it's standing upright.

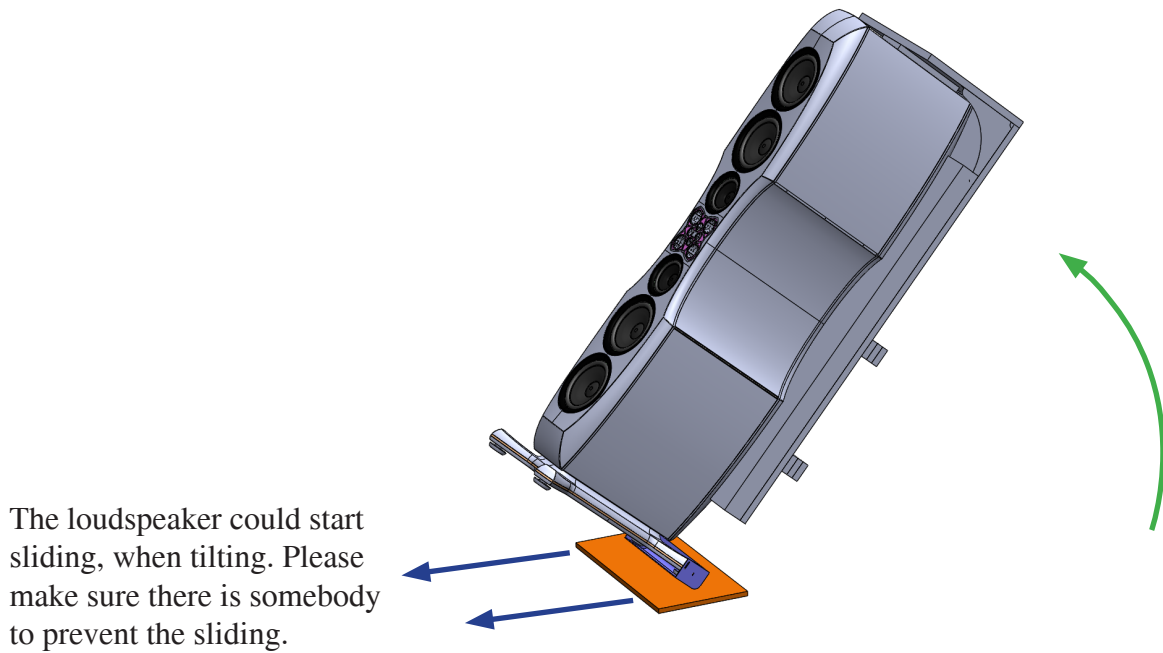
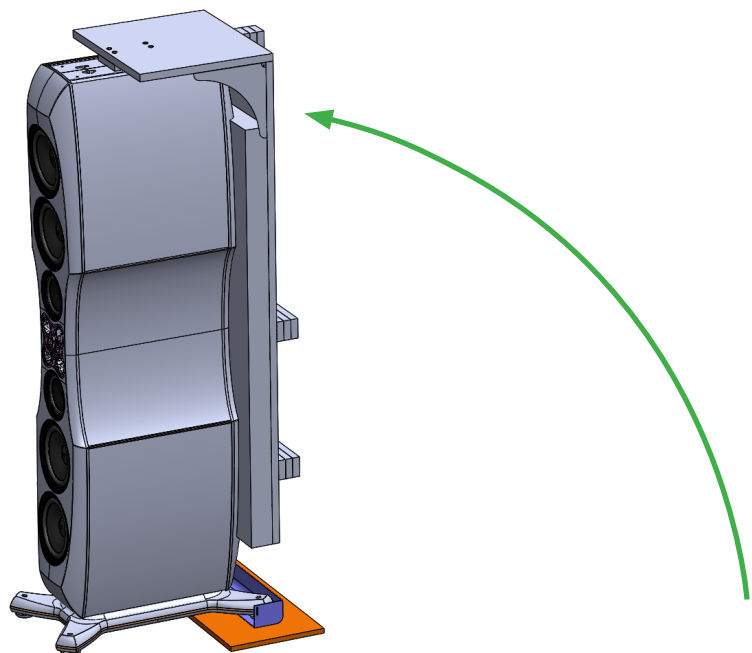
**Step 10: Tilt until loudspeaker is upright**

Step 11: Remove crate part

The crate part is fixated at the top with four bolts. Remove the bolts, while holding the crate part. When the crate part is loose, lift the part from the loudspeaker.

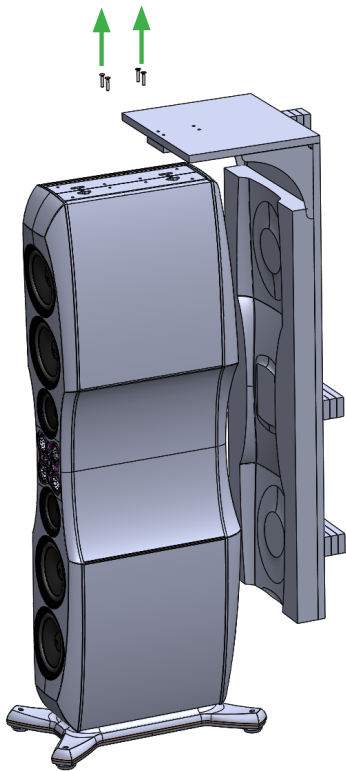

Step 11

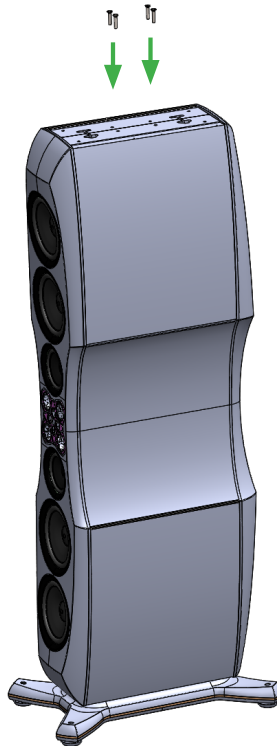

Step 12

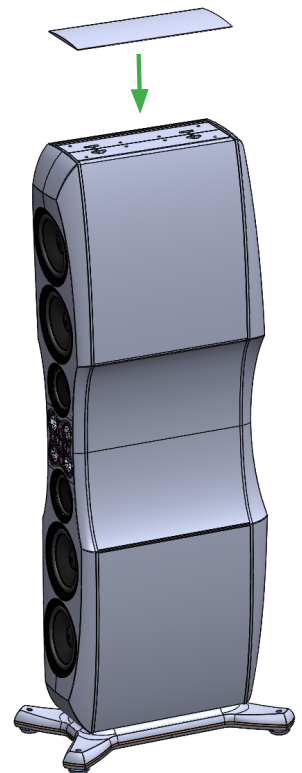

Step 13

Step 12: Place supplied bolts

There are 4 bolts supplied per speaker to screw on the top of the speaker.

Step 13: Attach top plate

The top plate can now be fixated on the top of the loudspeaker.

Step 14: Remove protective plate and position loudspeaker

The protective plate can be removed underneath the loudspeaker by tilting the loudspeaker a bit. The loudspeaker can now be positioned more precisely around with the supplied movers .

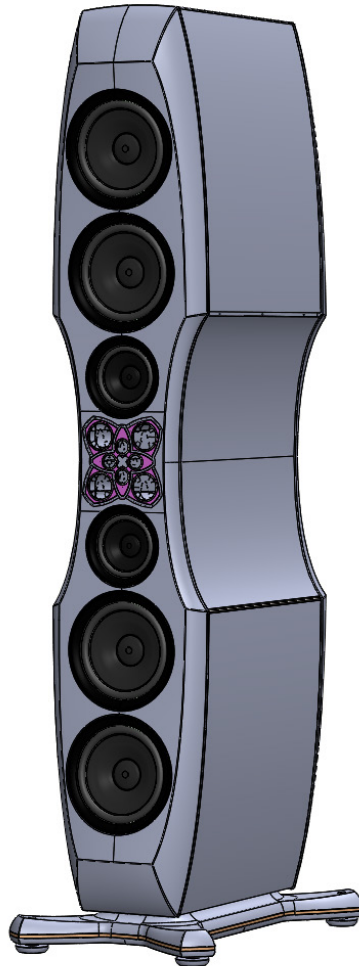

Step 14: Level speaker

The speaker has a stand with integrated Diamond suspension. The discs are already part of the stand and don't need adjustments. A hex key can be used to level the speaker. By inserting the hex key at the top of the stand and turning the hex key, the stand leg moves up or downwards. In this way all four legs can be adjusted to level the speaker.

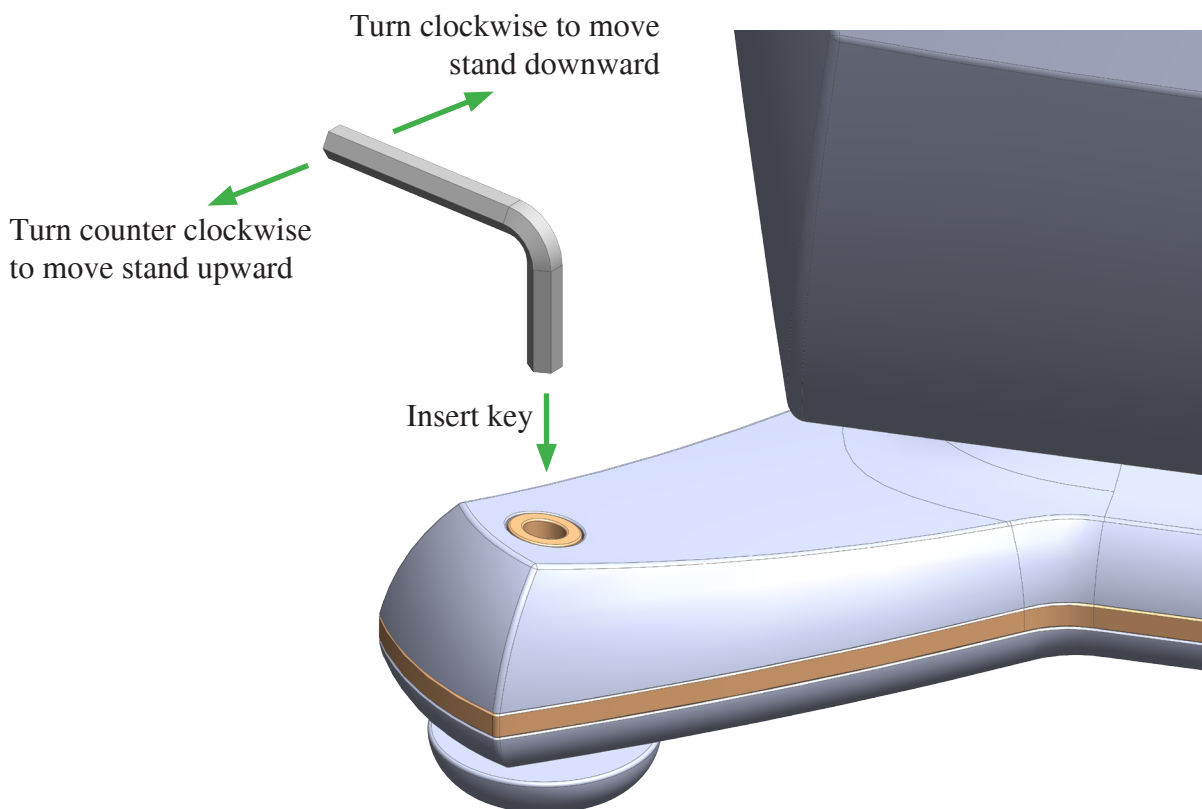

Important

Do not unscrew parts at the bottom of the stand, this will disassemble the stand and makes the stand instable.

Important

Please turn discs as close as possible to the stand when transporting the speaker in horizontal position. This is to make sure the internal Diamond-carborundum construction is fixated during transport.

Connection

At the rear of the Enigma Veyron Loudspeaker the Kharma Connection Terminals can be found. Before using the loudspeakers, remove the wires that shortcut the connectors. These wires are placed so the units will not move during transport and have less chance of being damaged.

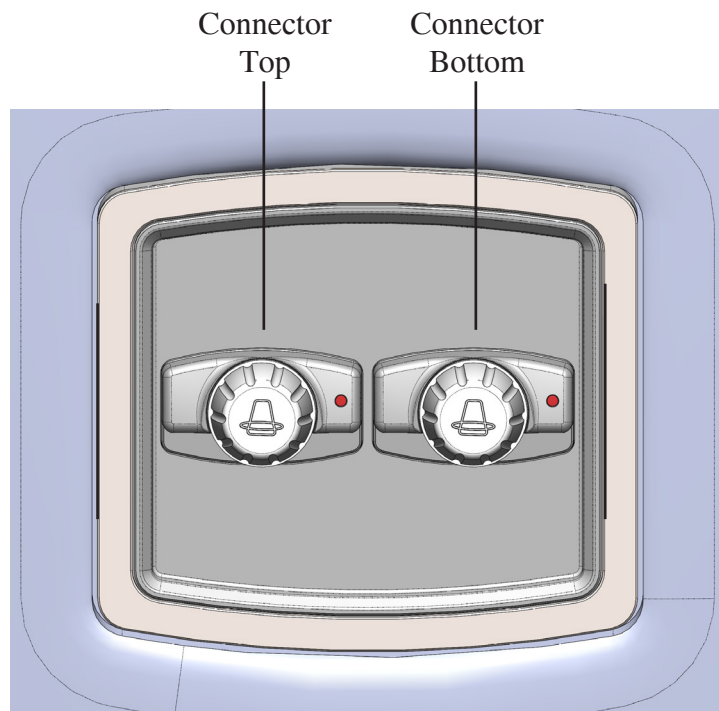

The Enigma Veyron requires bi-amping, because the loudspeaker is a double 4-way system. The left connector drives the upper part and the right connector the lower part of the loudspeaker. When only one connector is used, only half of the loudspeaker will play.

Be sure you use the same brand, type and length of loudspeaker cable on each channel. Mixing different types and/or lengths of loudspeaker cable can upset the precise timing and balance of your loudspeaker.

Optimization

Room Acoustics

A good listening room has just the right amount of reflection and absorption. The performance of any loudspeaker depends upon the speaker's location in the room and the acoustical conditions in that part of the room. Furnishing, size and proportions all effect tonal balance, imaging and bass characteristics.

In order to test the sonic balance of your room, stand in the location where the loudspeaker will be installed and clap your hands two or three times. If the room is reverberant, you will hear a sharpness or echo. If the room is dull, the sound of the clap will decay rapidly and there will be little or no echo. Large areas of glass, mirrors and wood-panelling will reflect sound waves and often result in brittleness and extreme brightness.

You can correct this by breaking these sound-waves with softer surfaces; for instance, draperies or wall hangings. In general try to create random reflections. We advise you to take your time positioning the loudspeakers. Experimenting with this will be well worth the effort.

Positioning your Enigma Veyron Loudspeaker

As said before we recommend experimenting with loudspeaker placement in order to obtain the best spectral balance, openness and perception of depth. For good results, the loudspeakers should be no closer than 45 cm from the rear wall with at least 70 cm to the side walls. The space between the loudspeakers should be free. Ideally the space should be symmetrical in the area around your loudspeakers.

Moving the system towards a wall will increase bass level while generally reducing openness. Moving loudspeakers too far into the room can result in a “thin” overall presentation with loss of bass foundation. The loudspeakers will normally work well straight out and not angled toward the listener for accurate sound staging. The wide dispersion of the Enigma Veyron loudspeaker makes this possible. It is easier to carry out room changes before installing the cone feet which thread into the base.

After an approximate position is found, install the feet. If the system is operated without feet, some loss of airiness will occur. Many have found the best room position to be along an undraped longer wall, with the loudspeakers as far apart as the listener is for them.

Burn-In

The Enigma Veyron Loudspeaker needs quite a bit of playing time to reach maximum result. The use of a Burn-in test-CD is recommended to speed up this process. With a “burn-in” test CD like the XLO or Sheffield-lab CD, burn-in time is reduced to approximately 50 hours. After burning-in your system, you can play demagnetising tracks for maximum clarity. Your system will then be optimised and sound more open, more detailed and will display a more natural musical warmth.

Taking care of your loudspeaker

Use a soft cloth and a spray-cleaner to clean the surface and wood-sides. No further care is necessary.

In event of trouble

Note that you can use your amplifier’s two channels of information for simple troubleshooting. If the sound quality is distorted, listen to each loudspeaker separately to check if the fault is present in both. If it is, then the trouble is likely to be elsewhere in your system. If the fault is in one channel only, reverse the outputs from your amplifier to the loudspeakers (right-to-left and left-to-right). If the distortion moves to the other channel, the fault is not the loudspeaker. This technique may also be used to locate a fault between the signal source and preamp/receiver and/or between preamp and power amp(s).

If you have been unsuccessful in locating the specific source of trouble (or if you have located it, but have been unable to correct it): Consult the Authorized Kharma-dealer from whom you purchased the system. Kharma Dealers are audio specialists and can be of great assistance.

Important

Do not attempt to repair the Enigma Veyron Loudspeaker yourself. You will loose your warranty on the product.

Specifications

Type:	EV-1D-1.1
System:	Double 4-way system
Features:	Triple Diamond Stand
Frequency Range:	23 Hz - 90 kHz
Sensitivity 2.83V/1m:	97 dB
Max. SPL:	127 dB
Nominal impedance:	4 Ohm
Minimal impedance:	2.3 Ohm
Nominal power:	1000 Watt
Peak power:	2000 Watt
Connection	Double Kharma Connection Terminal

Drivers

High-frequency:	4 x 1-inch Diamond concave tweeter
High / Mid-frequency:	4 x 2-inch Diamond concave tweeter
Mid-frequency	2 x 7-inch Kharma Omega-F Driver
Low-frequency:	4 x 11-inch Kharma Omega-F Driver

Dimensions

Dimensions including stand

Height	2273 mm / 89.5 inch
Width	558 mm / 22.0 inch
Depth	922 mm / 36.3 inch

Dimensions excluding stand

Height	2179 mm / 85.8 inch
Width	420 mm / 16.5 inch
Depth	790 mm / 31.1 inch

Nett weight **500 kg / 1102 lbs**

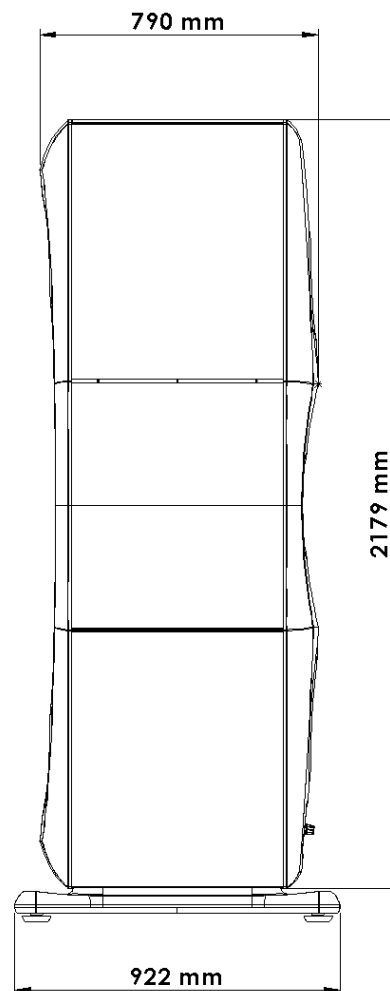
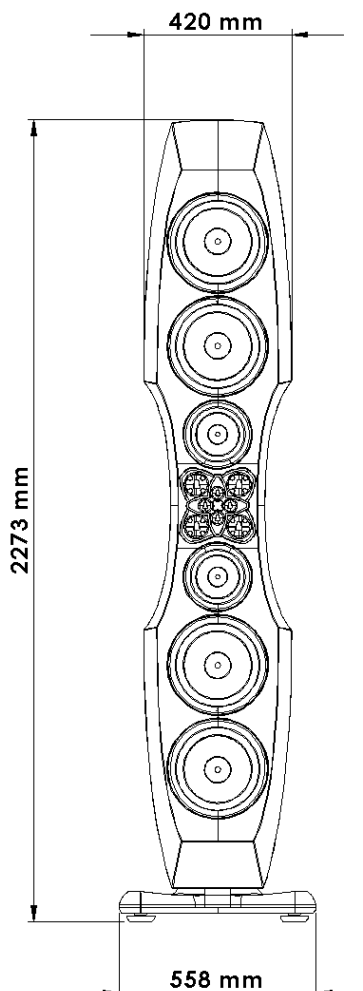

Warranty

Warranty coverage

The Kharma distributor guarantees the proper mechanical and electrical functioning of its products for a period of 5 years. Provided the warranty request card is properly filled out and sent to the address on the warranty form, including a copy of the original bill of sales. Should the customer fail to meet the three requirements mentioned above, the warranty will be limited to a period as required by national law only.

In case of malfunction the customer has to present the Kharma product in its original packing to an authorized dealer. If qualified service appears inevitable, the dealer will ship the product to an appointed service station or to the factory, depending on the required service. This warranty includes parts and labour. This warranty is not automatically transferable; subsequent owners can request a warranty at the factory.

Warranty exclusion

1. Transportation damage, visible or hidden. Damage should be reported immediately to the transport company. Registration of the complaint should be sent to the Kharma distributor previously mentioned.
2. Scratches in painted and metal surfaces. Complaints should be registered at the dealer within three days after the sale.
3. Damage due to illicit handling and inappropriate use.
4. Transportation costs to service station or factory.
5. Damage through unauthorized repair and or modification.
6. Subsequent damage to other appliances.
7. Refund of costs in case of unauthorized repair.
8. Malfunctions caused by use for commercial or professional purposes.
9. All claims on Kharma products obtained through unauthorized sources, with or without correct serial numbers.