

LEGACY

Owners Manual For The
Harmony
Loudspeaker System



Table of Contents

Registration

- 3. Owners Record
- 4. The Cabinetry / Our Commitment

Setup

- 5. Unpacking Your Speakers
- 6. Speaker Installation
- 17. Hook up Cables
- 20. Amplification

Technology

- 23. Designer's Note
- 24. Specifications

Owners Record

The model and serial numbers are located on the rear of the unit. Record these numbers in the spaces provided below. Refer to them when calling upon your dealer regarding this product.

Model No. _____

Serial No. _____

Date of purchase: _____

Thank you for selecting a Legacy Loudspeaker System. These hand-crafted instruments will provide you with many years of listening enjoyment. Please take a few moments to read this brief manual to insure maximum benefit from your speaker system.

The Cabinetry / Our Commitment

Handcrafted

Beneath the surface of Harmony elegant exterior lies rigid MDF construction. Interlocking joinery maximizes the strength of the cabinet parts. Polyester fiberfill is selected for internal damping. A sharp rap on the enclosure will leave you with little more than bruised knuckles.

Each cabinet is impeccably finished on all exposed surfaces with select veneers. The exquisite finish is hand-rubbed several times to assure a patina at home with the most elegant decor.

Our Commitment

A great deal of forethought, love and satisfaction is instilled in each piece of Legacy workmanship. We take pride in getting to know many of our customers on a first name basis.

Your purchase of this product is backed by the renowned “Legacy Satisfaction Guarantee”.



Unpacking Your Speakers

Your new speaker system has been very carefully packaged to insure that it travels to you safely. Each speaker is protected by a double-wall outer carton with heavy V-board corner protectors. Molded foam end caps are used to protect the elegant cabinetry, and a plastic liner is provided as waterproofing. Please save this packing for future transportation. If cartons become damaged or misplaced, new ones can be purchased from Legacy Audio.

Speaker Installation

Precautions

If you have any doubts about your ability to properly install in-wall loudspeakers, you should consider the services of a custom installer. If you plan to install them yourself, always use high quality tools to save time and make the installation go more smoothly.

The Harmony In-Wall Loudspeakers mount into standard 4-inch (or greater) stud depth walls. Determine the final location of both left and right speakers before cutting any holes since changes to one speaker may affect the other either aesthetically or acoustically. Look for pipes, wiring or any other conflicting material that might be damaged before beginning the installation.

WARNING: Wear Eye Protection when cutting drywall.

Also be certain there are no electrical, water, heating, or gas lines inside the wall in the location you plan to mount your Harmony loudspeakers.

Speaker Installation

Installing the Harmony In-Wall Loudspeakers

Packing List

Harmony Speaker

Installation Manual

(2) Support Blocks

(4) Support Block Screws

(2) Tensioning Screws

Tools Required

Pencil

Drywall Saw

Level

Phillips Screwdriver

Tape Measure

Mallet

Speaker Installation

Due to Harmony's unique patent pending design, Installation is identical for new or existing construction. The Harmony speaker is designed to perform at its best when the bottom of the speaker is located well off the floor (about 2.5 feet). While it may be installed at greater heights, it will perform most optimally if the variance is kept within 6" of this height. When wiring, it is useful to leave several extra feet of speaker cable at the speaker end.



Select the wall locations for the Harmony system. Try to create a 60-degree angle horizontally between the speaker pair, relative to the listening position. A spacing of 8 feet between speakers is achievable in rooms 12 to 15 feet in width. (Figure 1) Spacing may be affected by the use of a video monitor or screen. To facilitate installation, Legacy has designed the Harmony Center to be located either above or below a thin profile wall monitor.

Speaker Installation

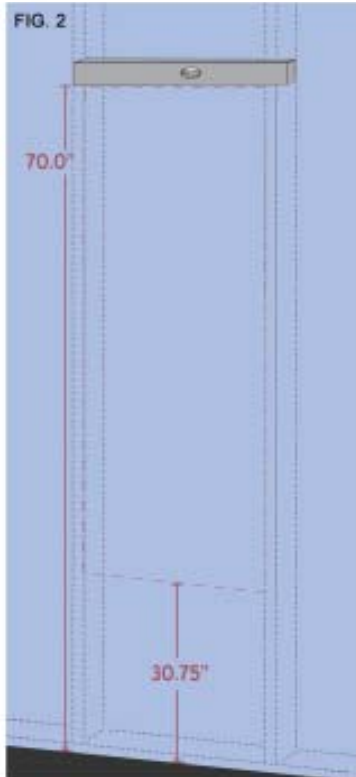

Cut Opening

2. Locate the mounting area between two studs.
3. Using a level, scribe two 14.5" horizontal guide lines onto wall surface. The upper line should be 70" off the floor. The lower line is 30.75" off the floor. (Figure 2)

Speaker Installation

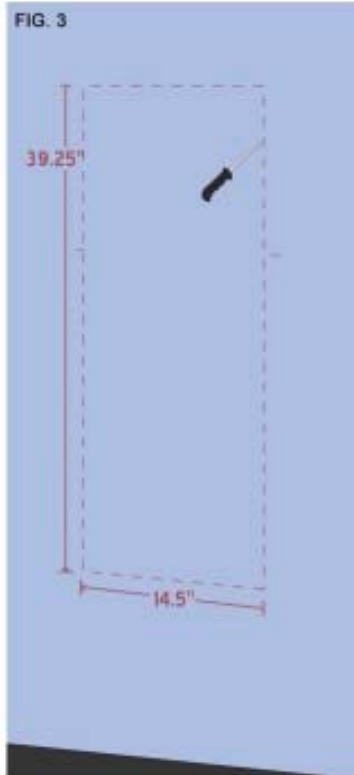

4. Using a drywall saw, cut out the wall opening for the Harmony speaker. The inward facing edges of the studs will serve as vertical guides for the saw. When cut properly, an opening approximately 39.25" x 14.5" will result. (Figure 3)

WARNING: Wear eye protection when cutting drywall. Also be certain there are no electrical, water, or gas lines inside the wall location you are cutting.

Speaker Installation

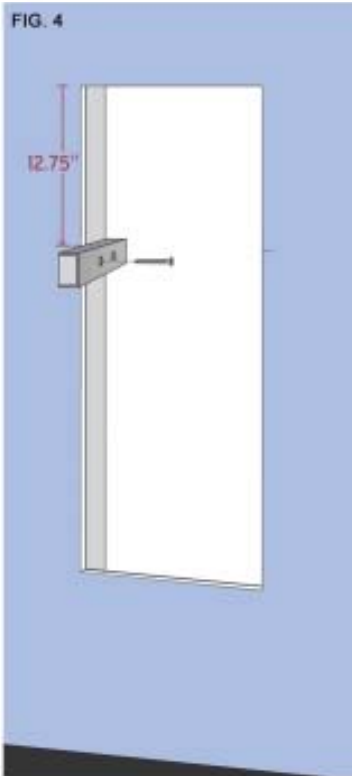

Mount Isolating Support Blocks

5. Position the first of two support blocks as shown. (Figure 4)
 - a) With a pencil, scribe a horizontal line onto the stud at a distance 12.75" down from the top.
 - b) Hold the top of the block even with the scribed line.
 - c) Slide the block until it protrudes 0.75" beyond the outer wall.
 - d) Insert one screw through block and into stud.
 - e) Level block.
 - f) Insert second screw through block and into stud.
6. Using level, transfer another mark representing top of block to opposite stud. (Figure 5)
7. Install second block. (Figure 6)
8. Check both blocks with level. (Figure 7)

Speaker Installation

FIG. 5

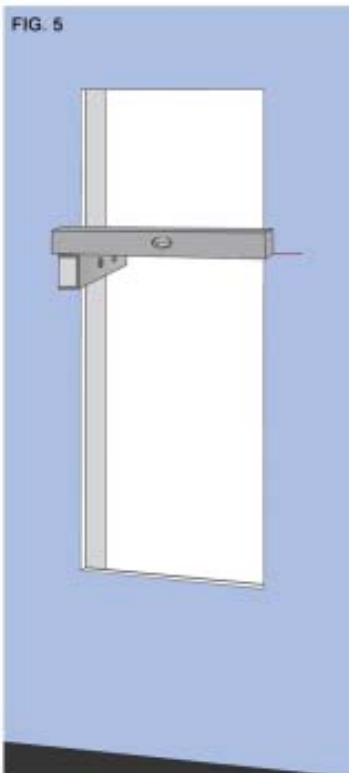

FIG. 6

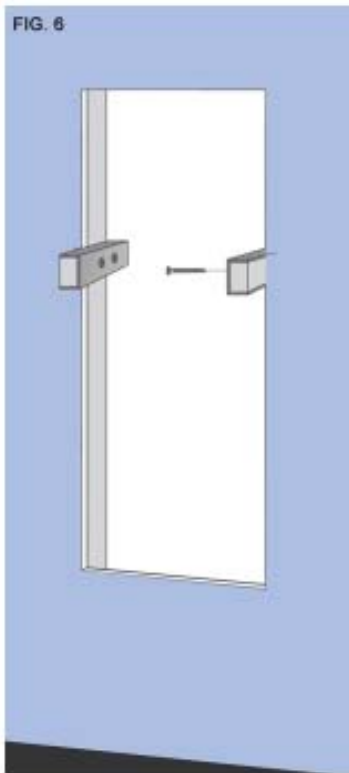
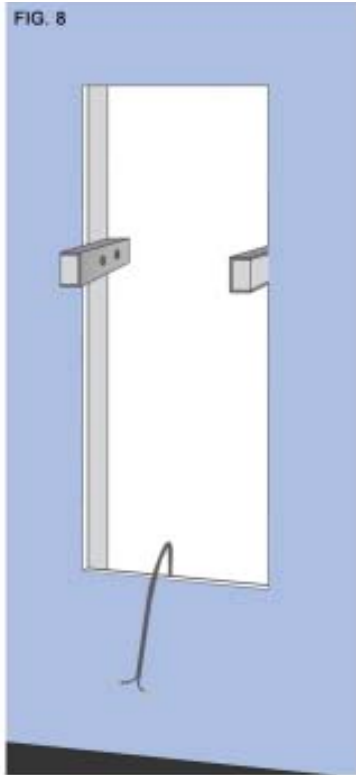

FIG. 7



Speaker Installation

FIG. 8



Connection

9. Prepare wire. Select 10-to-14 gauge cable that complies with applicable code.

a) Strip and terminate speaker cable with spade lugs, banana plugs or twisted bare wire. (Figure 8)

b) Connect each Harmony to the appropriate +, - output terminals of your amplifier or receiver. Harmony should not be connected in parallel with another speaker to same amplifier channel.

Speaker Installation

10. With Harmony cabinet setting on floor, or elevated onto a soft chair, connect positive and negative speaker wire leads to corresponding red and black terminals on bottom of cabinet.

11. Select “High Current Amp” or “Receiver” switch position. Harmony features a unique bass turbo circuit that is applicable with higher current amplifiers. To verify the current capability of your amplifier, make sure the amplifier's 4 ohm rating is 1.5 to 2.0 times the power output at 8 ohms. (Figure 9)

FIG. 9



Example: Amplifier Rating		
8 ohms	4 ohms	Switch Setting
150w	225w	High current
150w	175w	Low current

Speaker Installation

FIG. 10

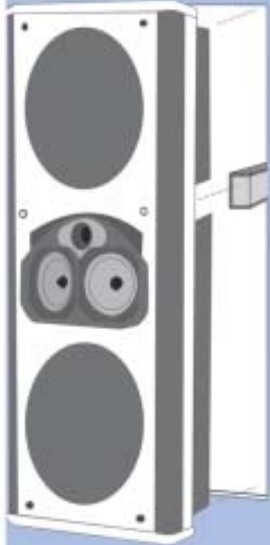

12. With assistance, slide a Harmony speaker cabinet onto isolating support blocks as shown. (Figure 10)

13. Install provided tensioning screws through isolation grommet as shown. (Note: Though the screw couples directly into the end of the support block, the internal steel plate isolation grommet prevent direct mechanical coupling.) (Figure 11)

14. Install plastic grill cups, tapping flush with rubber mallet or with covered block and hammer. (Figure 12)

15. Installation is now complete. Turn on your favorite DVD or Music sit down and enjoy. Should you have further questions, please consult your local dealer, or call 800 283 4644.

Speaker Installation

FIG. 11

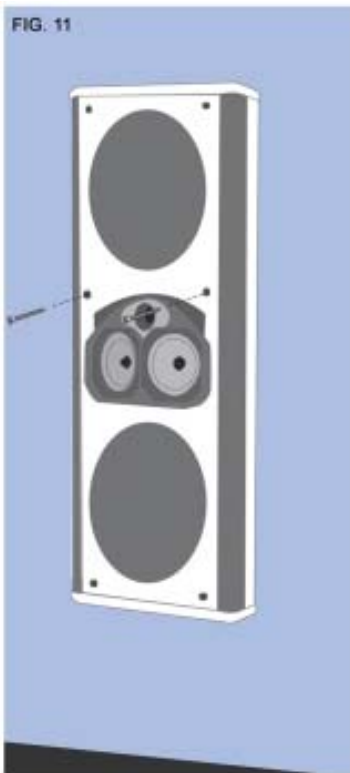
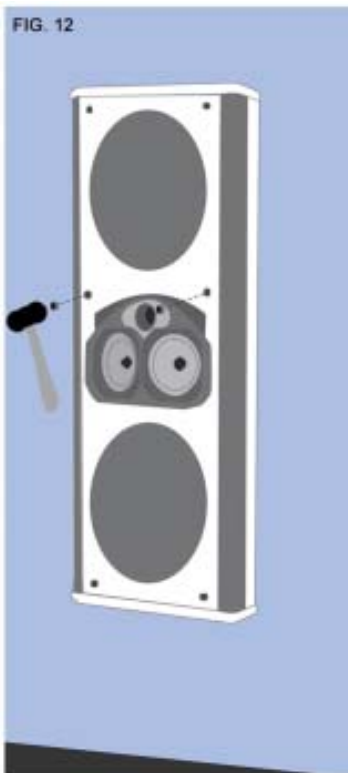

FIG. 12



Hook Up Cables

Before you purchase loudspeaker wire, check local building codes to make sure that the wire is rated to comply with applicable local safety codes such as UL or CL-2. Use only stranded wire no thinner than AWG 16. For runs longer than 100 feet, we recommend minimum of AWG 14. When pulling wire, take care not to pull the wire too fast to prevent stretching the wire or scorching the insulation from friction. Leave 2 to 3 feet of excess loudspeaker wire at both ends; it is easier to trim off excess wire than to splice additional wire. When securing the wire inside the walls, be careful not to pierce the insulation with nails or staples.

Hook Up Cables

The ideal conductor would have negligible resistance, inductance and capacitance. The table below shows how a few actual speaker cables measure up.



Cable	Ω s/ft	pF/ft	μ H/ft
12 ga.	0.0033	24	0.21
14 ga.	0.0048	17	0.13
16 ga.	0.0079	16	0.18
18 ga.	0.0128	28	0.21

Capacitance is considered insignificant in each cable because its effect is well out of the audio bandwidth; inductance can be decreased (at the expense of increased capacitance) by keeping the conductor pair closely spaced.

How long would a cable have to be before inductance effects would impinge on the audio spectrum? Approximately 300 feet of 12 gauge would be required to establish a corner frequency of 20 kHz with an 8 Ohm loudspeaker. As you see, inductance is not a problem for most of us.

Hook Up Cables

What about phase shift due to frequency dependent travel times down the speaker cable? Measurements show that 100 Hz waves will be delayed about 20 billionths of a second behind 10 kHz waves when traveling to the end of a 10 foot speaker cable. Since the cilia of the ear requires 25,000 times longer than this just to transmit phase information, phase shifting is obviously not the primary concern when considering speaker cables.

What about resistance? Finally we are getting somewhere. Resistance is the controlling factor of the amplifier/loudspeaker interface. Excessive resistance can cause major shifts of speaker crossover frequencies. The lower the impedance of the loudspeaker, the greater the effects of series resistance. A 20 foot run of 18 gauge cable can cause up to 10% deviations of crossover center frequencies. That same 20 feet can un-damp your damping factor and reduce your systems' output by one-half decibel.

In summary, there are no perfect cables. The best way to approximate the ideal would be to keep loudspeaker leads as short as is practical.

Amplification

Ideally the loudspeaker would be among the first components selected when assembling a playback system. This would allow the user to choose an amplifier capable of delivering adequate amounts of current into the frequency dependent load presented by the loudspeaker. However, when upgrading a system, audiophiles may find themselves matching their new loudspeakers to their existing amplification. For this reason, extensive measures have been taken to ensure that each Legacy speaker system represents a smooth, non-reactive load to virtually any amplifier.



Often there is much confusion regarding amplification and loudness levels. It should be understood that the role of the amplifier goes beyond that of driving loudspeakers to a given sound pressure level. The amplifier should be able to CONTROL the loudspeakers across the entire music spectrum. This means that parameters such as damping factor (values greater than 60 are acceptable) and dynamic headroom should not be overlooked when comparing amplifiers.

Amplification

How much power will your new speakers need? That ultimately depends on your listening environment and musical tastes. As little as five watts per channel should drive them to a level satisfactory for background music. A typical 45 watt per channel receiver may fill a room with the compressed mid-band energy of “heavy metal,” but seem to lack weight or control with classical recordings. Some audiophiles feel that 200 watts per channel is the bare minimum to avoid audible clipping distortion when reproducing music at “live” playback levels. Your Legacy speakers are designed to take advantage of “high-powered” amplifiers, so don’t be afraid to put them through their paces.

How much is too much power? Rarely is a drive unit damaged by large doses of music power. More often than not the villain is amplifier clipping distortion. Even through decades of refinement, loudspeakers are still notoriously inefficient transducers, requiring huge amounts of power to recreate the impact of the live performance. Typically less than 1% of electrical power is converted into acoustic output. (For example, an omnidirectional transducer with an anechoic sensitivity of 90 dB @ 1w/1m has a full space efficiency of only 0.63%)

Amplification

When an amplifier is unable to fulfill your loudspeakers demands, a damaging harmonic spike may be leaked to the high frequency drivers.

Another important point regarding loudness is that the dB scale is a logarithmic one. This means that a 150 Watt amplifier will potentially sound only twice as loud as a 15 Watt amplifier. If all of this discussion of power and loudness seems a bit abstract, consider the example below.



The average acoustical power developed by a person speaking in a conversational tone corresponds to a mere 0.00001 Watts. The power that would be developed by the entire population of the city of New York speaking at once would barely illuminate a single 100 Watt light bulb.

Designer's Note (From Bill Dudleyston)



Harmony In-Walls were developed using the finest loudspeaker and crossover components available. Countless hours of computer modeling were spent to insure accurate audio reproduction in a variety of installations where placement compromises must sometimes be made. The Harmony In-Wall Loudspeakers deliver the high-fidelity audio reproduction you have come to expect from high-end loudspeakers in a cabinet.

Specifications

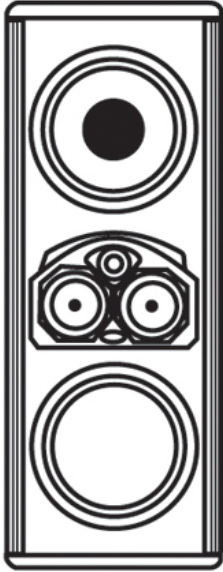

System Type: 4 drivers, 3 way

Tweeter: Silk Dual Diaphragm W/ Quadra-Pole Neodymium Motor

Midwoofer: 2 x5.25" Cast Frame Kevlite-TI

Woofer: 12" Carbon Reinforced Pulp

Low Frequency Alignment: 5th Order Assisted W/ Passive Radiator.

Frequency Response: 38Hz – 25 kHz

Impedance: 4 Ohms

Sensitivity: 91 dB

Recommended Amplification: 15-150 Watts

Crossover Frequency: 250, 3K

Dimensions (H x W x D): 40.75"x16.2"x6"

Weight: 54 pounds

Notes:



© 2003 Legacy Audio
150 Locust Street.
Macungie, PA 18062
Phone: 610 965 0494
Fax: 610 965 4915