

lexicon[®]

MC-4 Digital Controller

User Guide



IMPORTANT SAFETY INSTRUCTIONS

1. Read these instructions.
2. Keep these instructions.
3. Heed all warnings.
4. Follow all instructions.
5. Do not use this apparatus near water.
6. Clean only with a dry cloth.
7. Do not block any ventilation openings. Install in accordance with the manufacturer's instructions.
8. Do not install near any heat sources such as radiators, heat registers, stoves or another apparatus (including amplifiers) that produces heat.
9. Do not defeat the safety purpose of the polarized or grounding-type plug. A polarized plug has two blades with one wider than the other. A grounding-type plug has two blades and a third grounding prong. The wide blade or the third prong are provided for your safety. If the provided plug does not fit into your outlet, consult an electrician for replacement of the obsolete outlet.
10. Protect the power cord from being walked on or pinched particularly at plugs, convenience receptacles and the point where they exit from the apparatus.
11. Only use attachments/accessories specified by the manufacturer.
12. Use only with the cart, stand, tripod, bracket or table specified by the manufacturer or sold with the apparatus. When a cart is used, use caution when



moving the cart/appartus combination to avoid injury from tip-over.

13. Unplug this apparatus during lightning storms or when unused for long periods of time.
 14. Refer all servicing to qualified service personnel. Servicing is required when the apparatus has been damaged in any way, such as when a power supply cord or plug is damaged, liquid has been spilled or objects have fallen into the apparatus, the apparatus has been exposed to rain or moisture, does not operate normally or has been dropped.
- Refer to the manufacturer's operating instructions for power requirements. Be advised that different operating voltages may require the use of different line cord and/or attachment plug.

- Do not install the unit in an unventilated rack or directly above heat-producing equipment such as power amplifiers. Observe the maximum ambient operating temperature listed in the product specification.
- Never attach audio power amplifier outputs directly to any of the unit's connectors.

This equipment has been tested and found to comply with the limits for a Class B digital device, pursuant to Part 15 of FCC Rules. These limits are designed to provide reasonable protection against harmful interference in a residential installation. This equipment generates, uses and radiates radio frequency energy and, if not installed and used in accordance with the instructions, may cause harmful interference to radio or television reception, which can be determined by turning the equipment off and on. The user is encouraged to try to correct the interference by one or more of the following measures:

- Reorient or relocate the receiving antenna.
- Increase the separation between the equipment and the receiver.
- Connect the equipment into an outlet on a circuit different from that to which the receiver is connected.
- Consult the dealer or an experienced radio/television technician for help.

WARNING

To reduce the risk of fire or electric shock, do not expose the apparatus to rain or moisture. Do not place objects containing liquid, such as vases, on this apparatus.

This triangle, which appears on your component, alerts you to the presence of uninsulated, dangerous voltage inside the enclosure - voltage that may be sufficient to constitute a risk of shock.



CAUTION
RISK OF ELECTRIC SHOCK
DO NOT OPEN



This triangle, which appears on your component, alerts you to important operating and maintenance instructions in this accompanying literature.



3 Oak Park
Bedford, MA 01730-1413 USA
Telephone: 781-280-0300
Fax: 781-280-0490
www.harmanpecialtygroup.com

Customer Support

Telephone: 781-280-0300
Sales Fax: 781-280-0495
Service Fax: 781-280-0499

harman specialty group

HSG Part No. 070-16329 | Rev 0 | 10/04

Manufactured under license from Dolby Laboratories. "Dolby," "Pro Logic" and the double-D symbol are trademarks of Dolby Laboratories. "Surround EX" is a jointly developed technology of THX and Dolby Laboratories, Inc. and is a trademark of Dolby. Used under authorization.

THX, Ultra and Ultra2 are trademarks of THX Ltd., which may be registered in some jurisdictions. All rights reserved.

Manufactured under license from Lucasfilm Ltd. U.S. Patent Nos. 5,043,970; 5,189,703; and/or 5,222,059. European Patent No. 0323830. Other U.S. and foreign patents pending. Lucasfilm is a trademark of Lucasfilm Ltd.

"DTS," "DTS-ES," "Neo:6" and "DTS 96/24" are trademarks of Digital Theater Systems, Inc.

SACD is a trademark of Sony Electronics, Inc.

SHARC is a trademark of ANALOG DEVICES, INC.

"Lexicon," "Logic 7" and the L7 logo are registered trademarks of Harman International Industries, Inc. U.S. Patent Nos. D454,553; D454,860; 5,796,844; 5,870,480 and other worldwide patents issued and pending.

© 2004 Harman International Industries, Inc. All rights reserved.

This document should not be construed as a commitment on the part of Harman Specialty Group. The information it contains is subject to change without notice. Harman Specialty Group assumes no responsibility for errors that may appear within this document.

DOCUMENTATION CONVENTIONS

This document contains general safety, installation and operation instructions for the MC-4 Digital Controller. It is important to read this user guide before attempting to use this product. Pay particular attention to safety instructions.

The following symbols are used in this document:



Appears on the component to indicate the presence of uninsulated, dangerous voltage inside the enclosure—voltage that may be sufficient to constitute a risk of shock.



Appears on the component to indicate important operating and maintenance instructions in the accompanying literature.

WARNING

Calls attention to a procedure, practice, condition or the like that, if not correctly performed or adhered to, could result in injury or death.

CAUTION

Calls attention to a procedure, practice, condition or the like that, if not correctly performed or adhered to, could result in damage or destruction to part or all of the product.

Note:

Calls attention to information that is essential to highlight.

SETUP ▶ **INPUTS** ▶ **DVD1** ▶ **NAME** ▶ **EDIT INPUT NAME**

Represents a menu path. The menu items in gray boxes must be selected with the remote control Menu 4 arrow to access the menu or menu item in the black box. For instance, the SETUP, INPUTS and DVD1 menu items must be selected to open the DVD1 INPUT SETUP menu.

The DVD1 INPUT SETUP menu is used here as an example and will continue to be used as an example throughout this document. Whenever it appears, any other INPUT SETUP menu may be substituted. Likewise, whenever the DVD1 input appears as a step in a menu path, any other input may be substituted.

- This document uses the term DTS(-ES) to indicate that DTS-ES encoding may or may not be present in the input source.

Introduction

Documentation Conventions ii

US	Important Safety Instructions	v
DE	Wichtige Sicherheitshinweise	v
ES	Instrucciones de seguridad importantes	vi
FR	Instructions importantes relatives à la sécurité.	vi
IT	Importanti norme di sicurezza.	vii
PT	Instruções importantes de segurança.	vii
DK	Vigtig information om sikkerhed.	viii
FI	Tärkeitä turvallisuusohjeita	viii
NO	Viktig informasjon om sikkerhet.	ix
SE	Viktiga säkerhetsföreskrifter	ix
US	Unpacking and Inspection	x
DE	Auspacken und Überprüfung	x
ES	Desembalaje e inspección	x
FR	Contenu de l’emballage et inspection.	x
IT	Disimballaggio ed ispezione	x
PT	Retirando a embalagem e inspeccionando	x

Section 1: Getting Started

About the MC-4	1-2
<i>Highlights • Product Registration</i>	
Installation Considerations.	1-4
Remote Control Battery Installation	1-5

Section 2: Basic Operation

Front Panel Overview	2-2
Rear Panel Overview	2-4
Remote Control Overview	2-7
<i>Operation Considerations • MAIN MENU • Menu Navigation</i>	
<i>• Menu Item Selection • Command Bank Activation •</i>	
<i>Command Matrix</i>	
Two-Line Status	2-14
STATUS Menus	2-14
<i>2CH STATUS • DOLBY D STATUS • DTS(-ES) STATUS & DTS</i>	
<i>STATUS • 5.1a BYPASS STATUS • 2CH BYPASS STATUS •</i>	
<i>DIGITAL STATUS</i>	
STATUS Menu Parameter Descriptions	2-19
<i>STATUS Menu Level Meters</i>	

Section 3: SETUP

SETUP	3-2
INPUT SETUP	3-3
<i>Changing Input Names (NAME) • Assigning Audio & Video</i>	
<i>Input Connectors • Selecting Preferred Listening Modes •</i>	
<i>Configuring Advanced Settings</i>	
SPEAKER SETUP.	3-24
<i>Custom Speaker Setups • THX Speaker Setups • Measuring</i>	
<i>Speaker Distances • Calibrating Output Levels</i>	































Section 3: SETUP (continued from page iii)

REAR PANEL CONFIG	3-43
DISPLAY SETUP	3-45
<i>On-Screen Display Setup • Front Panel Display Setup</i>	
VOLUME CONTROL SETUP	3-51
TRIGGER SETUP	3-52
LOCK OPTIONS	3-54

Section 4: AUDIO CONTROLS

AUDIO CONTROLS	4-2
----------------------	-----

Section 5: MODE ADJUST

MODE ADJUST	5-2
Listening Mode Activation	5-2
<i>Preferred Listening Mode Selection Parameters • Mode ▲ and ▼ Buttons • Mode Family Selection Buttons</i>	
Listening Mode Descriptions	5-4
 FILM •  TV •  MUSIC •  MUSIC SURR •  PLII + 	
•  PLII MOVIE •  PL II MUSIC •  PRO LOGIC •  PL	
+  •  CIN •  +  •  MUSIC •	
NIGHTCLUB • CONCERT HALL • CHURCH • CATHEDRAL • PANORAMA • 2-CH SURROUND • 2-CHANNEL • MONO LOGIC • MONO SURROUND • MONO • 5.1  FILM • 5.1	
 TV • 5.1  MUSIC •  SurEX •  MUSIC •  DIGI-	
TAL EX • 5.1 2-CHANNEL • 5.1 MONO LOGIC • 5.1 MONO SURR • 5.1 MONO •   FILM •   MUSIC •	
  •   MUSIC •  •  2-CHAN	
• 5.1a BYPASS • 2CH BYPASS	
Listening Mode Menu Option & Parameter Descriptions . . .	5-29

Section 6: Troubleshooting & Maintenance

Troubleshooting	6-2
Routine Maintenance	6-3
Restoring Factory-Default Settings	6-4

Appendix

Specifications	A-2
Declaration of Conformity	A-4
Menu Tree	A-5
Installation Worksheet	A-14

Index

Limited Warranty.	Inside Back Cover
--------------------------------	--------------------------

US

ENGLISH
IMPORTANT SAFETY INSTRUCTIONS

US

1. Save these instructions for later use.
2. Follow all instructions and warnings marked on the component.
3. Always use this component with the correct line voltage. Refer to the manufacturer's operating instructions for power requirements. Be advised that different operating voltages may require the use of different line cords and/or attachment plugs.
4. Do not install this component in an unventilated rack or directly above heat-producing components such as power amplifiers. Observe the maximum ambient operating temperature listed in the component specifications.
5. Slots and openings on the case are provided for ventilation; to ensure reliable operation and prevent the component from overheating, these openings must not be blocked or covered. Never push objects of any kind through any of the ventilation slots. Never spill liquid of any kind on the component.
6. Never attach audio power amplifier output connectors directly to any of this component's connectors.
7. To prevent shock or fire hazard, do not expose this component to rain or moisture, or operate it where it will be exposed to water.
8. Do not attempt to operate this component if it has been dropped, damaged, or exposed to liquids, or if it exhibits a distinct change in performance indicating the need for service.
9. This component should only be opened by qualified service personnel. Removing covers exposes hazardous voltages.



This triangle, which appears on the component, indicates the presence of uninsulated, dangerous voltages inside the enclosure—voltages that may be sufficient to constitute a risk of shock.



This triangle, which appears on the component, indicates important operating and maintenance instructions in this accompanying documentation.

DE

DEUTSCH
WICHTIGE SICHERHEITSHINWEISE

DE

1. Bewahren Sie diese Anleitungen zur späteren Benutzung auf.
2. Befolgen Sie alle Anleitungen und alle Warnhinweise auf dem Gerät.
3. Betreiben Sie das Gerät immer mit der korrekten Netzspannung. Angaben über den Strombedarf entnehmen Sie bitte den Betriebsanweisungen des Herstellers. Bei unterschiedlichen Betriebsspannungen kann die Verwendung anderer Netzkabel und/oder Anschlussstecker erforderlich werden.
4. Bauen Sie das Gerät nie in ein unbelüftetes Rack oder direkt über Wärme erzeugenden Geräten wie Verstärkern ein. Beachten Sie die in der Produktspezifikation aufgeführte maximale Umgebungstemperatur für den Betrieb.
5. Schlitze und Öffnungen in der Box dienen der Belüftung, damit das Gerät zuverlässig läuft und sich nicht überhitzt. Diese Öffnungen dürfen nicht abgedeckt oder blockiert werden. Auch dürfen keine Gegenstände in sie hineingesteckt werden. Verschütten Sie niemals Flüssigkeiten, gleich welcher Art, auf das Gerät.
6. Schließen Sie niemals Stromausgänge des Audioverstärkers direkt an das Gerät an.
7. Zur Vermeidung von elektrischen Schlägen oder Brandgefahr darf das Gerät weder Regen noch Feuchtigkeit ausgesetzt oder an Orten betrieben werden, wo es mit Wasser in Berührung kommen kann.
8. Versuchen Sie nie, das Gerät zu betreiben, wenn es fallen gelassen, beschädigt oder Flüssigkeiten ausgesetzt wurde oder wenn ein deutlicher Leistungsunterschied zu verzeichnen ist, der darauf hinweist, dass es gewartet werden muss.
9. Dieser Apparat sollte nur von qualifizierten Fachleuten geöffnet werden. Das Abnehmen von Abdeckungen setzt Sie gefährlichen Spannungen aus.



Dieses Dreieck, welches auf Ihrem Bauteil angebracht ist, warnt Sie vor dem Vorhandensein nicht isolierter gefährlicher Spannung im Gerät. Diese Spannung kann so hoch sein, dass das Risiko eines Stromschlags besteht.



Dieses Dreieck, welches auf Ihrem Bauteil angebracht ist, macht Sie auf wichtige Betriebs- und Wartungshinweise in diesen Hinweisen aufmerksam.

ES

ESPAÑOL

ES

INSTRUCCIONES DE SEGURIDAD IMPORTANTES

1. Guarde estas instrucciones para futuras referencias.
2. Siga todas las instrucciones y tenga en cuenta las advertencias que aparecen en la unidad y en las instrucciones de funcionamiento.
3. Utilice siempre la tensión de línea correcta. Consulte las instrucciones del fabricante, donde se especifican los requisitos de alimentación. Tenga en cuenta que unas tensiones operativas diferentes pueden precisar de la utilización de diferentes cables de alimentación y/o enchufes.
4. No instale la unidad en un rack sin ventilación, o directamente sobre equipos que generen calor, como amplificadores de potencia. Tenga en cuenta la temperatura operativa ambiental máxima que se detalla en las especificaciones del producto.
5. Las ranuras y aberturas del equipo son para su ventilación—para garantizar un funcionamiento fiable y evitar que la unidad se sobrecaliente, no bloquee, cubra o inserte objetos en las aberturas. No derrame nunca líquidos de ningún tipo sobre la unidad.
6. Nunca conecte directamente salidas de amplificadores de potencia de audio a ninguno de los conectores de la unidad.
7. Para evitar descargas eléctricas o incendios, no exponga la unidad a la humedad o la lluvia, ni la utilice donde pueda estar expuesta al agua.
8. No intente utilizar la unidad si ésta ha caído, se ha dañado, ha estado expuesta a líquidos, o si muestra un cambio importante en sus prestaciones, lo cual indicaría la necesidad de una reparación.
9. Esta unidad deberá ser abierta únicamente por personal calificado. Si usted quita las coberturas se expondrá a voltajes peligrosos.



Este triángulo, que aparece en su componente, alerta de la presencia de una tensión peligrosa no aislada en el interior del equipo—una tensión que puede ser suficiente como para constituir un riesgo de descarga eléctrica.



Este triángulo, que aparece en su equipo, le alerta de instrucciones operativas y de mantenimiento importantes en los documentos que acompañan el producto.

FR

FRANÇAIS

FR

INSTRUCTIONS IMPORTANTES RELATIVES
À LA SÉCURITÉ

1. Conservez ces instructions pour pouvoir vous y référer ultérieurement.
2. Suivez toutes ces instructions et tenez compte de tous les avertissements indiqués sur l'appareil et dans la documentation fournie avec l'appareil.
3. Utilisez toujours la tension secteur correcte. Consultez les instructions du fabricant précisant les caractéristiques d'alimentation à respecter. Attention, le type de cordon secteur et/ou de prise secteur peut varier selon des tensions en vigueur dans l'installation.
4. N'installez pas l'appareil dans un Rack mal ventilé ou directement au-dessus d'un appareil dégageant de la chaleur comme un amplificateur de puissance. Respectez la température maximale de fonctionnement précisée dans les caractéristiques techniques.
5. Les ouvertures dans le boîtier assurent la bonne ventilation de l'appareil, évitent toute surchauffe et assurent le bon fonctionnement du système. Veillez à ne pas obstruer, couvrir ou insérer d'objets dans ces ouvertures. Veillez à ne pas renverser de liquide sur l'appareil.
6. Ne reliez jamais directement les sorties audio des amplificateurs de puissance aux connecteurs de l'appareil.
7. Afin d'éviter tout risque d'électrocution ou d'incendie, n'exposez pas l'appareil à la pluie ou à l'humidité; ne l'utilisez pas dans des endroits exposés aux projections de liquides.
8. N'essayez pas d'utiliser l'appareil si celui-ci est tombé, a été endommagé, exposé à des projections de liquides ou si vous constatez des dysfonctionnements nécessitant l'intervention d'un technicien spécialisé.
9. Cet appareil ne doit être ouvert que par un personnel de service qualifié. En enlevant les couvercles vous vous exposez à des tensions électriques dangereuses.



Le symbole de la foudre dans un triangle sert à alerter l'utilisateur sur la présence d'intérieur de l'appareil de tensions non isolées susceptibles de constituer un risque d'électrocution.



Le point d'exclamation dans un triangle sert à alerter l'utilisateur sur la présence de nombreuses instructions de maintenance dans le manuel fourni avec l'appareil.

IT

ITALIANO

IMPORTANTI NORME DI SICUREZZA

IT

1. Conservare le presenti norme per l'utilizzo futuro.
2. Seguire sempre tutte le istruzioni e gli avvertimenti segnati sull'unità e nelle istruzioni operative.
3. Utilizzare sempre la corretta tensione di alimentazione. Fare riferimento al manuale del costruttore per le caratteristiche di alimentazione. Tensioni di rete diverse necessitano anche di un diverso cavo con spine differenti.
4. Non installare l'unità in un rack poco ventilato, o direttamente sopra apparecchiature che producono calore, come amplificatori di potenza. Controllare la massima temperatura ambientale di esercizio sulle specifiche tecniche del prodotto.
5. Fori ed aperture nei pannelli sono necessari per garantire un corretta ventilazione e prevenire surriscaldamenti. Queste aperture non devono essere coperte o ostruite. Non inserire oggetti di alcun tipo nei fori di ventilazione. Evitare il contatto con liquidi di qualsiasi genere.
6. Evitare di collegare le uscite di un amplificatore di potenza direttamente a qualsiasi connettore dell'unità.
7. Per evitare il rischio di scosse elettriche non esporre il prodotto a pioggia o umidità. Evitare l'uso dove possa essere esposto all'acqua.
8. Non tentare di utilizzare il prodotto se è caduto, se è stato a contatto con liquidi, o mostra chiari segni di danneggiamento o cambio di prestazioni che indicano la necessità di assistenza tecnica.
9. Ogni intervento sull'unità va eseguito esclusivamente da personale qualificato. La rimozione della copertura comporta l'esposizione al pericolo di folgorazione.



Il presente triangolo impresso sul componente avverte la presenza di tensioni pericolose non isolate all'interno della copertura—tali tensioni rappresentano un pericolo di folgorazione.



Il presente triangolo impresso sul componente avverte l'utente della presenza nella documentazione allegata di importanti istruzioni relative al funzionamento ed alla manutenzione.

PT

PORTUGUESE

INSTRUÇÕES IMPORTANTES DE SEGURANÇA

PT

1. Guarde essas instruções para uso posterior.
2. Siga todas as instruções e fique atento aos avisos marcados na unidade e nas instruções de operação.
3. Sempre use com a voltagem correta. Veja no manual de instruções do fabricante qual a alimentação necessária. Lembre-se que voltagens de operação diferentes podem precisar de um cabo ou plug diferentes.
4. Não instale a unidade em um suporte sem ventilação ou diretamente acima de equipamentos que produzam calor, como transformadores. Observe a temperatura ambiente máxima de operação indicada na especificação do produto.
5. O revestimento da unidade é provido de fendas e aberturas para ventilação—para assegurar uma operação confiável e evitar que a unidade se superaqueça. Não bloqueie, cubra ou insira objetos nas aberturas. Nunca derrube líquido de qualquer espécie na unidade.
6. Nunca ligue saídas de amplificadores de áudio diretamente a qualquer dos conectores da unidade.
7. Para evitar danos de choque ou fogo, não exponha a unidade à chuva ou umidade, ou opere-a onde haja exposição à água.
8. Não tente operar a unidade se ela for derrubada, danificada, exposta à líquidos ou apresente uma mudança de performance notável, indicando a necessidade de manutenção.
9. Esta unidade só deveria ser aberta através de pessoal de serviço qualificado. Removendo coberturas o exporão a voltagens perigosas.



Esse triângulo que aparece no seu console, alerta para a presença de voltagem perigosa e não isolada no recinto—voltagem que pode ser suficiente para constituir um risco de choque.



Esse triângulo que aparece no seu console alerta para instruções importantes de operação e manutenção neste manual.



DANSK



VIGTIG INFORMATION OM SIKKERHED

1. Gem denne vejledning til senere brug.
2. Følg alle anvisninger og advarsler på apparatet.
3. Apparatet skal altid tilsluttes den korrekte spænding. Der henvises til brugsanvisningen, der indeholder specifikationer for strømforsyning. Der gøres opmærksom på, at ved varierende driftsspændinger kan det blive nødvendigt at bruge andre lednings- og/eller stiktyper.
4. Apparatet må ikke monteres i et kabinet uden ventilation eller lige over andet udstyr, der udvikler varme, f.eks. forstærkere. Den maksimale omgivelsestemperatur ved drift, der står opført i specifikationerne, skal overholdes.
5. Der er ventilationsåbninger i kabinettet. For at sikre apparatets drift og hindre overophedning må disse åbninger ikke blokeres eller tildækkes. Stik aldrig noget ind igennem ventilationsåbningerne, og pas på aldrig at spilde nogen form for væske på apparatet.
6. Udgangsstik fra audioforstærkere må aldrig sættes direkte i apparatet.
7. Apparatet må ikke udsættes for regn eller fugt og må ikke bruges i nærheden af vand for at undgå risiko for elektrisk stød og brand.
8. Apparatet må aldrig bruges, hvis det er blevet stødt, beskadiget eller vådt, eller hvis ændringer i ydelsen tyder på, at det trænger til eftersyn.
9. Dette apparat må kun åbnes af fagfolk. Hvis dækslet tages af, udsættes man for livsfarlig højspænding.



Denne mærkat på komponenten advarer om uisoleret, farlig spænding i apparatet—høj nok til at give elektrisk stød.



Denne mærkat på komponenten advarer om vigtig driftsog vedligeholdelsesinformation i den tilhørende litteratur.



SUOMI



TÄRKEITÄ TURVALLISUUSOHJEITA

1. Säilytä nämä ohjeet tulevaa käyttöä varten.
2. Seuraa kaikkia yksikköön merkittyjä ohjeita ja varoituksia.
3. Käytä aina oikeaa verkkojännitettä. Tehovaatimukset selviävät valmistajan käyttöohjeista. Huomaa, että eri käyttöjännitteet saattavat vaatia toisenlaisen verkkojohdon ja/tai pistokkeen käytön.
4. Älä asenna yksikköä telineeseen jossa ei ole tuuletusta, tai välittömästi lämpöä tuottavien laitteiden, esim. tehovahvistimien, yläpuolelle. Ympäristön lämpötila käytössä ei saa ylittää tuotespesifikaation maksimilämpötilaa.
5. Kotelo on varustettu tuuletusreillä ja -aukoilla. Luotettavan toiminnan varmistamiseksi ja ylläpitämisen välttämiseksi näitä aukkoja ei saa sulkea tai peittää. Mitään esineitä ei saa työntää tuuletusaukoihin. Mitään nesteitä ei saa kaataa yksikköön.
6. Älä kytke audiotehovahvistimen lähtöjä suoraan mihinkään yksikön liittimeen.
7. Sähköiskun ja palovaaran välttämiseksi yksikkö ei saa olla sateessa tai kosteassa, eikä sitä saa käyttää märässä ympäristössä.
8. Älä käytä yksikköä jos se on pudonnut, vaurioitunut, kostunut, tai jos sen suorituskyky on huomattavasti muuttunut, mikä vaatii huoltoa.
9. Yksikön saa avata vain laitteeseen perehtynyt huoltohenkilö. Kansien poisto altistaa sinut vaarallisille jännitteille.



Tämä kolmio, joka esiintyy komponentissasi, varoittaa sinua eristämättömän vaarallisen jännitteen esiintymisestä yksikön sisällä. Tämä jännite saattaa olla riittävän korkea aiheuttamaan sähköiskuvaaran.



Tämä kolmio, joka esiintyy komponentissasi, kertoo sinulle, että tässä tuotedokumentoinnissa esiintyy tärkeitä käyttö- ja ylläpito-ohjeita.

NO

NORSK

NO

VIKTIG INFORMASJON OM SIKKERHET

1. Ta vare på denne veiledningen for senere bruk.
2. Følg alle anvisningene og advarslene som er angitt på apparatet.
3. Apparatet skal alltid anvendes med korrekt spenning. Produktbeskrivelsen inneholder spesifikasjoner for strømkrav. Vær oppmerksom på at det ved ulike driftsspenninger kan være nødvendig å bruke en annen ledning-og/eller støpseltype.
4. Apparatet skal ikke monteres i skap uten ventilasjon, eller direkte over var epoduserende utstyr, som for eksempel kraftforstærkere. Den maksimale romtemperaturen som står oppgitt i produktbeskrivelsen, skal overholdes.
5. Apparatet er utstyrt med ventilasjonsåpninger. For at apparatet skal være pålitelig i bruk og ikke veropphetes, må disse åpningene ikke blokkeres eller tildekkes. Stikk aldri noe inn i ventilasjonsåpningene, og pass på at det aldri søles noen form for væske på apparatet.
6. Utgangsplugg fra audioforstærkere skal aldri koples direkte til apparatet.
7. Unngå brannfare og elektrisk støt ved å sørge for at apparatet ikke utsettes for regn eller fuktighet og ikke anvendes i nærheten av vann.
8. Apparatet skal ikke brukes hvis det har blitt utsatt for støt, er skadet eller blitt vått, eller hvis endringer i ytelsen tyder på at det trenger service.
9. Dette apparatet skal kun åpnes av fagfolk. Hvis dekselet fjernes, utsettes man for livsfarlig høyspenning.



Komponenten er merket med denne trekanten, som er en advarsel om at det finnes uisolert, farlig spenning inne i kabinettet—høy nok til å utgjøre en fare for elektrisk støt.



Komponenten er merket med denne trekanten, som betyr at den tilhørende litteraturen inneholder viktige opplysninger om drift og ved.

SE

SVENSKA

SE

VIKTIGA SÄKERHETSFORESKRIFTER

1. Spara dessa föreskrifter för framtida bruk.
2. Följ alla anvisningar och varningar som anges på enheten.
3. Använd alltid rätt nätspänning. Se tillverkarens bruksanvisningar för information om effektkrav. Märkväl, att andra matningsspänningar eventuellt kräver att en annan typs nätsladd och/eller kontakt används.
4. Installera inte enheten i ett oventilerat stativ, eller direkt ovanför utrustningar som avger värme, t ex effektförstärkare. Se till att omgivningens temperatur vid drift inte överskrider det angivna värdet i produktspecifikationen.
5. Behållaren är försedd med hål och öppningar för ventilering. För att garantera tillförlitlig funktion och förhindra överhettning får dessa öppningar inte blockeras eller täckas. Inga föremål får skuffas in genom ventilationshålen. Inga vätskor får spillas på enheten.
6. Anslut aldrig audioeffektförstärkarutgångar direkt till någon av enhetens kontakter.
7. För att undvika elstöt eller brandfara får enheten inte utsättas för regn eller fukt, eller användas på ställen där den blir våt.
8. Använd inte enheten om den har fallit i golvet, skadats, blivit våt, eller om dess prestanda förändrats märkbart, vilket kräver service.
9. Enheten får öppnas endast av behörig servicepersonal. Farliga spänningar blir tillgängliga när locken tas bort.



Denna triangel, som visas på din komponent, varnar dig om en oisolerad farlig spänning inne i enheten. Denna spänning är eventuellt så hög att fara för elstöt föreligger.



Denna triangel, som visas på din komponent, anger att viktiga bruksanvisningar och serviceanvisningar ingår i dokumentationen i fråga.

US *Unpacking and Inspection*

After unpacking the unit, save all packing materials in case the unit ever needs to be shipped. Thoroughly inspect the modules and packing materials for signs of damage. Report any damage to the carrier at once; report equipment malfunction to the dealer.

DE *Auspacken und Überprüfung*

Bewahren Sie nach dem Auspacken des Geräts das Verpackungsmaterial für den Fall auf, dass Sie das Gerät wieder versenden müssen. Überprüfen Sie die Module und die Verpackung sorgfältig auf Anzeichen von Beschädigung. Etwaige Schäden sind dem Transporteur unverzüglich anzuzeigen; Funktionsstörungen sind dem zuständigen Händler zu melden.

ES *Desembalaje e inspección*

Después de desembalar la unidad, guarde todos los materiales de embalaje por si alguna vez transportar la unidad. Inspeccione con atención los módulos y los materiales de embalaje para comprobar que no muestren desperfectos. Informe inmediatamente de cualquier desperfecto al transportista; informe de cualquier problema de funcionamiento del equipo a su distribuidor.

FR *Contenu de l'emballage et inspection*

Après avoir ouvert l'emballage, conservez-le pour tout retour. Inspectez avec soin les modules et les matériaux d'emballage pour tout signe de dommage. Veuillez rapporter immédiatement les dommages auprès du transporteur. Les dysfonctionnements du matériel doivent être signalés à votre revendeur.

IT *Disimballaggio ed ispezione*

Dopo aver disimballato l'unità, salvi tutto il materiale d'imballaggio, in caso Lei abbia bisogno di spedire l'unità. Ispezioni attentamente i moduli ed il materiale d'imballaggio per vedere se riportano segni di danno. Riporti subito ogni segno di danno al corriere; riferisca il malfunzionamento dell'attrezzatura al suo rivenditore.

PT *Retirando a embalagem e Inspeccionando*

Depois de desembalar a unidade, guarde a embalagem caso precise enviar a unidade para manutenção. Inspeccione cuidadosamente o módulo e a embalagem procurando sinais de dano. Avise à loja qualquer tipo de dano ou mal funcionamento do equipamento.

Getting Started

About the MC-4	1-2
<i>Highlights • Product Registration</i>	
Installation Considerations	1-4
<i>Do • Do Not</i>	
Remote Control Battery Installation	1-5

ABOUT THE MC-4

Thank you for purchasing the MC-4 Digital Controller, a 8-channel audio and video control center. The MC-4 includes 8 configurable inputs, each of which can be assigned to its 8 digital audio, 8 analog audio, 5 composite video, 5 S-video or 3 component video input connectors. The analog connectors can be configured for up to two 5.1-channel sources.

Inside and out, the MC-4 is designed for possible future developments. The rear panel includes two RS-232 connectors—one capable of performing configuration downloads and Flash memory software upgrades and the other capable of supporting future developments.

More than just an audio and video control center, the MC-4 offers the latest version of Lexicon's critically acclaimed Logic 7® decoding, which creates a 7.1-channel output signal from stereo, 5.1- and 6.1-channel sources. Unlike other decoders, Logic 7 decoding is compatible with all input sources and requires no special encoding. Because the improvement it provides is clearly audible, Logic 7 is widely regarded as the finest available.

In addition to Logic 7, the MC-4 offers Dolby Digital Surround EX™, Dolby Pro Logic® II, Dolby Pro Logic, DTS® 96/24, DTS Neo:6®, DTS-ES®, THX Ultra2™ and THX® Surround EX decoding. THX Ultra2 certification guarantees that the MC-4 meets the highest THX specifications.

With four floating-point SHARC™ digital signal processing (DSP) engines, the MC-4 boasts enormous processing power. These powerful processors perform custom Lexicon processing such as Logic 7 decoding, bass enhancement, dialog enhancement, auto azimuth, 5-speaker enhancement, bass management, high-precision digital crossovers and audio controls. These features are available at sample rates up to 96kHz, with 24-bit resolution to retain top performance from all sources. In addition, a fifth DSP engine is dedicated to decoding multi-channel compressed audio sources.

The MC-4 is one of the most advanced audio and video control centers available. High-precision 24-bit/96kHz A/D (analog-to-digital) converters can be used to convert stereo analog audio input signals to digital signals, allowing the MC-4 to provide the benefits of precise digital signal processing without sacrificing signal integrity. Alternatively, stereo analog signals can bypass A/D conversion and internal processing, following a pure signal path directly to the output connectors.

Digital audio input signals are processed through a two-stage phase lock loop for extremely low intrinsic jitter and high jitter rejection. Lexicon's proprietary auto azimuth technology corrects timing and level imbalances in stereo sources, ensuring exceptionally accurate playback of surround-encoded sources.

Complementing its audio performance, the MC-4 features two broadcast-quality video switchers. A wide-bandwidth component video switcher accepts analog component or RGB video signals, while a composite and S-video switcher accepts high-quality NTSC, PAL or SECAM video signals. The component video switcher can pass HDTV (high-definition TV) signals, as well as standard-definition TV signals. Both switchers are designed to pass video signals without alteration or degradation.

HIGHLIGHTS

- 8 channels
 - 8 configurable inputs
 - 4 S/PDIF coaxial and 4 S/PDIF optical (Toslink) digital audio input connectors
 - 24-bit/192kHz D/A (digital-to-analog) converters for all audio channels
 - Up to two 5.1-channel analog audio input connectors
 - Analog bypass option for stereo audio input connectors
 - Auto switching between digital and analog audio input connectors
 - 3 component video input connectors with full HDTV compatibility
 - 5 S-video input connectors
 - 5 composite video input connectors
 - 4 32-bit DSP engines
 - Separate DSP engine for decoding compressed audio sources
 - Broadcast-quality video switching
- Built to professional standards, the MC-4 is designed to serve as the control center in any high-quality home entertainment system. Even the most demanding enthusiast will be impressed with its unique combination of power, performance, flexibility and technological sophistication.
- Logic 7 decoding
 - Dolby Digital Surround EX, Dolby Pro Logic II and Dolby Pro Logic decoding
 - DTS 96/24, DTS-ES (discrete and matrix) and DTS Neo:6 decoding
 - THX Ultra2 and THX Surround EX decoding
 - THX Ultra2 certification
 - Flash memory software upgrade capabilities
 - RS-232 control
 - Rear panel IR input connector
 - Two trigger output connectors
 - Optional 19-inch rack-mount kit

PRODUCT REGISTRATION

Please register the MC-4 Digital Controller within 15 days of purchase. To do so, register online at www.lexicon.com or complete and return the product registration card attached to the back cover of this user guide. The product registration card serves no warranty purposes. Retain the sales receipt as proof of warranty coverage.

INSTALLATION CONSIDERATIONS

The MC-4 requires special care during installation to ensure optimal performance. Pay particular attention to the bulleted items that begin below and to other precautions that appear throughout this user guide.

DO

- Install the MC-4 on a solid, flat, level surface such as a table or shelf. The MC-4 can also be installed in a standard 19-inch equipment rack using the optional rack-mount kit available from authorized Lexicon dealers.
- Select a dry, well-ventilated location out of direct sunlight.

DO NOT

- Expose the MC-4 to high temperatures, humidity, steam, smoke, dampness or excessive dust. Avoid installing the MC-4 near radiators and other heat-producing appliances.
- Install the MC-4 near unshielded TV or FM antennas, cable TV decoders and other RF-emitting devices that might cause interference.

DO NOT *(continued)*

- Place the MC-4 on a thick rug or carpet or cover the MC-4 with a cloth, as this might prevent proper cooling.
- Place the MC-4 on a windowsill or in another location in which it will be exposed to direct sunlight.
- Obstruct the front panel IR receiver window. The remote control must be in line of sight with the IR receiver for proper operation. See "Operation Considerations" on page 2-6 for more information.
- Install the MC-4 on a surface that is unstable or unable to support all four of its feet, **unless** it is installed in an equipment rack.
- Stack the MC-4 directly above heat-producing equipment such as power amplifiers.

CAUTION

Before moving the MC-4, make sure it is powered off with the rear panel power switch. Then make sure the power cord is unplugged from the wall outlet.

REMOTE CONTROL BATTERY INSTALLATION

The remote control requires two AA batteries that should be replaced as needed. Use Alkaline batteries, which last longer without leaking. When the batteries are low on power, the remote control enters a low-voltage condition that prevents it from operating the MC-4. When this occurs, follow the instructions below to replace the batteries. Normal operation will resume when new batteries are installed.

To replace the remote control batteries:

1. Locate the battery compartment on the back of the remote control. Then remove the battery compartment cover as shown in Figure A (bottom-left). To do this, press the tab attached to the cover and pull the cover away from the remote control.
2. Remove old batteries inserted in the compartment (if applicable).
3. Insert two AA batteries in the compartment as shown in Figure B (bottom center). Make sure the batteries are correctly inserted, observing the proper polarity.
4. When new batteries have been installed, close the battery compartment cover as shown in Figure C (bottom-right). To do this, align the cover with the guide on the back of the remote control and press the cover until it snaps into place.
5. Dispose of the old batteries (if applicable).

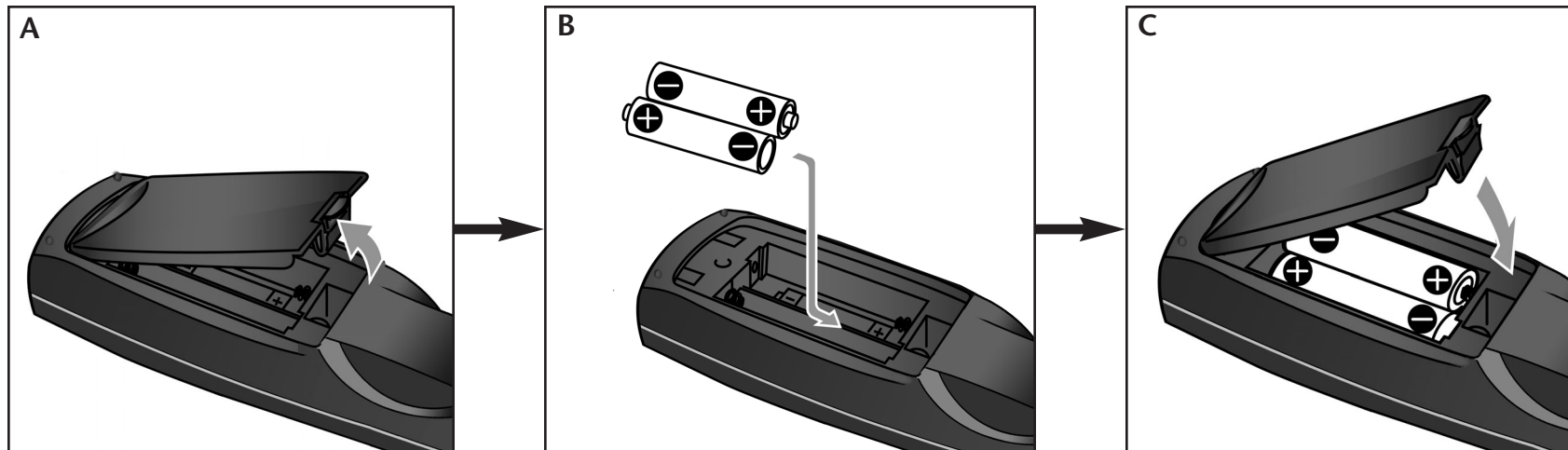

2

Basic Operation

Front Panel Overview	2-2
Rear Panel Overview.	2-4
Remote Control Overview	2-6
<i>Operation Considerations • Menu Navigation • MAIN MENU • Menu Item Selection • Command Bank Activation • Command Matrix</i>	
Two-Line Status	2-14
Status Menus.	2-14
<i>2CH STATUS • DDD STATUS •  STATUS • 5.1a BYPASS STATUS • 2CH BYPASS STATUS • DIGITAL STATUS</i>	
Status Menu Parameter Descriptions	2-18
Status Menu Level Meters.	2-19

FRONT PANEL OVERVIEW

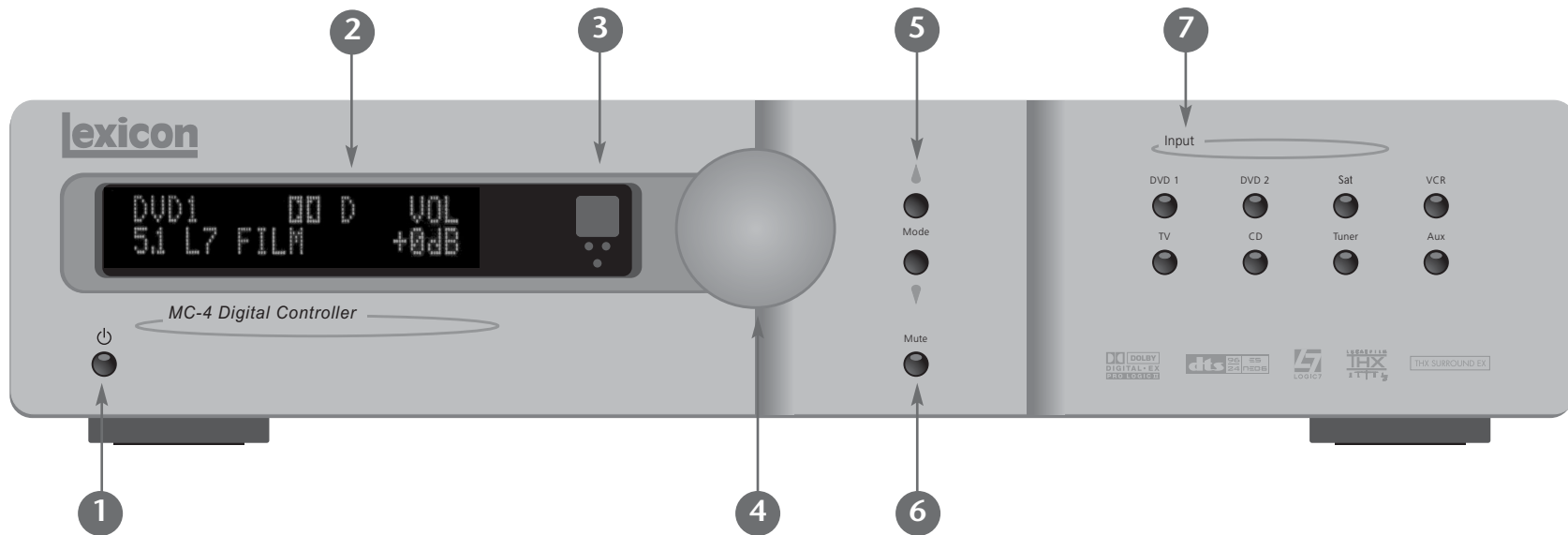

The MC-4 front panel is shown above. The numbers in the front panel illustration correspond to the numbered items that begin below.

1. Standby Button

Activates and deactivates standby mode when the MC-4 is powered on with the rear panel power switch. The standby button performs no function when the MC-4 is powered off with the rear panel power switch.

When standby mode is activated, pressing the standby button deactivates standby mode and activates the MC-4. When standby mode is deactivated, pressing the standby button

activates standby mode and deactivates the MC-4. The red standby button LED lights when standby mode is activated.

2. Front Panel Display

Indicates the current input, listening mode, input source and volume level. This 2 x 20 character display can also be used to view messages and menus, one line at a time. See "Menu Navigation" on page 2-6 for more information.

3. IR Receiver & LEDs

Receives infrared commands from the MC-4 remote control. There are three LEDs located in this area as shown below. The amber LED blinks when a remote control command is received. The red LED lights when the A/D converters are overloading. The blue LED lights when the MC-4 is powered on and activated—even if the FRONT PANEL DISPLAY menu STATUS parameter is ALWAYS OFF.

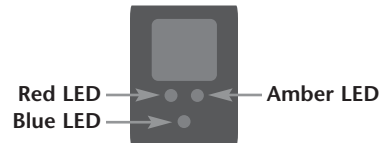

4. Volume Knob

Adjusts volume level. Rotate the volume knob clockwise to increase or counterclockwise to decrease volume level in 1dB increments. The horizontal bar graph shown here appears in the on-screen and front panel displays. This graph illustrates the position at which the current volume level falls within the -80 to +12dB volume range.



Note:

When MC-4 output levels have been properly calibrated, the +0dB volume level setting corresponds to THX reference levels (75dB).

5. Mode ▲ & ▼ Buttons

Scroll to the previous and next available listening mode. Scrolling occurs in the order shown on the MODE ADJUST menu. Pressing the Mode ▲ button scrolls upward through available listening modes and pressing the Mode ▼ button scrolls downward through available listening modes. See "Listening Mode Activation" on page 5-2 for more information.

6. Mute Button

Mutes MC-4 volume level and restores MC-4 volume to its original level. Pressing the mute button the first time lowers volume level. The message MUTE ON displays on the on-screen and front panel displays. Pressing the mute button again restores MC-4 volume to its original level. See "Volume Control Setup" on page 3-51 for information about using the MUTE LEVEL parameter to set mute levels.

The amber mute button LED lights whenever mute is activated, whether activated automatically or manually. For instance, the MC-4 briefly activates mute when changing input sources or listening modes.

7. Input Selection Buttons

Select the MC-4 input. The blue input selection button LEDs light whenever the corresponding input is selected.

REAR PANEL OVERVIEW

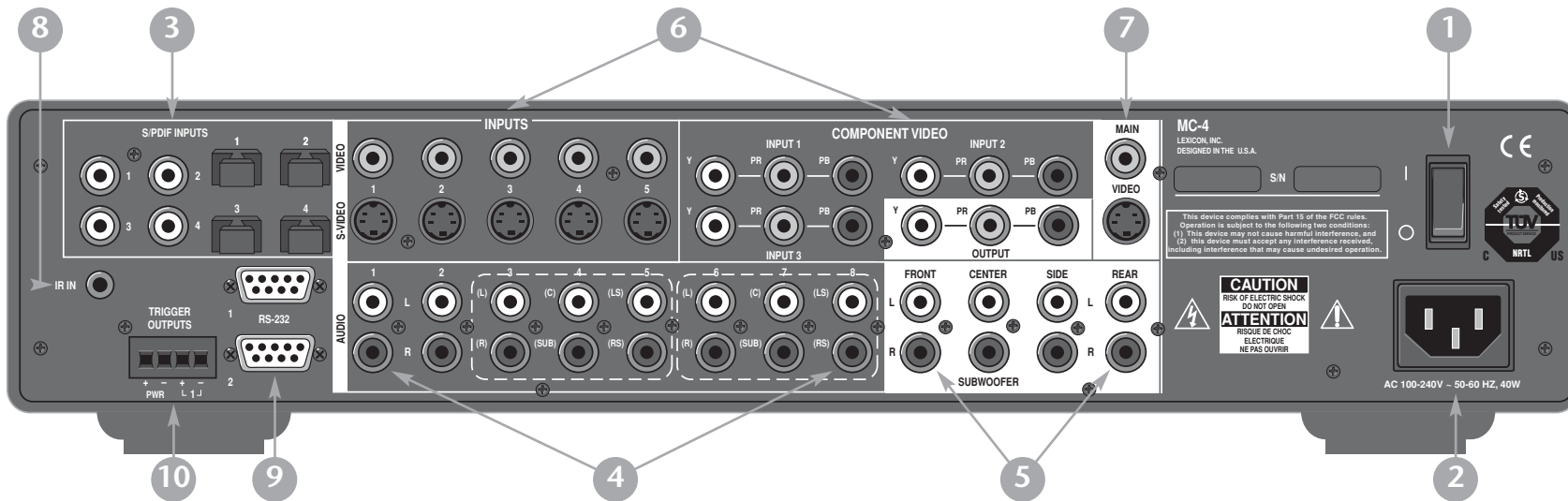

CAUTION Never make or break connections to the MC-4 unless the MC-4 and all associated components are powered off.

The MC-4 front panel is shown above. The numbers in the front panel illustration correspond to the numbered items that begin below.

1. Power Switch

Connects power to the AC input connector and disconnects power from the AC input connector. The **O** represents the off position and the **|** represents the on position. When the MC-4 is powered on, the standby button or remote control **On** button can be used to activate and deactivate standby mode. When the MC-4 is powered off, standby mode is not available.

2. AC Input Connector

Provides power to the MC-4 through the supplied power cord (3 wire, 10 amp, IEC 320).

3. Digital Audio Input Connectors (S/PDIF)

Provide digital audio input. Four S/PDIF coaxial input connectors labeled 1 through 4 and four S/PDIF optical (Toslink) input connectors labeled 1 through 4 are available. These connectors are compatible with PCM (44.1kHz, 48kHz,

88.2kHz and 96kHz), Dolby Digital and DTS(-ES) sources. These connectors are not compatible with MPEG (MP3) sources.

4. Analog Audio Input Connectors

Provide analog audio input. Eight stereo RCA connectors labeled 1 through 8 are available. The connectors labeled 3, 4 and 5 and the connectors labeled 6, 7 and 8 can be configured as 5.1-channel connectors.

When a 5.1-channel analog audio source is present, input signals are sent to the audio output connectors as indicated in the table below.

Input Connector	Output Connector
(L)	Front L
(R)	Front R
(C)	Center
(SUB)	Subwoofer
(LS)	Side L and Rear L
(RS)	Side R and Rear R

5. Audio Output Connectors

Provide analog audio output. Eight RCA connectors labeled Front L/R, Center, Subwoofer, Side L/R and Rear L/R are available.

6. Video Input Connectors

Provide video input. Five composite video connectors labeled Video 1 through 5, five S-video connectors labeled 1 through 5, and three component video connectors labeled INPUT 1 through 3 are available.

7. Video Output Connectors

Provide video output. One composite video connector, one S-video connector and one component video connector are available.

Note:

- Composite video output connectors are available when a composite or S-video source is present.
 - S-video output connectors are available when an S-video source is present.
 - Component video output connectors are available when a component video source is present.
-

8. IR IN Connector

Accepts input of IR signals from infrared distribution equipment. One 3.5mm jack labeled IR IN is available. This connector accepts a stereo plug (Tip/Ring) or mono plug (Tip/Sleeve) connection.

Rear Panel (continued)**9. RS-232 Connectors**

Provide serial control and capabilities for possible future expansion. The RS-232 connector labeled 1 is available for performing configuration downloads and Flash memory software upgrades. The RS-232 connector labeled 2 is available to support possible future expansion.

10. Trigger Output Connectors

Provide 12V DC output to control connected components. Two trigger output connectors are available on a removable terminal block. The connector labeled PWR—the power trigger output connector—is not configurable. It is activated when the MC-4 is activated and deactivated when the MC-4 is deactivated. The trigger output connector labeled 1 can be configured for remote or program operation. See “Trigger Setup” on page 3-52 for more information.

REMOTE CONTROL OVERVIEW

The MC-4 remote control provides full operation of the MC-4, performing commands such as menu navigation that are not available from the front panel. See “Command Matrix” on page 2-9 for more information about the commands remote control buttons perform when each command bank is active.

OPERATION CONSIDERATIONS

The bulleted items that begin below describe factors that can improve or impede remote control operation. Observe these items as well as the remote control battery installation instructions before operating the remote control.

Please note the following before operating the MC-4 remote control:

- The remote control must be in line of sight with the front panel IR receiver. Eliminate obstructions between the remote control and the IR receiver. The remote control may become unreliable if strong sunlight or fluorescent light is shining on the IR receiver.
- For optimal performance, position the remote control at a 30 degree angle no more than 17 feet (5m) from the MC-4. If the MC-4 is placed inside a glass cabinet, tinted glass will reduce the remote control range.
- Remote controllers for different components can interfere with one another. Avoid using remote controls for different components at the same time.
- The remote control batteries should be replaced as needed. See “Remote Control Battery Installation” on page 1-5 for instructions.

MENU NAVIGATION

The remote control Menu arrows must be used to navigate the extensive menu structure shown in the Appendix. The table on the next page indicates the navigation functions remote control Menu arrows perform.

Arrow	Navigation Function(s)
▶	<ul style="list-style-type: none"> When a menu is open, pressing the Menu ▶ arrow selects the highlighted menu item, which opens another menu, opens a parameter drop-down menu or selects the highlighted parameter setting. When no menus are open, pressing the Menu ▶ arrow opens the MAIN MENU.
◀	<ul style="list-style-type: none"> When a menu is open, pressing the Menu ◀ arrow closes the menu and, in most cases, opens the previous menu. Subsequent presses continue to close the current menu and open the previous menu until the MAIN MENU is closed. When the MAIN MENU is closed, the menu structure is also closed. When no menus are open, pressing the Menu ◀ arrow performs no function. When a parameter drop-down menu is open, pressing the Menu ◀ arrow selects the current setting and closes the drop-down menu.
▲▼	<ul style="list-style-type: none"> When a menu is open, pressing the Menu ▲ and ▼ arrows scrolls upward (▲) and downward (▼) through menu items. The highlighted menu item appears on the front panel display. All menu items appear on the on-screen display. A scroll bar appears on the right side of the on-screen display when menu items exceed the on-screen display top and bottom margins. The cursor automatically wraps to the next menu item when the first or last menu item is passed.

MAIN MENU

The MAIN MENU shown to the right represents the beginning of the menu structure. It can be used to open the three main menu branches: MODE ADJUST, AUDIO CONTROLS and SETUP. See sections 3, 4 and 5 for information about these menu branches.

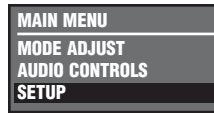

Note:

In certain cases, menu item selection instructions differ. These instances are noted throughout this user guide.

MENU ITEM SELECTION

The remote control Menu arrows must be used to select menu items.

To select a menu item on the open menu:

1. Press the remote control Menu ▲ and ▼ arrows to highlight the desired menu item.
2. Press the Menu ▶ arrow to select the highlighted item. If an option is selected, another menu will open. If a parameter is selected, a parameter drop-down menu will open.

Menu Options

Selecting a menu option opens another menu within the menu structure. For instance, selecting the MAIN MENU SETUP option opens the SETUP menu as shown below.

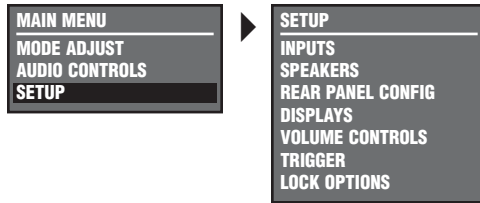

Menu Parameters

Selecting a menu parameter opens a drop-down menu or horizontal bar graph that can be used to select the desired setting.

Parameter Drop-Down Menus

Selecting some menu parameters opens a drop-down menu of available parameter settings. For instance, selecting the DISPLAY SETUP menu CUSTOM NAME parameter opens the drop-down menu shown below, which can be used to select the ON or OFF setting.

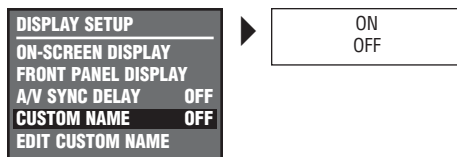

To select the desired setting on a parameter drop-down menu:

1. When the drop-down menu opens, press the remote control Menu \blacktriangle and \blacktriangledown arrows to scroll upward and downward through available settings. The current setting appears beneath the parameter name on the on-screen and front panel displays.
2. Press the Menu \blacktriangleleft arrow to select the current setting and close the drop-down menu.

Horizontal Bar Graphs

Selecting some menu parameters opens a horizontal bar graph, which indicates the position at which the current parameter setting falls within the entire parameter range. The current setting appears at the right of the parameter name in the on-screen and front panel displays.

For instance, selecting the DISPLAY SETUP menu A/V SYNC DELAY parameter opens the horizontal bar graph shown below, which can be used to adjust the amount of audio delay.

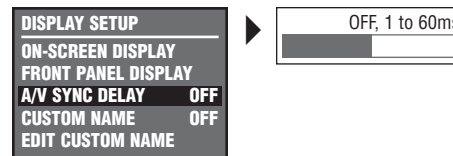

To adjust a parameter setting with a horizontal bar graph:

1. When the horizontal bar graph appears, press the remote control Menu **▲** and **▼** arrows to increase and decrease the setting in the designated increments. The current setting appears to the right of the parameter name on the on-screen and front panel displays.
2. When the desired adjustments have been made, press the Menu **◀** arrow to select the setting and close the horizontal bar graph.

COMMAND BANK ACTIVATION

Remote control buttons perform different commands depending on whether the default, Shift 1 or Shift 2 command bank is activated. For instance, pressing the remote control L7 button selects the Logic 7 listening mode. Pressing the L7 button while the shift 1 command bank is activated selects the Panorama listening mode. Pressing the L7 button while the shift 2 command bank is activated selects the 2-CH Surround listening mode.

The default command bank does not need to be activated; it remains activated unless the Shift 1 or Shift 2 command bank is activated.

- Pressing and holding the remote control **S1 button** activates the shift 1 command bank.
- Pressing and holding the remote control **S2 button** activates the shift 2 command bank.
- The **S1 and S2 buttons** themselves do not send commands to the MC-4. When pressed and held, these buttons activate the associated command bank.

To activate the Shift 1 or Shift 2 command bank:

1. Press and hold the remote control **S1 button** to activate the shift 1 command bank or press and hold the **S2 button** to activate the shift 2 command bank.
2. While holding the selected button, press and release the desired remote control button to send the associated command to the MC-4. See "Command Matrix" on page 2-9 for more information about the commands remote control buttons perform when each command bank is active.
3. Release the **S1** or **S2** button to deactivate the associated command bank.

The ON-SCREEN DISPLAY menu REMOTE STATE parameter controls the remote control command bank indicator. When the REMOTE STATE parameter is ON, a command bank indicator appears in the top-right corner of the on-screen display to indicate the last command bank from which the MC-4 received a command. When the REMOTE STATE parameter is OFF, no command bank indicator appears on the on-screen display.

- A **1** appears when a command from the shift 1 command bank was received last.
- A **2** appears when a command from the shift 2 command bank was received last.
- No character appears when a command from the default command bank was received last.

COMMAND MATRIX

The command matrix that begins on the next page describes the commands remote control buttons perform when each command bank is active.



Button	Default	Shift 1	Shift 2
1	Deactivates standby mode and activates the MC-4.	Reserved for possible future expansion.	Reserved for possible future expansion.
2	Activates standby mode and deactivates the MC-4.	Reserved for possible future expansion.	Reserved for possible future expansion.
3	Toggles the FRONT PANEL DISPLAY menu STATUS parameter between ALWAYS OFF and its current setting.	Centers the AUDIO CONTROLS menu BALANCE and FADER parameters.	Reserved for possible future expansion.
4	Toggles the ON-SCREEN DISPLAY menu BACKGROUND parameter between ON and OFF.	Deactivates the trigger output connector labeled 1 when the connector is configured for remote operation.	Sets the AUDIO CONTROLS menu BASS, TREBLE and TILT EQ parameters to +0.0dB.
5	Toggles the ON-SCREEN DISPLAY menu STATUS parameter between ALWAYS OFF and its current setting.	Activates the trigger output connector labeled 1 when the connector is configured for remote operation.	Reserved for possible future expansion.
6	Displays the two-line status for 2 seconds.	Toggles between opening and closing the STATUS menu for the current input source.	Reserved for possible future expansion.
7	Activates an additional bank of commands that control the MC-4. See "Command Bank Activation" on page 2-9 for more information.		
8	Activates an additional bank of commands that control the MC-4. See "Command Bank Activation" on page 2-9 for more information.		











Button	Default	Shift 1	Shift 2
9	Scroll upward (▲) and downward (▼) through menu items.	Adjust the AUDIO CONTROLS menu FADER parameter forward (▲) and backward (▼).	Increase (▲) and decrease (▼) the output level of the audio output connector labeled Subwoofer (as applied to the activated listening mode).
10	Closes the current menu.	Adjusts the AUDIO CONTROLS menu BALANCE parameter left.	Reserved for possible future expansion.
11	Opens the menu structure and selects the highlighted parameter.	Adjusts the AUDIO CONTROLS menu BALANCE parameter right.	Reserved for possible future expansion.
12	Activates the remote control backlight, making remote control buttons more visible in the dark.		
13	Scrolls to the previous (▲) and next (▼) available listening mode.	Sets volume level to -15dB (▲) or -30dB (▼).	Reserved for possible future expansion.
14	Increases (▲) and decreases (▼) the volume level in 1dB increments.	Increases (▲) and decreases (▼) volume level in 3dB increments.	Reserved for possible future expansion.
15	Toggles between lowering volume level and restoring volume to its original level.	Toggles between fully muting volume level and restoring volume to its original level.	Reserved for possible future expansion.



Button	Default	Shift 1	Shift 2	
16	DVD1	Selects the DVD1 input.	Increases the AUDIO CONTROLS menu BASS parameter in 0.5dB increments.	Reserved for possible future expansion.
	DVD2	Selects the DVD2 input.	Increases the AUDIO CONTROLS menu TREBLE parameter in 0.5dB increments.	Reserved for possible future expansion.
	Sat	Selects the Sat input.	Increases the AUDIO CONTROLS menu TILT EQ parameter in 0.2dB increments.	Reserved for possible future expansion.
	VCR	Selects the VCR input.	Sets the AUDIO CONTROLS menu LOUDNESS parameter to ON.	Reserved for possible future expansion.
	TV	Selects the TV input.	Decreases the AUDIO CONTROLS menu BASS parameter in 0.5dB increments.	Reserved for possible future expansion.
	CD	Selects the CD input.	Decreases the AUDIO CONTROLS menu TREBLE parameter in 0.5dB increments.	Reserved for possible future expansion.
	Tuner	Selects the Tuner input.	Decreases the AUDIO CONTROLS menu TILT EQ parameter in 0.2dB increments.	Reserved for possible future expansion.
	Aux	Selects the Aux input.	Sets the AUDIO CONTROLS menu LOUDNESS parameter to OFF.	Reserved for possible future expansion.



Button	Default	Shift 1	Shift 2	
17 	Selects the Logic 7 film mode family.	Selects the PANORAMA listening mode.	Selects the 2-CH SURROUND listening mode.	
		Selects the Dolby mode family.	See "S1 + DOLBY" (next page) for more information.	Selects the DOLBY PLII MOVIE listening mode.
		Selects the DTS(-ES) mode family.	See "S1 + dts" (next page) for more information.	Selects the DTS NEO:6 CIN listening mode.
		Selects the THX mode family.	See "S1 + THX" (next page) for more information.	Selects the PLII + THX listening mode.
		Selects the Logic 7 music mode family.	Selects the L7 MUSIC SURR listening mode.	Selects the NIGHTCLUB listening mode.
		Selects the Logic 7 TV mode family.	Selects the MONO LOGIC listening mode for 2-channel input sources and the 5.1 MONO LOGIC listening mode for 5.1-channel sources.	Selects the CONCERT HALL listening mode.
18 	Toggles between 7- and 5-channel playback. "See ASA (Advanced Speaker Array)" on page 3-32 for more information.	Adjusts the ADVANCED menu INPUT SELECT parameter, cycling through the ANALOG, DIGITAL, and AUTO settings.	Selects the CHURCH listening mode.	
19 	Toggles between the activated listening mode and the 2-CHANNEL listening mode.	Adjusts the ADVANCED menu 2-CH ANALOG BYP parameter between on and off.	Selects the CATHEDRAL listening mode.	

S1 + DOLBY

- When a 5.1-channel Dolby Digital source is present, pressing and holding the S1 button while pressing and releasing the DOLBY button activates the DOLBY DIGITAL EX or DOLBY DIGITAL listening mode. Subsequent presses adjust the EX DECODING parameter, cycling through the AUTO, ON and OFF settings.

S1 + dts

- When a DTS(-ES) source is present, pressing and holding the S1 button while pressing and releasing the dts button adjusts the ES DECODING parameter, cycling through the AUTO, ON and OFF settings.

S1 + THX

- When a 5.1-channel Dolby Digital source is present, pressing and holding the S1 button while pressing and releasing the THX button activates the 5.1 THX, 5.1 THX SurEX or 5.1 THX Ultra2 listening mode.

TWO-LINE STATUS

The two-line status shown to the right indicates the current input, listening mode, input source and volume level. Pressing the Stat button displays the two-line status for 2 seconds. The two-line status also displays whenever the MC-4 detects a change in status.



The ON-SCREEN DISPLAY menu STATUS parameter controls the length of time for which the two-line status displays in the

on-screen display. The ON-SCREEN DISPLAY menu POSITION parameter controls the position of the two-line status on the on-screen display.

Note:

When the display device is connected to a component video output connector and the ADVANCED menu COMPONENT OSD parameter is set to OFF, the display device does not show the on-screen display, including the two-line status.

STATUS MENUS

Pressing and holding the S1 button while pressing and releasing the Stat button opens the STATUS menu, which provides information about the current input source and listening mode. STATUS menus are available for 2-channel, Dolby Digital, DTS(-ES), 5.1-channel analog and digital sources.

Unlike most other menus, STATUS menus cannot be opened through the selection of menu options. In addition, STATUS menu parameters cannot be adjusted.

To open and navigate the STATUS menu for the current input source:

- Press and hold the remote control **S1 button**.
- While holding the **S1 button**, press the **Stat button**. The first page of the STATUS menu for the current input source will open on the on-screen and front panel displays.

If the STATUS menu includes a second page, the PG1 indicator displays in the top-right corner of the on-screen display. While holding the **S1 button**, press and release the **Stat button** again to open the second page. If the STATUS menu does not include a second page, pressing and releasing the **Stat button** closes the menu. (If this occurs, begin again with step 1.)

- When the desired STATUS menu page is open, release the **S1 button** to deactivate the shift 1 command bank. Then press the remote control **Menu ▲ and ▼ arrows** to scroll upward and downward through STATUS menu parameters available on the current page. When the **S1 button** is held, the **Menu arrows** cannot be used to scroll through STATUS menu parameters.

Note:

STATUS menu parameters provide information about the current input source and listening mode. These parameters cannot be adjusted.

- Press the **Stat button** or the **Menu ◀ arrow** to close the STATUS menu. If the second page of the STATUS menu opens, press the **Stat button** or the **Menu ◀ arrow** again to close the STATUS menu.

STATUS menu descriptions begin in the next column. The table beneath each description lists the default and possible settings for each parameter. See “STATUS Menu Parameter Descriptions” later in this section for detailed information about these parameters.

2CH STATUS

- Provides information about 2-channel input sources.
- Features L and R level meters. See “STATUS Menu Level Meters” on page 2-19 for more information.

Parameter	Possible Settings
INPUT	the selected input
MODE	the activated listening mode
INPUT TYPE	ANLG, PCM
SAMPLE RATE	44.1kHz, 48kHz, 88.2kHz, 96kHz

See “STATUS Menu Parameter Descriptions” on page 2-18 for detailed information about these parameters.

Dolby Digital STATUS

- Provides information about Dolby Digital sources.
- Features L, C, R, SL, SR and SUB level meters. See “STATUS Menu Level Meters” on page 2-19 for more information.

Parameter	Possible Settings
INPUT	the selected input
MODE	the activated listening mode
CHANNELS	3/2.1, 3/2, 3/1, 2/2, 2/1, 2/0, 1/0
BIT RATE	32 to 640kbps
EX ENCODING	MATRIX, NONE
SAMPLE RATE	48kHz
2.0 ENCODING	MATRIX, NONE
DIALOG OFFSET	-27 to +4dB
MIX ROOM	SMALL, LARGE
CENTER MIX LVL	-3.0dB, -4.5dB, -6.0dB
SURR MIX LVL	+0.0dB, -3.0dB, -6.0dB

See “STATUS Menu Parameter Descriptions” on page 2-18 for detailed information about these parameters.

DTS-ES STATUS

- Provides information about DTS(-ES) sources.
- Features L, C, R, SL, SR, SB and SUB level meters. The SB level meter appears when a 6.1-channel input source is present or when a 5.1-channel input source is present and the ES DECODING parameter is set to ON. See “STATUS Menu Level Meters” on page 2-19 for more information.

Parameter	Possible Settings
INPUT	the selected input
MODE	the activated listening mode
CHANNELS	3/3.1, 3/2.1
BIT RATE	754.5 to 1509.7kbps
ES ENCODING	DISCRETE, MATRIX, OFF
WORD LENGTH	16 bits, 20 bits, 24 bits
SAMPLE RATE	44.1kHz, 48kHz, 88.2kHz, 96kHz

See “STATUS Menu Parameter Descriptions” on page 2-18 for detailed information about these parameters.

5.1a BYPASS STATUS

- Provides information about 5.1-channel analog sources.

Parameter	Possible Settings
INPUT	the selected input
MODE	5.1a BYPASS
INPUT TYPE	BYPASS

See "STATUS Menu Parameter Descriptions" on page 2-18 for detailed information about these parameters.

2CH BYPASS STATUS

- Provides information about 2-channel analog sources when the ADVANCED menu 2-CH ANLG BYP parameter is ON.

Parameter	Possible Settings
INPUT	the selected input
MODE	2CH BYPASS
INPUT TYPE	BYPASS

See "STATUS Menu Parameter Descriptions" on page 2-18 for detailed information about these parameters.

DIGITAL STATUS

- Provides information about digital input sources for which a sample rate is detected, but no audio is present in the input signal.

Parameter	Possible Settings
INPUT	the selected input
MODE	the activated listening mode
INPUT TYPE	---
SAMPLE RATE	44.1kHz, 48kHz, 88.2kHz, 96kHz

See "STATUS Menu Parameter Descriptions" on page 2-18 for detailed information about these parameters.

STATUS MENU PARAMETER DESCRIPTIONS**2.0 ENCODING**

MATRIX, NONE

Indicates whether a matrix-encoded source is detected. When the parameter setting is MATRIX, a matrix-encoded source is detected. When the parameter setting is NONE, a matrix-encoded source is not detected. The MC-4 cannot automatically detect matrix encoding in non-flagged sources.

BIT RATE

32kbps to 640kbps or 754kbps to 1509.7kbps

Indicates the rate at which the input signal is encoded. A higher bit rate indicates that less compression was used during the encoding process. Possible settings for Dolby Digital sources range from 32 to 640 kbps. Possible settings for DTS(-ES) sources range from 754 to 1509.7kbps.

CENTER MIX LVL

-3.0dB, -4.5dB, -6.0dB

Indicates the relative center channel level that was used during the mixing process.

CHANNELS

3/3.1, 3/2.1, 3/2, 3/1, 2/2, 2/1, 2/0, 1/0

Indicates the number of channels present in the input source. The digit before the slash indicates the number of front channels. The digit after the slash indicates the number of surround channels. The digit after the decimal point indicates the presence of LFE (low-frequency effects) information. For instance, if the parameter setting is 3/2.1, an input source with three front channels, two surround channels and LFE information is present. LFE information is sent to the audio output connector labeled Subwoofer.

Possible settings for Dolby Digital sources include 3/2.1, 3/2, 3/1, 2/2, 2/1, 2/0 and 1/0. Possible settings for DTS(-ES) sources include 3/3.1 and 3/2.1.

DIALOG OFFSET

-27 to +4dB

Indicates the dialog normalization value applied to the input signal. Dolby Digital input sources reproduce dialog at 27 decibels below full-scale (-27dBFS). When the dialog normalization value of the incoming signal is higher or lower, the DIALOG OFFSET parameter indicates the amount of adjustment the MC-4 makes to normalize dialog to -27dBFS.

ES ENCODING

DISCRETE, MATRIX, OFF

Indicates whether a DTS-ES-encoded source is detected. When the parameter setting is DISCRETE, a discrete 6.1-channel DTS-ES source is detected. When the parameter setting is MATRIX, a 5.1-channel DTS-ES source with a surround-encoded back channel is detected. When the parameter setting is NONE, a standard DTS source with no DTS-ES encoding is detected.

EX ENCODING

MATRIX, NONE

Indicates whether a Dolby Digital Surround EX-encoded source is detected. When the parameter setting is MATRIX, a 5.1-channel Dolby Digital source recorded with Dolby Digital Surround EX is detected. When the parameter setting is NONE, a standard 5.1-channel Dolby Digital source recorded without Dolby Digital Surround EX-encoding is detected. The MC-4 cannot automatically detect Dolby Digital Surround EX encoding in non-flagged sources.

INPUT

Indicates the selected input (e.g., DVD1).

INPUT TYPE

ANLG, BYP, PCM, ---

Indicates the current input source. When the parameter setting is ANLG, a 2-channel analog audio source is present and the ADVANCED menu 2-CH ANLG BYP parameter is OFF. When the parameter setting is BYP, a 2-channel analog audio source is present and the 2-CH ANLG BYP parameter is ON. When the parameter setting is PCM, a 2-channel digital audio source is present. When the parameter setting is ---, an unknown digital audio source is present.

MIX ROOM

SMALL, LARGE

Indicates the size of the mixing room that was used during the mixing process. When the parameter setting is LARGE, set the RE-EQUALIZATION parameter to ON for THX listening modes.

MODE

Indicates the activated listening mode (e.g., L7 FILM).

SAMPLE RATE

44.1kHz, 48kHz, 88.2kHz, 96kHz

Indicates the sample rate of the current input source.

SURR MIX LVL

+0.0dB, -3.0dB, -6.0dB

Indicates the relative surround channel level that was used during the mixing process.

WORD LENGTH

16 bits, 20 bits, 24 bits

Indicates the word length of the audio data present in the input signal.

STATUS MENU LEVEL METERS

Most STATUS menus include level meters that indicate fluctuating input levels in the front left (L), center (C), front right (R), surround left (SL), surround right (SR), surround back (SB) and subwoofer (SUB) channels. These level meters indicate input levels for analog and digital input sources. For instance, the level meters indicate digital audio input levels when a digital audio source is present.

Different combinations of level meters appear on the STATUS menu, depending on the input source that is present. The SB level meter appears when a 6.1-channel source is present or when a 5.1-channel source is present and the ES DECODING parameter is set to ON.

Level meters appear in combinations of green, yellow and red when the on-screen display is configured for a blue screen background. Green indicates low levels, yellow indicates normal levels and red indicates high levels and the onset of overload. Level meters appear in white when the on-screen display is not configured for a blue screen background.

3

SETUP

SETUP	3-2
INPUT SETUP	3-3
<i>Changing Input Names (NAME) • Assigning Audio & Video Input Connectors • Selecting Preferred Listening Modes • Configuring Advanced Settings</i>	
SPEAKER SETUP	3-24
<i>Custom Speaker Setups • THX Speaker Setups • Measuring Speaker Distances • Calibrating Output Levels</i>	
REAR PANEL CONFIG.	3-43
DISPLAY SETUP	3-45
<i>On-Screen Display Setup • Front Panel Display Setup</i>	
VOLUME CONTROL SETUP	3-51
TRIGGER SETUP	3-52
LOCK OPTIONS	3-54

SETUP

Selecting the MAIN MENU SETUP option opens the SETUP menu as shown below.

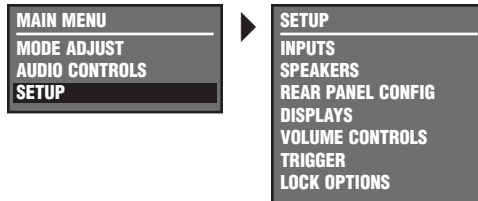

INPUTS

SETUP ▶ INPUTS

Prompts the selection of the desired input (e.g., DVD1). Selecting an input opens the corresponding INPUT SETUP menu, which can be used to change input names, assign audio and video input connectors, select preferred listening modes and configure advanced settings. See “INPUT SETUP” on page 3-3 for more information.

SPEAKERS

SETUP ▶ SPEAKERS

Opens the SPEAKER SETUP menu, which can be used to configure the audio output connectors for the desired speaker setup, set speaker distances and calibrate output levels. See “SPEAKER SETUP” on page 3-24 for more information.

REAR PANEL CONFIG

SETUP ▶ REAR PANEL CONFIG

Opens the REAR PANEL CONFIG menu, which can be used to configure the analog audio input connectors as eight stereo connectors, one 5.1-channel and five stereo connectors or two 5.1-channel and two stereo connectors. See “REAR PANEL CONFIG” on page 3-2 for more information.

DISPLAYS

SETUP ▶ DISPLAYS

Opens the DISPLAY SETUP menu, which can be used to customize the on-screen and front panel displays, restore audio/video synchronization and activate and create a custom unit name. See “DISPLAY SETUP” on page 3-45 for more information.

VOLUME CONTROLS

SETUP ▶ VOLUME CONTROLS

Opens the VOLUME CONTROL SETUP menu, which can be used to configure volume and mute levels. See “VOLUME CONTROL SETUP” on page 3-51 for more information.

TRIGGER

SETUP ▶ TRIGGER

Opens the TRIGGER SETUP menu, which can be used to configure the trigger output connector labeled 1. See “TRIGGER SETUP” on page 3-52 for more information.

LOCK OPTIONS

SETUP ▶ **LOCK OPTIONS**

Opens the LOCK OPTIONS menu, which can be used to lock and unlock settings in the MODE ADJUST, AUDIO CONTROLS and SETUP menu branches. See “LOCK OPTIONS” on page 3-54 for more information.

INPUT SETUP

SETUP ▶ **INPUTS** ▶ **(INPUT)** ▶ **INPUT SETUP**

Selecting the SETUP menu INPUTS option prompts the selection of the desired input (e.g., DVD1). Selecting an input opens the corresponding INPUT SETUP menu, which can be used to change input names, assign audio and video input connectors, select preferred listening modes and configure advanced settings.

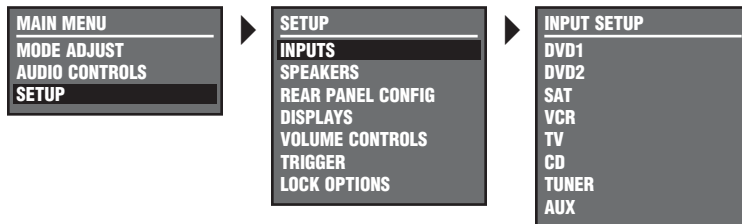

All INPUT SETUP menus are shown to the right. The parameters on the left side of the INPUT SETUP menu are identical regardless of which input is selected. The parameter settings on the right side are adjustable. Default parameter settings differ from input to input. The INPUT SETUP menus to the right indicate factory-default parameter settings.

DVD1 INPUT SETUP	
NAME	DVD1
DIGITAL IN	COAX-1
ANALOG IN	NONE
ANLG IN LVL	AUTO
VIDEO IN	S-VIDEO-1
COMPONENT IN	1
2-CH	<input type="checkbox"/> FILM
DOD	5.1 <input type="checkbox"/> FILM
<input type="checkbox"/> dts ES	<input type="checkbox"/> dts ES <input type="checkbox"/> FILM
ADVANCED	

VCR INPUT SETUP	
NAME	VCR
DIGITAL IN	NONE
ANALOG IN	ANALOG-2
ANLG IN LVL	AUTO
VIDEO IN	S-VIDEO-4
COMPONENT IN	NONE
2-CH	<input type="checkbox"/> FILM
DOD	5.1 <input type="checkbox"/> FILM
<input type="checkbox"/> dts ES	<input type="checkbox"/> dts ES <input type="checkbox"/> FILM
ADVANCED	

TUNER INPUT SETUP	
NAME	TUNER
DIGITAL IN	NONE
ANALOG IN	ANALOG-4
ANLG IN LVL	AUTO
VIDEO IN	NONE
COMPONENT IN	NONE
2-CH	<input type="checkbox"/> MUSIC
DOD	5.1 <input type="checkbox"/> MUSIC
<input type="checkbox"/> dts ES	<input type="checkbox"/> dts ES <input type="checkbox"/> MUSIC
ADVANCED	

DVD2 INPUT SETUP	
NAME	DVD2
DIGITAL IN	COAX-2
ANALOG IN	NONE
ANLG IN LVL	AUTO
VIDEO IN	S-VIDEO-2
COMPONENT IN	2
2-CH	<input type="checkbox"/> FILM
DOD	5.1 <input type="checkbox"/> FILM
<input type="checkbox"/> dts ES	<input type="checkbox"/> dts ES <input type="checkbox"/> FILM
ADVANCED	

TV INPUT SETUP	
NAME	TV
DIGITAL IN	OPTICAL-2
ANALOG IN	ANALOG-3
ANLG IN LVL	AUTO
VIDEO IN	S-VIDEO-5
COMPONENT IN	NONE
2-CH	<input type="checkbox"/> TV
DOD	5.1 <input type="checkbox"/> TV
<input type="checkbox"/> dts ES	<input type="checkbox"/> dts ES <input type="checkbox"/> FILM
ADVANCED	

AUX INPUT SETUP	
NAME	AUX
DIGITAL IN	OPTICAL-3
ANALOG IN	NONE
ANLG IN LVL	AUTO
VIDEO IN	COMPOSITE-2
COMPONENT IN	NONE
2-CH	<input type="checkbox"/> MUSIC
DOD	5.1 <input type="checkbox"/> MUSIC
<input type="checkbox"/> dts ES	<input type="checkbox"/> dts ES <input type="checkbox"/> MUSIC
ADVANCED	

SAT INPUT SETUP	
NAME	SAT
DIGITAL IN	OPTICAL-1
ANALOG IN	ANALOG-1
ANLG IN LVL	AUTO
VIDEO IN	S-VIDEO-3
COMPONENT IN	3
2-CH	<input type="checkbox"/> TV
DOD	5.1 <input type="checkbox"/> TV
<input type="checkbox"/> dts ES	<input type="checkbox"/> dts ES <input type="checkbox"/> FILM
ADVANCED	

CD INPUT SETUP	
NAME	CD
DIGITAL IN	COAX-3
ANALOG IN	NONE
ANLG IN LVL	AUTO
VIDEO IN	COMPOSITE-1
COMPONENT IN	NONE
2-CH	<input type="checkbox"/> MUSIC
DOD	5.1 <input type="checkbox"/> MUSIC
<input type="checkbox"/> dts ES	<input type="checkbox"/> dts ES <input type="checkbox"/> MUSIC
ADVANCED	

CHANGING INPUT NAMES (NAME)

Selecting the INPUT SETUP menu NAME parameter opens the INPUT NAME menu, which can be used to customize or restore the factory-default name of the selected input. Factory-default input names correspond to front panel and remote control input selection button labels.

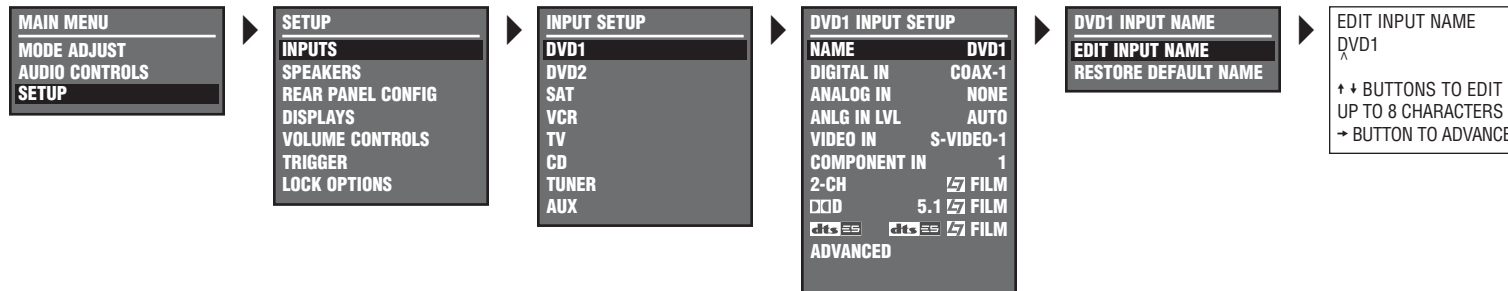

The DVD1 INPUT SETUP menu is shown here as an example and will continue to be shown as an example throughout this section. Whenever it appears, any other INPUT SETUP menu can be substituted. Likewise, whenever the DVD1 input appears as a step in a menu path, any other input can be substituted.

EDIT INPUT NAME

SETUP ▶ **INPUTS** ▶ **DVD1** ▶ **NAME** ▶ **EDIT INPUT NAME**

Opens the EDIT INPUT NAME drop-down menu, which can be used to customize the name of the selected input.

To customize the name of the selected input:

1. Follow the EDIT INPUT NAME menu path to open the EDIT INPUT NAME drop-down menu.
2. When the EDIT INPUT NAME drop-down menu opens, press the remote control **Menu** **▲** and **▼** arrows to change the character above the cursor (^).
3. When the desired character has been selected, press the **Menu** **▶** arrow to advance to the next character space. Press the **Menu** **◀** arrow to return to the previous character space. The cursor will automatically wrap to the first character space when the last character space is passed.
4. Repeat steps 2 and 3 to enter the desired input name.
5. When the desired input name has been entered, press the **Menu** **◀** arrow to close the EDIT INPUT NAME drop-down menu and return to the INPUT NAME menu.

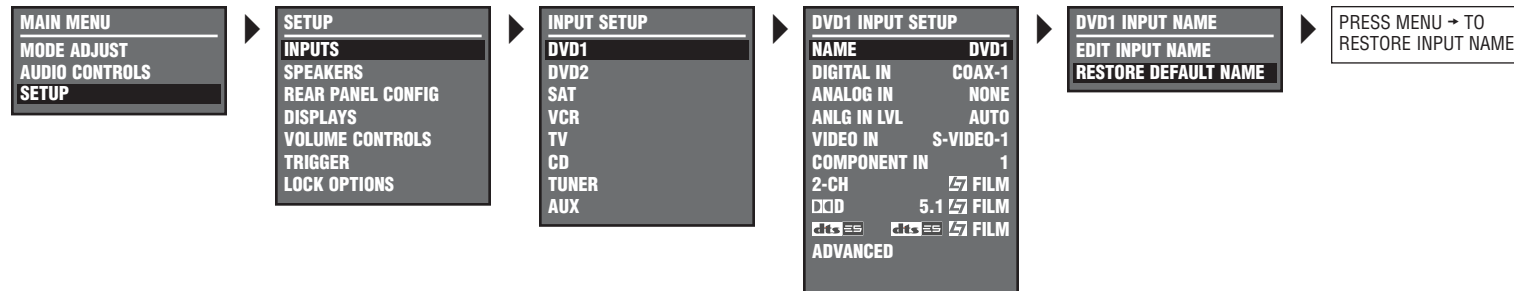

The custom input name appears on the on-screen and front panel displays. Both the custom and factory-default input names appear on the input selection menu that opens when the SETUP menu INPUTS option is selected. The custom input name appears against the left margin of the on-screen display and the factory-default input name appears in parentheses against the right margin of the on-screen display.

RESTORE DEFAULT NAME

SETUP ▶ **INPUTS** ▶ **DVD1** ▶ **NAME** ▶ **RESTORE DEFAULT NAME**

Restores the factory-default name of the selected input. Factory-default input names correspond to front panel and remote control input selection button labels.

To restore the factory-default name of the selected input:

1. Follow the RESTORE DEFAULT NAME menu path to open the INPUT NAME menu.
2. When the INPUT NAME menu opens, press the **Menu** ▲ and ▼ **arrows** to highlight the RESTORE DEFAULT NAME option.
3. When the RESTORE DEFAULT NAME option is highlighted, press the **Menu** ▶ **arrow** to select this option. The message PRESS MENU → TO RESTORE INPUT NAME appears on the on-screen and front panel displays.
4. When this message opens, press the **Menu** ▶ **arrow** to restore the factory-default name of the selected input and close the message. (Press the **Menu** ◀ **arrow** to close the message without restoring the factory-default name of the selected input.)

ASSIGNING AUDIO & VIDEO INPUT CONNECTORS

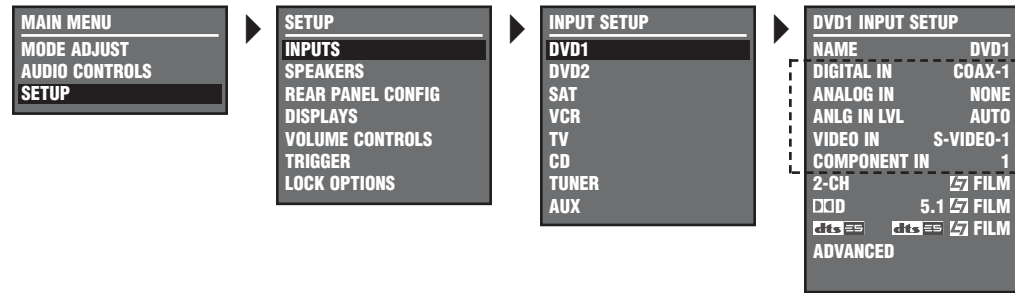

The MC-4 has eight configurable inputs, each of which can be assigned to its eight digital audio, eight analog audio, five composite video, five S-video or three component video input connectors. The table below lists the INPUT SETUP menu parameters that can be used to assign audio and video input connectors. The ANLG IN LVL parameter adjusts analog audio input levels for the selected input. These parameters are highlighted on the INPUT SETUP menu shown above.

Parameter	Possible Settings
DIGITAL IN	COAX-1 to 4, OPTICAL-1 to 4, NONE
ANALOG IN	ANALOG-1 to 8, 5.1 ANLG (3–5) or (6–8), NONE
ANLG IN LVL	AUTO, –18dB to +12dB
VIDEO IN	COMPOSITE-1 to 5, S-VIDEO-1 to 5, NONE
COMPONENT IN	COMPONENT 1 to 3, NONE

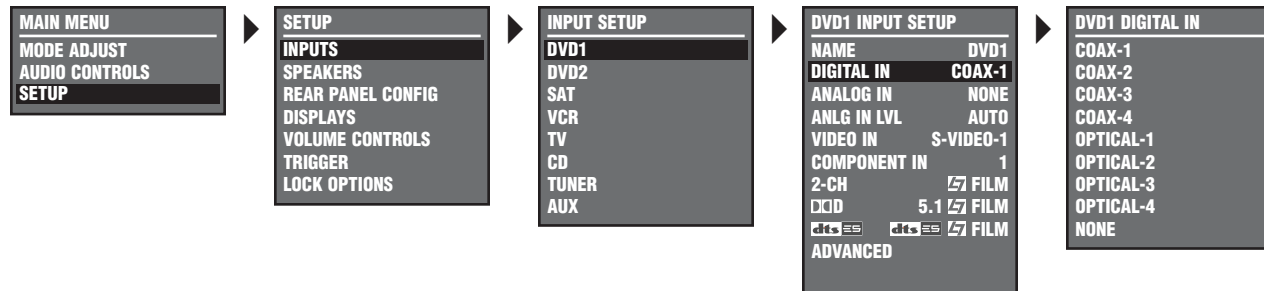

DIGITAL IN COAX-1 to 4, OPTICAL-1 to 4, NONE

SETUP ▶ **INPUTS** ▶ **DVD1** ▶ **DIGITAL IN**

Opens the DIGITAL IN menu, which assigns a digital audio input connector for the selected input. The MC-4 has eight configurable inputs, each of which can be assigned to any of its eight digital audio input connectors.

Note:

The digital audio input connectors are compatible with PCM (44.1kHz, 48kHz, 88.2kHz and 96kHz), Dolby Digital and DTS(-ES) sources. The digital audio input connectors are not compatible with MPEG (MP3) sources.

Please note the following:

- When no digital audio input connector is assigned, the MC-4 will automatically set the ADVANCED menu INPUT SELECT parameter to ANALOG. See “Configuring Advanced Settings” on page 3-17 for more information.
- A digital audio input connector must be assigned when no analog audio input connector is assigned. See “ANALOG IN” on page 3-8 for information about assigning an analog audio input connector.

Assigning Audio & Video Input Connectors (continued)

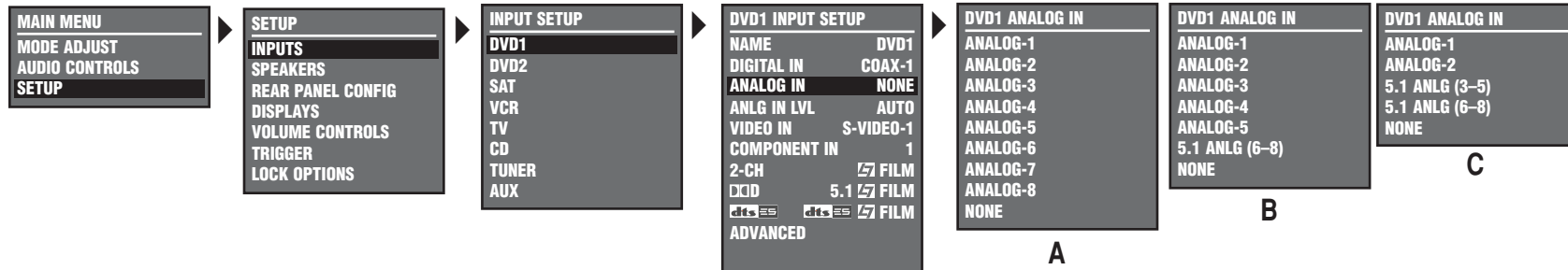

ANALOG IN ANALOG-1 to 8, 5.1 ANLG (3–5) or (6–8), NONE

SETUP ▶ **INPUTS** ▶ **DVD1** ▶ **ANALOG IN**

Opens the ANALOG IN menu, which assigns an analog audio input connector for the selected input. The MC-4 has eight configurable inputs, each of which can be assigned to any of its eight analog audio input connectors.

The appearance of the ANALOG IN menu depends on the configuration of the analog audio input connectors.

- The ANALOG IN menu labeled A (above) appears when the REAR PANEL CONFIG menu 8 STEREO INPUTS option is selected.
- The ANALOG IN menu labeled B (above) appears when the REAR PANEL CONFIG menu 5 ST. & (1) 5.1 ANLG option is selected.
- The ANALOG IN menu labeled C (above) appears when the REAR PANEL CONFIG menu 2 ST. & (2) 5.1 ANLG option is selected.

Please note the following:

- When no analog audio input connector is assigned, the MC-4 will automatically set the ADVANCED menu INPUT SELECT parameter to DIGITAL. See “Configuring Advanced Settings” on page 3-17 for more information.
- An analog audio input connector must be assigned when no digital audio input connector is assigned. See “DIGITAL IN” on page 3-7 for information about assigning a digital audio input connector.

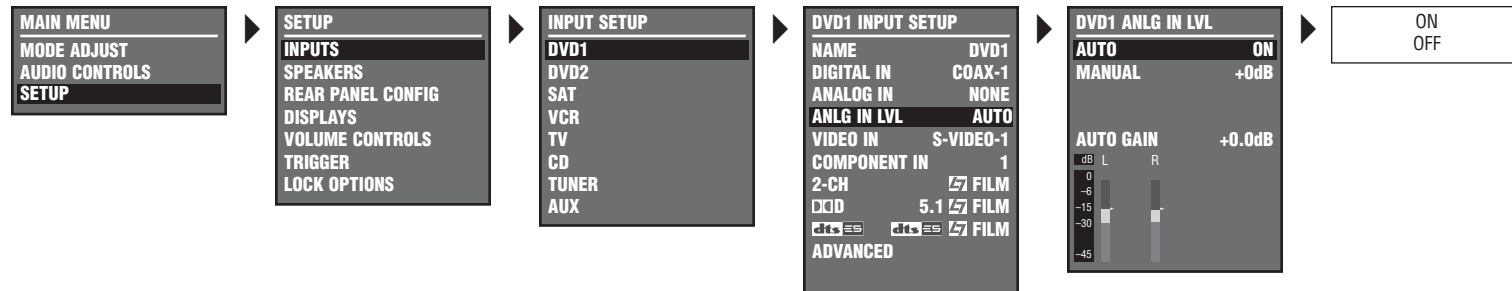

ANLG IN LVL

SETUP ▶ INPUTS ▶ DVD1 ▶ ANLG IN LVL

Opens the ANLG IN LVL menu, which adjusts 2-channel analog audio input levels for the selected input. Despite attempts at standardization, analog audio sources have a wide range of levels. To compensate for this, the MC-4 allows independent input level adjustment for each of its stereo analog audio input connectors.

Input level adjustment is not available for either of the 5.1-channel analog audio input connectors.

Note:

Adjustments made on the ANLG IN LVL menu are applied to the stereo analog audio input connector assigned for the selected input. When another stereo analog audio input connector is assigned, these adjustments are automatically applied to the new connector.

AUTO

ON, OFF

SETUP ▶ INPUTS ▶ DVD1 ▶ ANLG IN LVL ▶ AUTO

Provides automatic adjustment of 2-channel analog audio input levels. When ON, the MC-4 automatically monitors and optimizes input levels. When the input signal is too high, the MC-4 quickly decreases input levels to avoid overload. When the input signal is too low, the MC-4 slowly increases input levels to maximize signal-to-noise ratio and dynamic range.

When the AUTO parameter is OFF, the MC-4 does not provide automatic adjustment of 2-channel analog audio input levels. Rather, input levels must be adjusted with the ANLG IN LVL menu MANUAL parameter.

Assigning Audio & Video Input Connectors (continued)

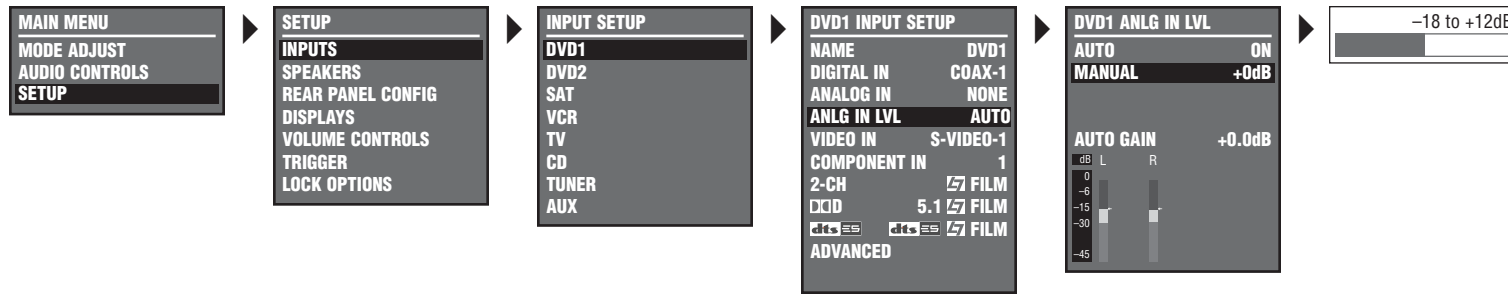

MANUAL

-18dB to +12dB

SETUP ▶ INPUTS ▶ DVD1 ▶ ANLG IN LVL ▶ MANUAL

Provides manual adjustment of 2-channel analog audio input levels. When manual adjustments are made, the MC-4 automatically sets the ANLG IN LVL menu AUTO parameter to OFF and deactivates automatic input level adjustment. Manual input level adjustments are retained when the AUTO parameter ON.

Note:

When the AUTO parameter is ON, the MC-4 will not make adjustments that exceed the ANLG IN LVL menu MANUAL parameter setting.

AUTO GAIN

SETUP ▶ INPUTS ▶ DVD1 ▶ ANLG IN LVL ▶ AUTO GAIN

Indicates the current amount of input level adjustment for the selected stereo analog audio input connector. When the ANLG IN LVL menu AUTO parameter is ON, the AUTO GAIN parameter indicates the amount of automatic input level adjustment. When the AUTO parameter is OFF, the AUTO GAIN parameter indicates the amount of manual input level adjustment. (In other words, the AUTO GAIN parameter reflects the setting of the ANLG IN LVL menu MANUAL parameter.)

When the AUTO parameter is ON, the AUTO GAIN parameter continues to indicate the amount of manual input level adjustment until automatic adjustments have been made.

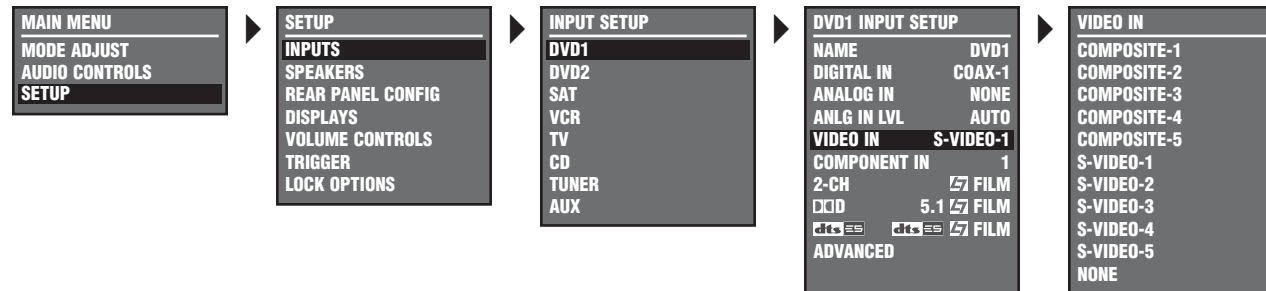

LEVEL METERS

SETUP ▶ INPUTS ▶ DVD1 ▶ ANLG IN LVL

Indicate fluctuating input levels in the front left (L) and front right (R) channels for the selected input. These level meters are also included on the STATUS menus, allowing them to indicate input levels for both analog and digital audio input sources. However, ANLG IN LVL menu input level adjustments only affect 2-channel analog audio input sources.

Level meters appear in combinations of green, yellow and red when the on-screen display is configured for a blue screen background. Green indicates low levels; yellow indicates normal levels; and red indicates the onset of overload. Level meters appear in white when the on-screen display is not configured for a blue screen background.

VIDEO IN

COMPOSITE-1 to 5, S-VIDEO-1 to 5, NONE

SETUP ▶ INPUTS ▶ DVD1 ▶ VIDEO IN

Opens the VIDEO IN menu, which assigns a composite or S-video input connector for the selected input. The MC-4 has eight configurable inputs, each of which can be assigned to any of its five composite or five S-video input connectors.

Note:

- Composite video output connectors are available when a composite or S-video source is present.
 - S-video output connectors are available when an S-video source is present.
-

Assigning Audio & Video Input Connectors *(continued)*

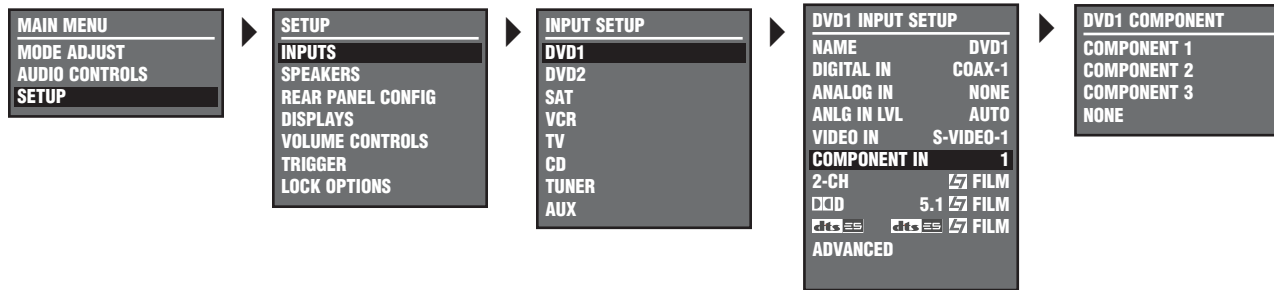

COMPONENT IN COMPONENT 1 to 3, NONE

SETUP ▶ **INPUTS** ▶ **DVD1** ▶ **COMPONENT IN**

Opens the COMPONENT menu, which assigns a component video input connector for the selected input. The MC-4 has eight configurable inputs, each of which can be assigned to any of its three component video input connectors.

Note:

- Component video output connectors are available when a component video source is present.

SELECTING PREFERRED LISTENING MODES

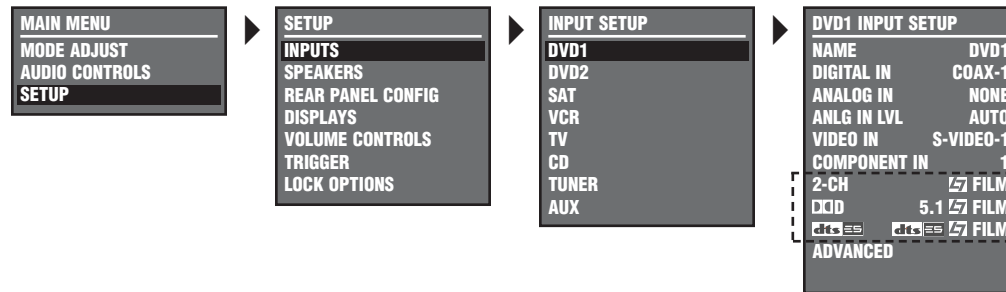

The INPUT SETUP menu includes three preferred listening mode selection parameters labeled 2-CH, DOLBY D and DTS-ES. These parameters select a preferred listening mode for 2-channel, Dolby Digital and DTS(-ES) input sources. The MC-4 automatically activates the selected listening mode whenever a new input is selected or a new input source is present.

For example, the preferred listening mode selection parameters on the DVD1 and CD INPUT SETUP menus are set as shown to the right.

DVD1 INPUT SETUP	
NAME	DVD1
DIGITAL IN	COAX-1
ANALOG IN	NONE
ANLG IN LVL	AUTO
VIDEO IN	S-VIDEO-1
COMPONENT IN	1
2-CH	L7 FILM
DDD	5.1 L7 FILM
DTS-ES	L7 FILM
ADVANCED	

CD INPUT SETUP	
NAME	CD
DIGITAL IN	COAX-3
ANALOG IN	NONE
ANLG IN LVL	AUTO
VIDEO IN	COMPOSITE-1
COMPONENT IN	NONE
2-CH	L7 MUSIC
DDD	5.1 L7 MUSIC
DTS-ES	L7 MUSIC
ADVANCED	

- If the DVD1 input is selected and a 2-channel source is present, the MC-4 activates the L7 FILM listening mode. If a Dolby Digital source becomes present, the MC-4 automatically activates the 5.1 L7 FILM listening mode.
- If the DVD1 input is selected and a DTS(-ES) source is present, the MC-4 activates the DTS(-ES) L7 FILM listening mode. If the CD input is selected and a 2-channel source is present, the MC-4 automatically activates the L7 MUSIC listening mode.

Selecting Preferred Listening Modes (continued)

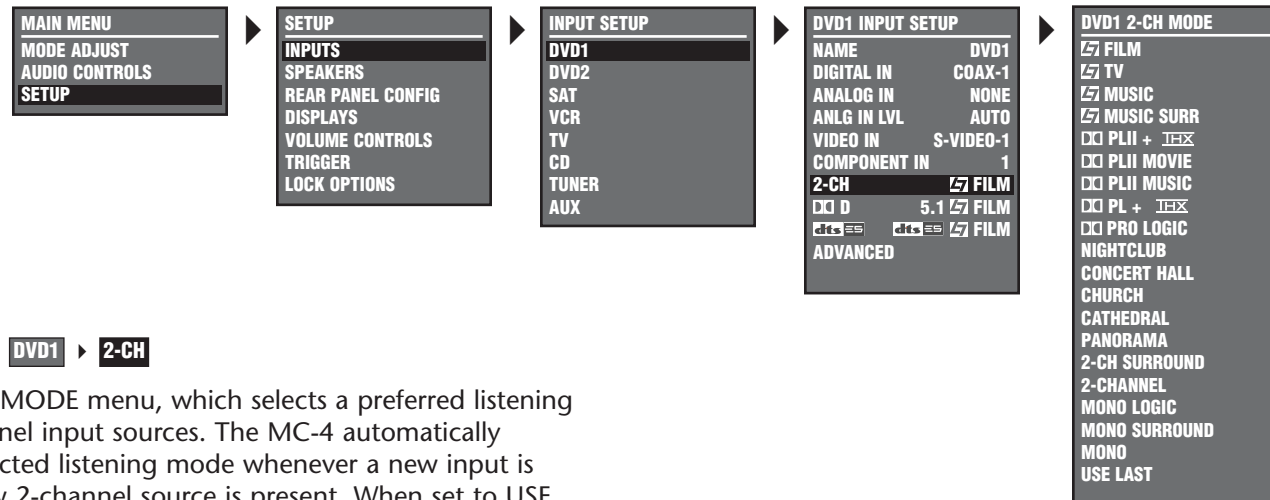

2-CH

SETUP ▶ INPUTS ▶ DVD1 ▶ 2-CH

Opens the 2-CH MODE menu, which selects a preferred listening mode for 2-channel input sources. The MC-4 automatically activates the selected listening mode whenever a new input is selected or a new 2-channel source is present. When set to USE LAST, the MC-4 activates the listening mode that was activated the last time a 2-channel source was present.

When the 2-CH parameter is set to USE LAST:

- The MC-4 will not automatically activate the 2-CHANNEL listening mode if the remote control 2 CH button was used to activate the 2-CHANNEL listening mode the last time a 2-channel source was present. Instead, it will activate the 2-channel listening mode (e.g., L7 FILM) that was activated prior to the 2-CHANNEL listening mode.
- The MC-4 will automatically activate a DTS Neo:6 listening mode if a DTS Neo:6 listening mode was activated the last time a 2-channel source was present. However, the DTS Neo:6 listening modes cannot be selected as the preferred listening mode for 2-channel sources.

- The MC-4 will not automatically activate a DTS Neo:6 listening mode unless a 44.1kHz or 48kHz PCM digital source is present. The DTS Neo:6 listening modes are not available with 88.2kHz or 96kHz, Dolby Digital or analog sources.

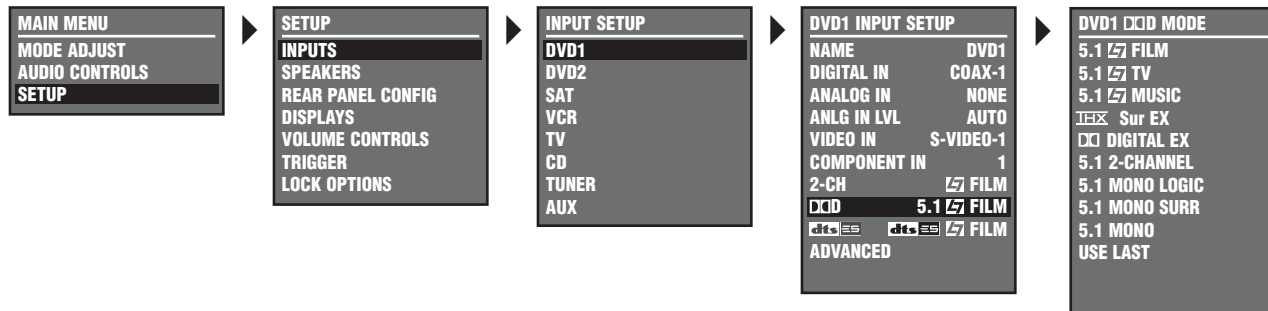

DDD

SETUP ▶ **INPUTS** ▶ **DVD1** ▶ **DDD**

Opens the DDD MODE menu, which selects a preferred listening mode for Dolby Digital input sources. The MC-4 automatically activates the selected listening mode whenever a new input is selected or a new Dolby Digital source is present. When set to USE LAST, the MC-4 activates the listening mode that was activated the last time a Dolby Digital source was present.

When the DDD parameter is set to USE LAST:

- The MC-4 will automatically activate the 5.1 THX MUSIC listening mode if this listening mode was activated the last time a Dolby Digital source was present. However, the 5.1 THX MUSIC listening mode cannot be selected as the preferred listening mode for Dolby Digital sources.

Selecting Preferred Listening Modes (continued)

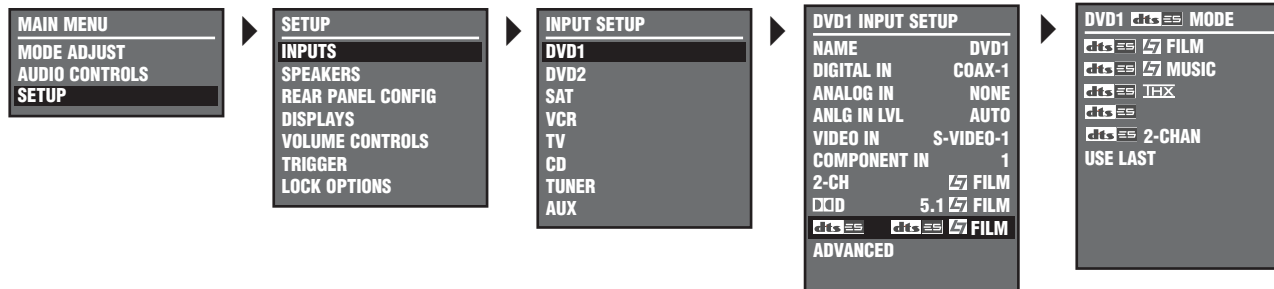

SETUP ▶ INPUTS ▶ DVD1 ▶ [DTS-ES]

Opens the DTS-ES MODE menu, which selects a preferred listening mode for DTS(-ES) input sources. The MC-4 automatically activates the selected listening mode whenever a new input is selected or a new DTS(-ES) source is present. When set to USE LAST, the MC-4 activates the listening mode that was activated the last time a DTS(-ES) source was present.

When the [DTS-ES] parameter is set to USE LAST:

- The MC-4 will automatically activate the DTS THX MUSIC listening mode if this listening mode was activated the last time a DTS(-ES) source was present. However, the DTS THX MUSIC listening mode cannot be selected as the preferred listening mode for DTS(-ES) sources.

CONFIGURING ADVANCED SETTINGS

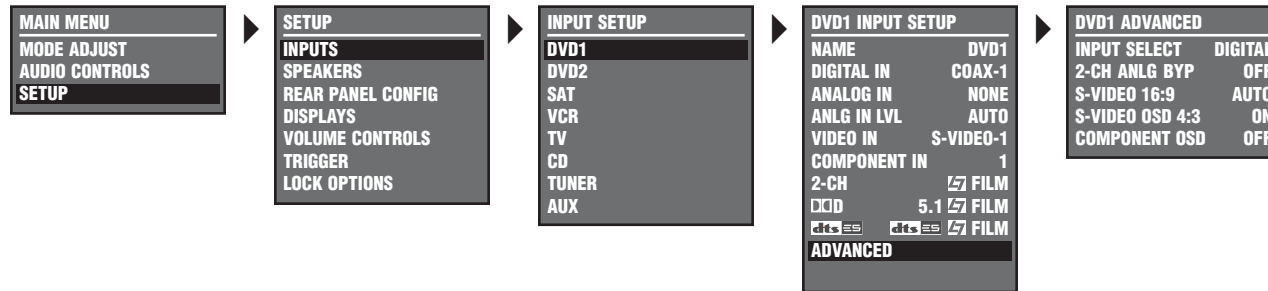

ADVANCED

SETUP ▶ **INPUTS** ▶ **DVD1** ▶ **ADVANCED**

Selecting the INPUT SETUP menu ADVANCED option opens the ADVANCED menu. The parameters on the left side of this menu are identical regardless of which input is selected. The settings on the right side are adjustable. Default parameter settings differ from input to input. The ADVANCED menus shown to the right indicate default parameter settings for each input.

DVD1 ADVANCED	
INPUT SELECT	DIGITAL
2-CH ANLG BYP	OFF
S-VIDEO 16:9	AUTO
S-VIDEO OSD 4:3	ON
COMPONENT OSD	OFF

VCR ADVANCED	
INPUT SELECT	ANALOG
2-CH ANLG BYP	OFF
S-VIDEO 16:9	AUTO
S-VIDEO OSD 4:3	ON
COMPONENT OSD	OFF

TUNER ADVANCED	
INPUT SELECT	ANALOG
2-CH ANLG BYP	OFF
S-VIDEO 16:9	AUTO
S-VIDEO OSD 4:3	ON
COMPONENT OSD	OFF

DVD2 ADVANCED	
INPUT SELECT	DIGITAL
2-CH ANLG BYP	OFF
S-VIDEO 16:9	AUTO
S-VIDEO OSD 4:3	ON
COMPONENT OSD	OFF

TV ADVANCED	
INPUT SELECT	AUTO
2-CH ANLG BYP	OFF
S-VIDEO 16:9	AUTO
S-VIDEO OSD 4:3	ON
COMPONENT OSD	OFF

AUX ADVANCED	
INPUT SELECT	DIGITAL
2-CH ANLG BYP	OFF
S-VIDEO 16:9	AUTO
S-VIDEO OSD 4:3	ON
COMPONENT OSD	OFF

SAT ADVANCED	
INPUT SELECT	AUTO
2-CH ANLG BYP	OFF
S-VIDEO 16:9	AUTO
S-VIDEO OSD 4:3	ON
COMPONENT OSD	OFF

CD ADVANCED	
INPUT SELECT	DIGITAL
2-CH ANLG BYP	OFF
S-VIDEO 16:9	AUTO
S-VIDEO OSD 4:3	ON
COMPONENT OSD	OFF

Configuring Advanced Settings (continued)

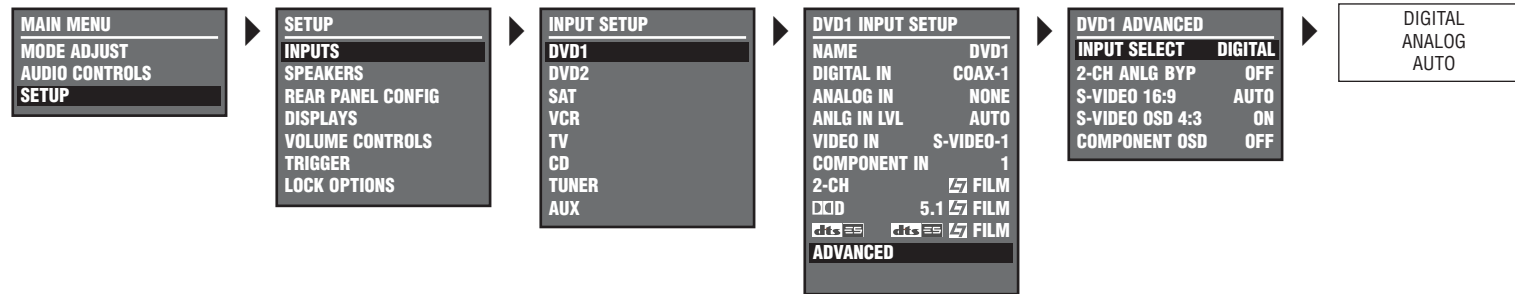

INPUT SELECT DIGITAL, ANALOG, AUTO

SETUP ▶ **INPUTS** ▶ **DVD1** ▶ **ADVANCED** ▶ **INPUT SELECT**

Controls the interaction of the digital and analog audio input connectors assigned for the selected input. The INPUT SETUP menu can be used to assign one digital and one analog audio input connector for the selected input. See “DIGITAL IN” on page 3-7 and “ANALOG IN” on page 3-8 for more information.

Pressing and holding the S1 button while pressing and releasing the 7/5 button adjusts the INPUT SELECT parameter, cycling through the DIGITAL, ANALOG and AUTO settings.

The table shown on the next page describes INPUT SELECT parameter settings.

Note:

When the INPUT SELECT parameter is set to AUTO, the MC-4 will not select the assigned analog audio input connector when a valid digital audio input source is present. Some DVD and CD players output digital signals (data) when the player is paused or stopped or when the player is powered on and the disc drawer is empty. If this occurs, the MC-4 automatically selects the assigned digital audio input connector.

INPUT SELECT Parameter Settings

The table below describes INPUT SELECT parameter settings.

DIGITAL	ANALOG	AUTO
<p>The MC-4 automatically sets the INPUT SELECT parameter to DIGITAL when no analog audio input connector is assigned.</p> <ul style="list-style-type: none"> The MC-4 sends the assigned digital audio input connector to the audio output connectors. The MC-4 ignores the assigned analog audio input connector. The digital audio input connectors are compatible with PCM (44.1kHz, 48kHz, 88.2kHz and 96kHz), Dolby Digital and DTS(-ES) sources. If an incompatible digital audio source (e.g., MPEG or MP3) is present, the MC-4 automatically selects the assigned analog audio input connector. The DIGITAL IN parameter assigns a digital audio input connector for the selected input. 	<p>The MC-4 automatically sets the INPUT SELECT parameter to ANALOG when no digital audio input connector is assigned.</p> <ul style="list-style-type: none"> The MC-4 sends the assigned analog audio input connector to the audio output connectors. The MC-4 ignores the assigned digital audio input connector. The ANALOG IN parameter assigns an analog audio input connector for the selected input. 	<p>The MC-4 automatically sets the INPUT SELECT parameter to AUTO when both digital and analog audio input connectors are assigned.</p> <ul style="list-style-type: none"> The MC-4 sends either the assigned digital and analog audio input connector to the audio output connectors based on the input source that is present. For example: <ul style="list-style-type: none"> When a 2-channel PCM, Dolby Digital or DTS(-ES) source is present, the MC-4 automatically sends the input source to the assigned digital audio input connector. When an SACD™ source is present, the MC-4 automatically sends the input source to the assigned analog audio input connector. The AUTO setting is recommended for components that generate both digital and analog signals, such as DVD/SACD players.

Configuring Advanced Settings *(continued)*

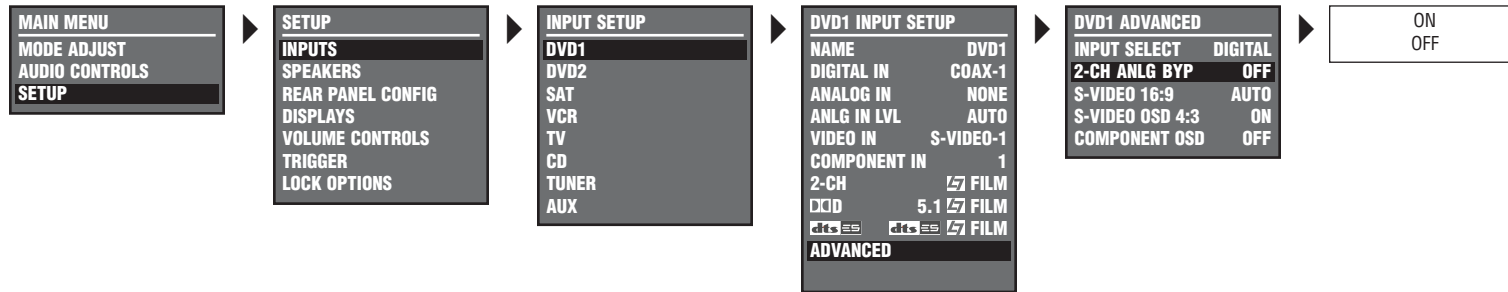

2-CH ANLG BYP

ON, OFF

SETUP ▶ INPUTS ▶ DVD1 ▶ ADVANCED ▶ 2-CH ANLG BYP

Allows 2-channel analog audio input sources to bypass A/D conversion and internal processing. When ON, the MC-4 passes analog audio input signals to the corresponding audio output connectors. When a 5.1-channel analog audio source is present, the MC-4 passes only (L) and (R) analog audio input signals to the audio output connectors labeled Front L/R. When set to OFF, all analog audio input signals are sent through A/D conversion and internal processing before passing to the audio output connectors.

Note:

Pressing and holding the S1 button while pressing and releasing the remote control 2 CH button toggles the 2-CH ANLG BYP parameter setting between ON and OFF.

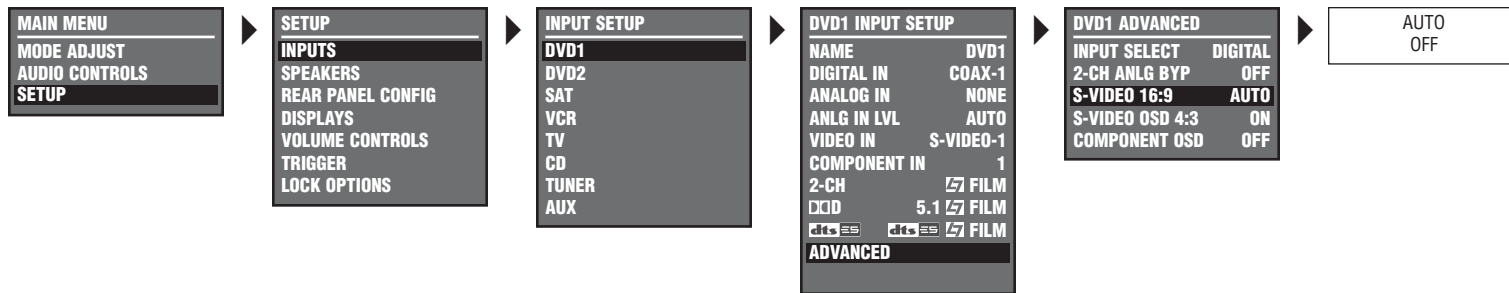
**S-VIDEO 16:9**

AUTO, OFF

SETUP ▶ **INPUTS** ▶ **DVD1** ▶ **ADVANCED** ▶ **S-VIDEO 16:9**

Controls the passage of anamorphic trigger signals present in some video sources. When set to AUTO, the MC-4 allows anamorphic video input signals to pass through the S-video switcher, enabling compatible display devices to automatically switch between anamorphic and non-anamorphic display modes. When OFF, the MC-4 prevents anamorphic video input signals from passing through the S-video switcher, preventing compatible display devices from automatically switching between anamorphic and non-anamorphic display modes.

Configuring Advanced Settings (continued)

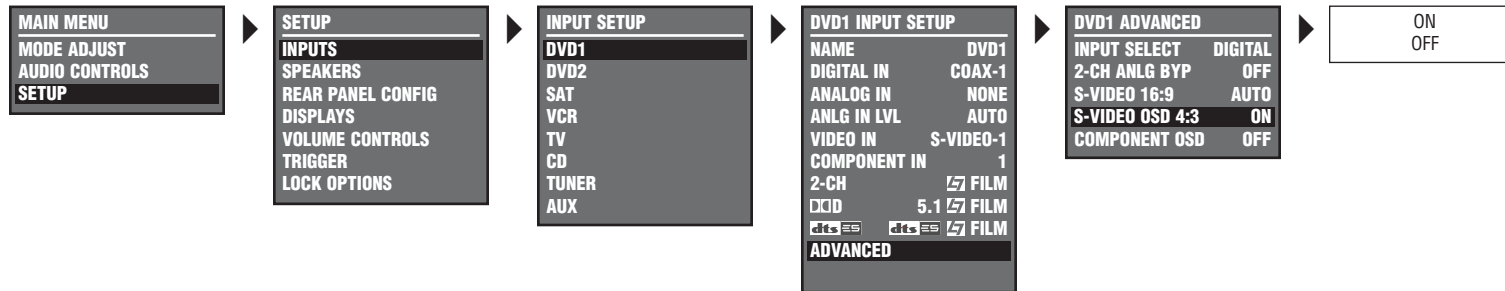

S-VIDEO OSD 4:3

ON, OFF

SETUP ▶ INPUTS ▶ DVD1 ▶ ADVANCED ▶ S-VIDEO OSD 4:3

Controls the appearance of the on-screen display when the display device is connected to an S-video output connector. When ON, the display device shows the on-screen display in a 4:3 aspect ratio* regardless of the incoming signal. When OFF, the display device shows the on-screen display in the same aspect ratio as the input signal.

* **Aspect ratio** refers to the size of the picture on the display device screen or to the size of the display device screen. A 4:3 aspect ratio is almost square. A 16:9 aspect ratio, often referred to as widescreen, is almost twice as wide as it is high.

Note:

The on-screen display appears horizontally stretched across the display device screen when all of the following conditions are present:

- The S-VIDEO OSD (4:3) parameter is OFF.
- An anamorphic video input signal is present.
- A 16:9 display device (widescreen) is connected to an S-video output connector.

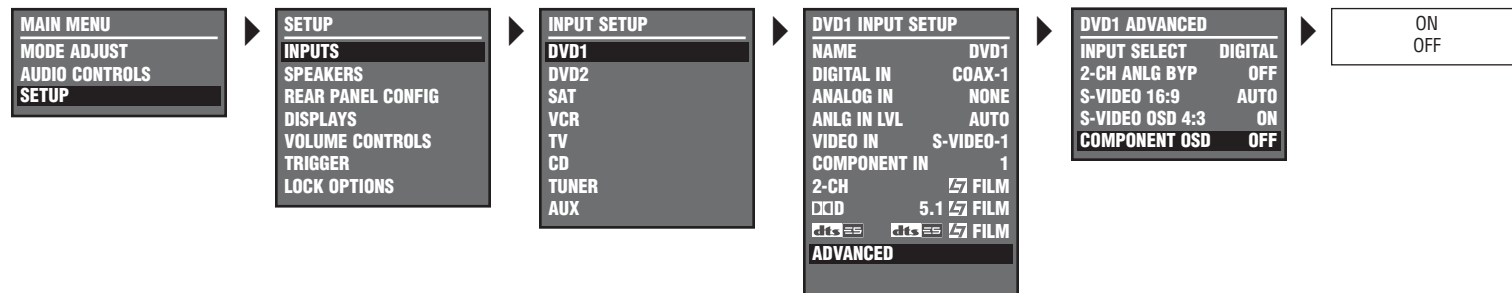

COMPONENT OSD

ON, OFF

SETUP ▸ INPUTS ▸ DVD1 ▸ ADVANCED ▸ COMPONENT OSD

Controls the appearance of the on-screen display when the display device is connected to the component video output connector. When ON, the display device shows the on-screen display as a 480i video signal on a full blue screen background. To minimize viewing distractions, the two-line status does not appear on the on-screen display. When OFF, the display device does not show the on-screen display, including the two-line status.

Note:

When the ON-SCREEN DISPLAY menu BACKGROUND parameter is OFF, the display device using the component video output connector will not show the on-screen display.

SPEAKER SETUP

SETUP ▶ **SPEAKERS** ▶ **SPEAKER SETUP**

Selecting the SETUP menu SPEAKERS option opens the SPEAKER SETUP, which can be used to configure the audio output connectors for the desired speaker setup, set speaker distances and calibrate output levels. The MC-4 has eight audio output connectors labeled Front L/R, Center, Subwoofer, Side L/R and Rear L/R.

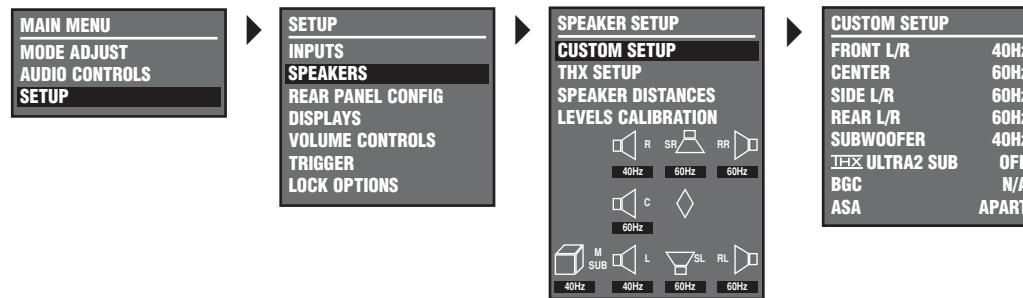

CUSTOM SPEAKER SETUPS

SETUP ▶ **SPEAKERS** ▶ **CUSTOM SETUP**

Selecting the SPEAKER SETUP menu CUSTOM SETUP option opens the CUSTOM SETUP menu, which can be used to configure the audio output connectors for a custom speaker setup. The CUSTOM SETUP menu allows the selection of independent crossover points for each audio output connector.

Determining Crossover Points

The CUSTOM SETUP menu allows independent crossover points to be assigned for each audio output connector. Crossover points can be selected in 10Hz increments within a 30Hz–120Hz range. With the exception of THX 80Hz, all crossover points activate a 24dB per-octave filter. The graphs on the next page indicate the frequency response of these crossover points.

The THX 80Hz crossover point activates a 12dB per-octave filter for the audio output connectors labeled Front L/R, Center, Side L/R and Rear L/R and a 24dB per-octave filter for the audio output connector labeled Subwoofer.

For each audio output connector, select the crossover point closest to the low-frequency rating of the associated loudspeaker. For the output connector labeled Subwoofer, select the crossover point equal to the lowest crossover point of the other loudspeakers.

In general, low frequencies will be redirected from loudspeakers with the highest crossover points to loudspeakers with the lowest crossover points. Low-frequency signals lower than the lowest crossover point will be redirected to the subwoofer. If the lowest crossover point is FULL, low-frequency signals, excluding LFE information, will not be redirected to the subwoofer.

High-Pass Filter

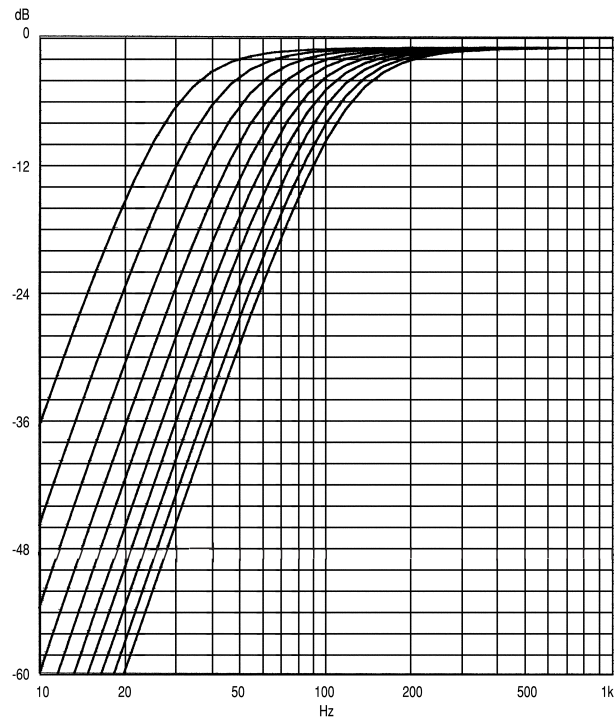

High-pass filters attenuate low frequencies at 24dB per octave. The curves in the graph above indicate the frequency response of each crossover setting. From left to right, the curves represent crossover settings from 30Hz–120Hz. The graph above does not show the THX 80Hz crossover point, which is 12dB per octave.

Low-Pass Filter

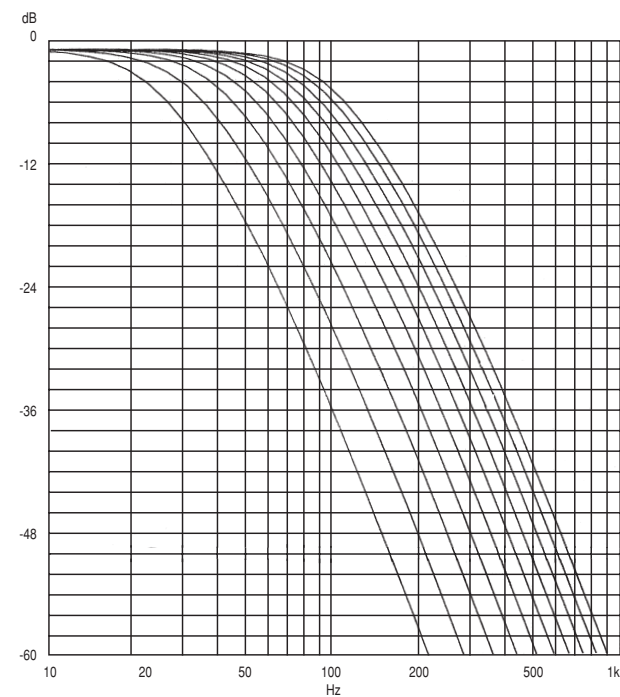

Low-pass filters attenuate high frequencies at 24dB per octave. The curves in the graph above indicate the frequency response of each crossover setting. From left to right, the curves represent crossover settings from 30Hz–120Hz.

Custom Speaker Setups (continued)

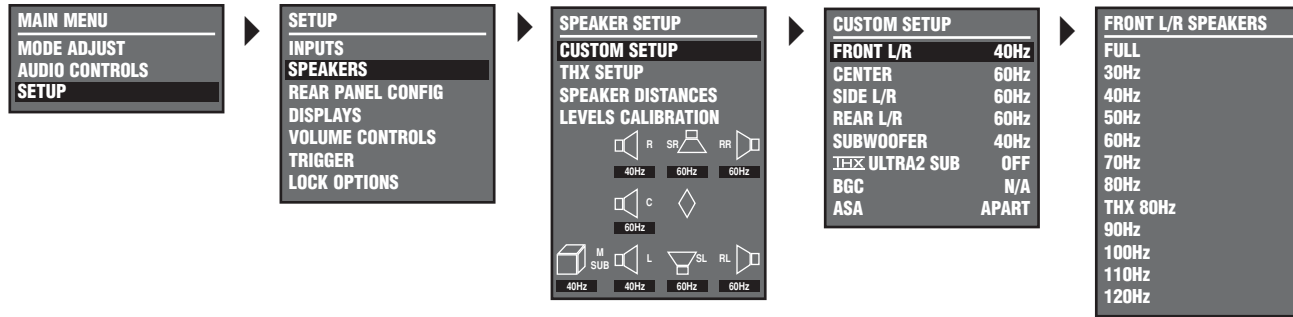

Parameter	Default Setting	Possible Settings
FRONT L/R	40Hz	FULL, 30Hz–120Hz, THX 80Hz
CENTER	60Hz	FULL, 30Hz–120Hz, THX 80Hz, NONE
SIDE L/R	60Hz	FULL, 30Hz–120Hz, THX 80Hz, NONE
REAR L/R	60Hz	FULL, 30Hz–120Hz, THX 80Hz, NONE
SUBWOOFER	40Hz	FULL, 30Hz–120Hz, THX 80Hz, NONE
THX ULTRA2 SUB	OFF	ON, OFF
BGC	N/A	ON, OFF
ASA	APART	TOGETHER, CLOSE, APART

FRONT L/R

FULL, 30Hz–120Hz, THX 80Hz

SETUP ▶ **SPEAKERS** ▶ **CUSTOM SETUP** ▶ **FRONT L/R**

Opens the FRONT L/R SPEAKERS menu, which can be used to select a crossover point for the audio output connectors labeled Front L/R. When set to FULL, the MC-4 sends a full-range audio signal to these connectors. Otherwise, the MC-4 activates a crossover point at the selected setting. Choose the setting closest to the low-frequency rating of the front loudspeakers.

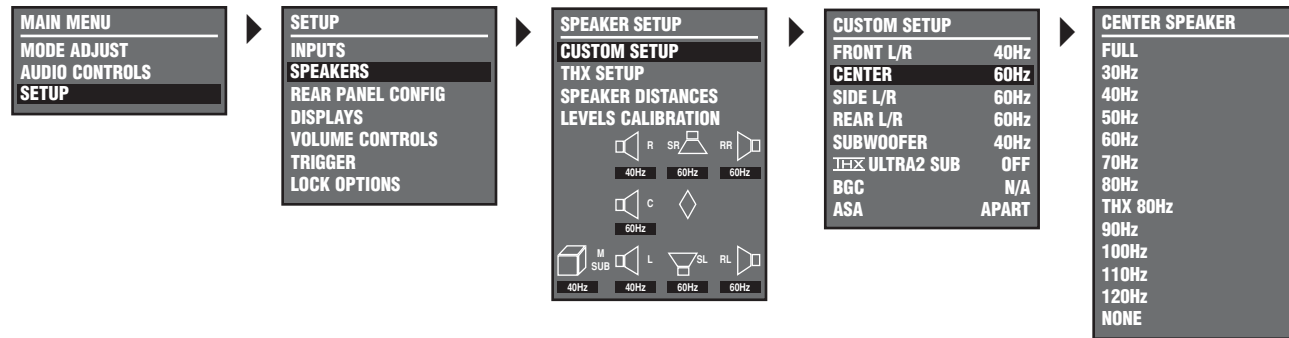

CENTER

FULL, 30Hz–120Hz, THX 80Hz, NONE

SETUP ▶ **SPEAKERS** ▶ **CUSTOM SETUP** ▶ **CENTER**

Opens the CENTER SPEAKER menu, which can be used to select a crossover point for the audio output connector labeled Center. When set to FULL, the MC-4 sends a full-range audio signal to this connector. Otherwise, the MC-4 activates a crossover point at the selected setting. Choose the setting closest to the low-frequency rating of the center loudspeaker. When set to NONE, the MC-4 redirects center-channel signals to the audio output connectors labeled Front L/R.

Note:

When the CENTER parameter is set to NONE, center-channel signals will not be redirected if the 5.1a BYPASS listening mode is activated. Use the associated DVD-A/SACD player to configure the speaker setup to to redirect center-channel signals.

Custom Speaker Setups (continued)

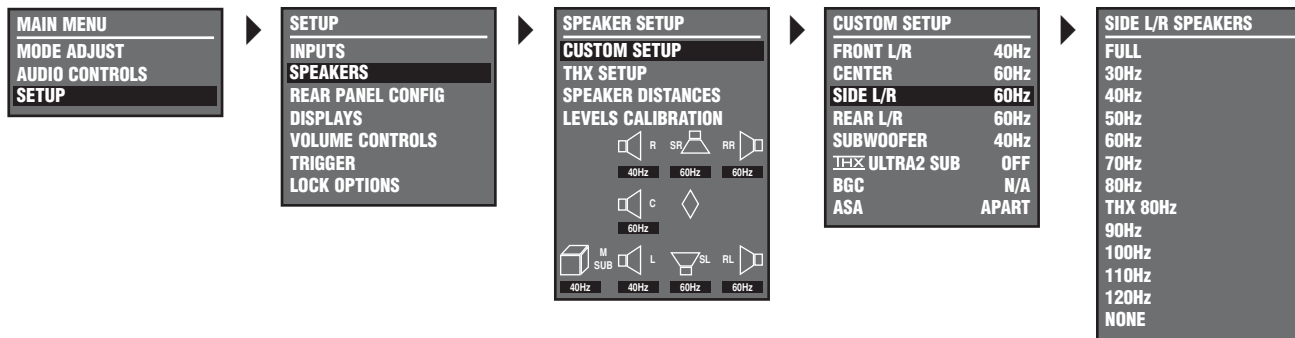

SIDE L/R FULL, 30Hz–120Hz, THX 80Hz, NONE

SETUP ▶ **SPEAKERS** ▶ **CUSTOM SETUP** ▶ **SIDE L/R**

Opens the SIDE L/R SPEAKERS menu, which can be used to select a crossover point for the audio output connectors labeled Side L/R. When set to FULL, the MC-4 sends a full-range audio signal to these connectors. Otherwise, the MC-4 activates a crossover point at the selected setting. Choose the setting closest to the low-frequency rating of the side (surround) loudspeakers.

When set to NONE, the MC-4 redirects side channel signals to the audio output connectors labeled Rear L/R. If the CUSTOM SETUP menu REAR L/R parameter is also set to NONE, the MC-4 redirects surround channel signals to the audio output connectors labeled Front L/R.

Note:

When the SIDE L/R parameter is set to NONE, Dolby Digital Surround EX, THX Ultra2, THX Surround EX and DTS-ES decoding are not available.

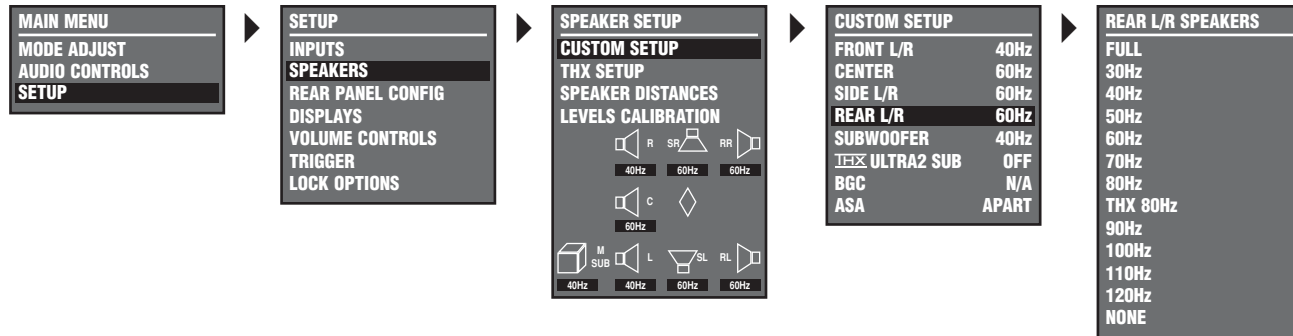

REAR L/R FULL, 30Hz–120Hz, THX 80Hz, NONE

SETUP ▶ **SPEAKERS** ▶ **CUSTOM SETUP** ▶ **REAR L/R**

Opens the REAR L/R SPEAKERS menu, which can be used to select a crossover point for the audio output connectors labeled Rear L/R. When set to FULL, the MC-4 sends a full-range audio signal to these connectors. Otherwise, the MC-4 activates a crossover point at the selected setting. Choose the setting closest to the low-frequency rating of the rear loudspeakers.

When set to NONE, the MC-4 redirects rear channel signals to the audio output connectors labeled Side L/R. If the CUSTOM SETUP menu SIDE L/R parameter is also set to NONE, the MC-4 redirects surround channel signals to the audio output connectors labeled Front L/R.

Note:

When the REAR L/R parameter is set to NONE,

- *Dolby Digital Surround EX, THX Ultra2, THX Surround EX and DTS-ES decoding are not available and*
 - *the ASA parameter is not available.*
-

Custom Speaker Setups (continued)

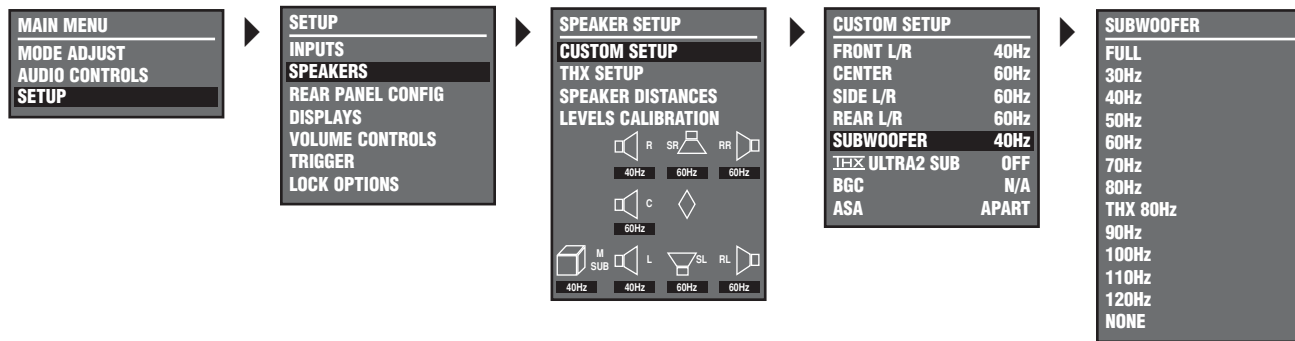

SUBWOOFER FULL, 30Hz–120Hz, THX 80Hz, NONE

SETUP ▶ **SPEAKERS** ▶ **CUSTOM SETUP** ▶ **SUBWOOFER**

Opens the SUBWOOFER menu, which can be used to select a crossover point for the audio output connector labeled Subwoofer. When set to FULL, the MC-4 sends a full-range audio signal to this connector. Otherwise, the MC-4 activates a crossover point at the selected setting. Choose the setting equal to the lowest setting of the other loudspeakers.

Note:

When the SUBWOOFER parameter is set to NONE, subwoofer signals will not be redirected if the 5.1a BYPASS listening mode is activated. Use the associated DVD-A/SACD player to configure the speaker setup to to redirect subwoofer signals.

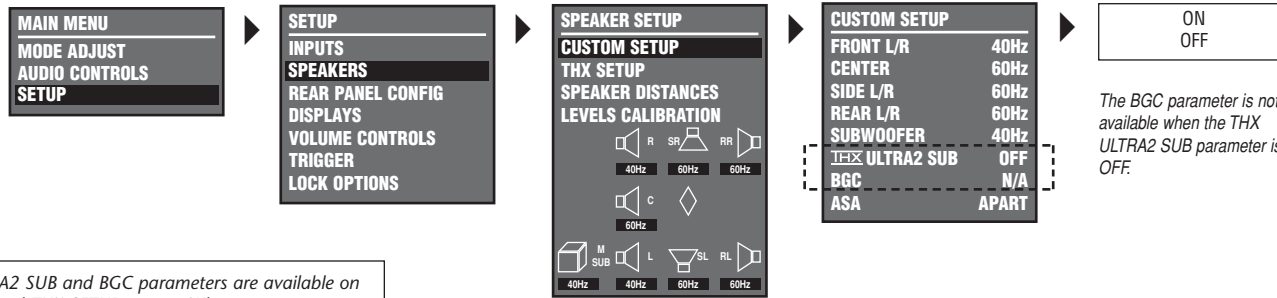

The THX ULTRA2 SUB and BGC parameters are available on the CUSTOM and THX SETUP menus. When a parameter setting is adjusted on one menu, it is automatically adjusted on the other menu as well.

The BGC parameter is not available when the THX ULTRA2 SUB parameter is OFF.

THX ULTRA2 SUB

ON, OFF

SETUP ▶ SPEAKERS ▶ CUSTOM SETUP or THX SETUP ▶ ULTRA2 SUB

Indicates whether the subwoofer connected to the audio output connector labeled Subwoofer is Ultra2 certified. Select the ON setting if the connected subwoofer is Ultra2 certified and the OFF setting if the connected subwoofer is not Ultra2 certified. When ON, the CUSTOM and THX SETUP menu BGC parameter is available to adjust boundary gain compensation. When OFF, the BGC parameter is not available.

BGC (Boundary Gain Compensation)

ON, OFF

SETUP ▶ SPEAKERS ▶ CUSTOM SETUP or THX SETUP ▶ BGC

Adjusts boundary gain compensation when the CUSTOM and THX SETUP menu THX ULTRA2 SUB parameter is ON. When the BGC parameter is ON, a high-pass 55Hz filter is applied to all listening modes and audio output connectors. When OFF, no filter is applied to listening modes and audio output connectors. When the parameter setting is N/A, the THX ULTRA2 SUB parameter is OFF and boundary gain compensation cannot be adjusted.

Note:

BGC compensates for increased bass energy that is caused by the proximity of the loudspeakers to the listening room walls.

Custom Speaker Setups (continued)

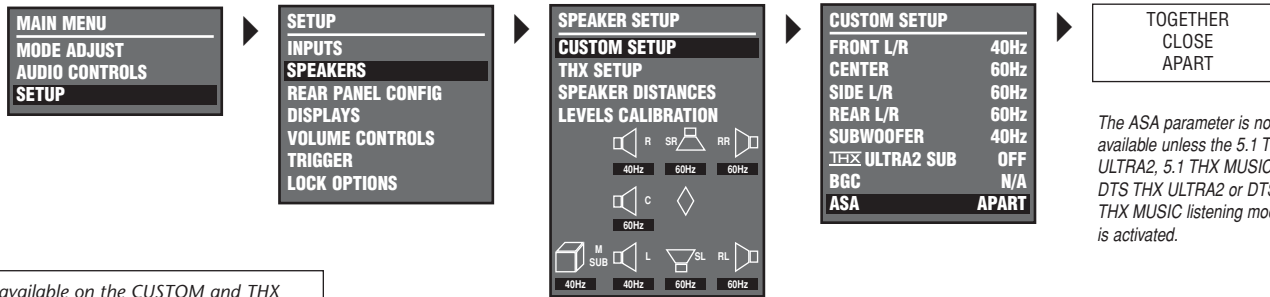

The ASA parameter is available on the CUSTOM and THX SETUP menus. When a parameter setting is adjusted on one menu, it is automatically adjusted on the other menu as well.

The ASA parameter is not available unless the 5.1 THX ULTRA2, 5.1 THX MUSIC, DTS THX ULTRA2 or DTS THX MUSIC listening mode is activated.

ASA (Advanced Speaker Array) TOGETHER, CLOSE, APART

SETUP ▶ SPEAKERS ▶ CUSTOM SETUP or THX SETUP ▶ ASA

Optimizes the listening experience for THX Ultra2 listening modes using ASA, a proprietary THX technology that processes signals sent to the rear loudspeakers. To maximize the effectiveness of ASA processing, configure a 7-channel speaker setup in which the rear speakers are placed close together facing the center of the listening space. **The ASA parameter is not available unless the THX ULTRA2, THX MUSIC, DTS THX ULTRA2 or DTS THX MUSIC listening mode is activated.**

Select the TOGETHER setting if the distance between the rear loudspeakers is less than 1 foot (0.3m). Select the CLOSE setting if the distance between the rear loudspeakers is greater than 1 foot (0.3m), but less than 4 feet (1.2m). Select the APART setting if the distance between the rear loudspeakers is greater than 4 feet (1.2m).

Note:

ASA processing is only available when both side and rear loudspeakers are present.

When the remote control 7/5 button is used to toggle between 7- and 5-channel playback,

- ASA processing is not available during 5-channel playback and
- the MC-4 automatically switches between the THX ULTRA2 and THX or DTS THX ULTRA2 and DTS THX listening modes.

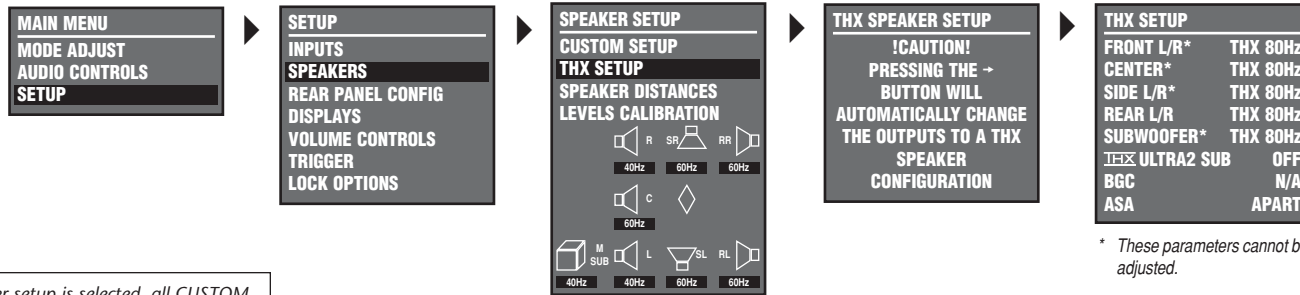

When a THX speaker setup is selected, all CUSTOM SETUP menu parameters are automatically set to THX 80Hz. However, a custom speaker setup can still be configured with the CUSTOM SETUP menu.

THX SPEAKER SETUPS

SETUP ▶ **SPEAKERS** ▶ **THX SETUP**

When the SPEAKER SETUP menu THX SETUP option is selected, the THX SPEAKER SETUP message appears on the on-screen and front panel displays. When this message appears, press the Menu ▶ arrow to open the THX SETUP menu and configure the audio output connectors for a THX speaker setup or press the Menu ◀ arrow to close the message without configuring the audio output connectors for a THX speaker setup. THX-certified loudspeakers are recommended for a THX speaker setup.

When the THX SPEAKER SETUP menu opens, the audio output connectors are automatically configured for a THX speaker setup. The MC-4 ignores all CUSTOM SETUP menu parameter settings and applies a THX 80Hz crossover point with a 12dB per-octave filter to all output connectors, except the audio output connector labeled Subwoofer, which is assigned a 24dB per-octave filter.

Note:

A THX speaker setup is not required to activate THX listening modes.

Parameter	Default Setting	Possible Setting(s)
FRONT L/R*	THX 80Hz	THX 80Hz
CENTER*	THX 80Hz	THX 80Hz
SIDE L/R*	THX 80Hz	THX 80Hz
REAR L/R	THX 80Hz	THX 80Hz, NONE
SUBWOOFER*	THX 80Hz	THX 80Hz
THX ULTRA2 SUB	OFF	ON, OFF
BGC	N/A	ON, OFF
ASA	APART	TOGETHER, CLOSE, APART

* These parameters cannot be adjusted.

THX Speaker Setups (continued)

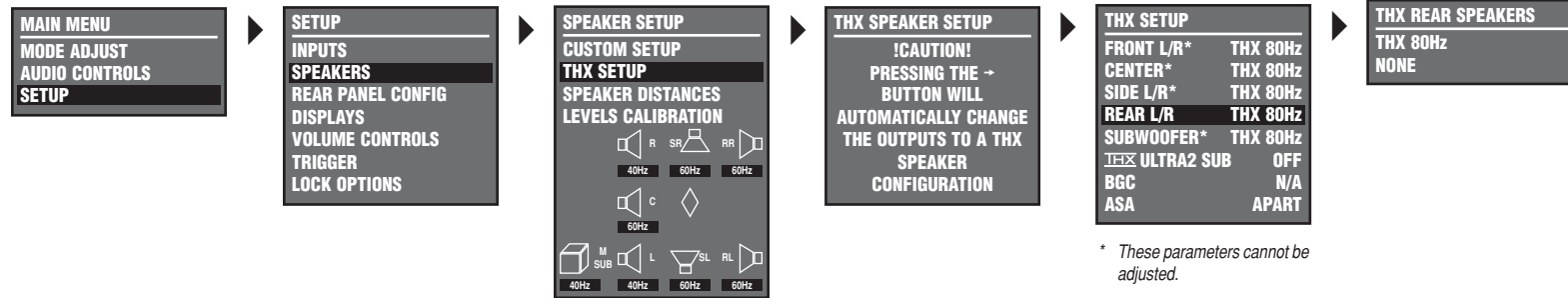

* These parameters cannot be adjusted.

REAR L/R

THX 80Hz, NONE

SETUP ▶ **SPEAKERS** ▶ **THX SETUP** ▶ **REAR L/R**

Opens the THX REAR SPEAKERS menu, which can be used to activate and deactivate the audio output connectors labeled Rear L/R. When set to THX 80Hz, the MC-4 activates these connectors and configures all audio output connectors for a 7.1-channel THX speaker setup. When set to NONE, the MC-4 deactivates these connectors and configures the other audio output connectors for a 5.1-channel THX speaker setup.

Note:

When the REAR L/R parameter is set to NONE, Dolby Digital Surround EX, THX Ultra2, THX Surround EX and DTS-ES decoding are not available, and the ASA parameter is not available.

The THX SETUP menu THX ULTRA2 SUB, BGC and ASA parameters are identical to the CUSTOM SETUP menu THX ULTRA2 SUB, BGC and ASA parameters. When one of these parameter settings is adjusted on one menu, it is automatically adjusted on the other menu at the same time. See "THX ULTRA2 SUB," "BGC" and "ASA" on page 3-31 for detailed descriptions of these parameters.

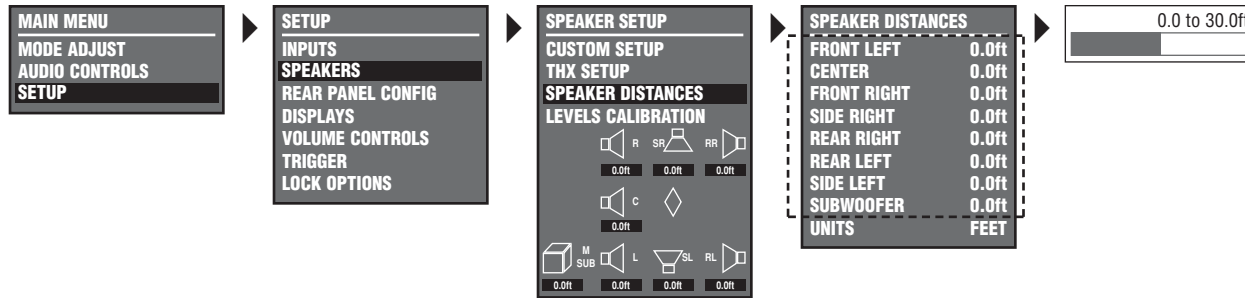

MEASURING SPEAKER DISTANCES

SETUP ▶ **SPEAKERS** ▶ **SPEAKER DISTANCES**

Selecting the SPEAKER SETUP menu SPEAKER DISTANCES option opens the SPEAKER DISTANCES menu, which can be used to set the distance between the listening position and the loudspeakers connected to the audio output connectors. The MC-4 features a speaker distance control that allows distances to be entered for each loudspeaker. This helps ensure accurate signal arrival time at the listening position, but is **not** a substitute for proper loudspeaker placement.

To determine the appropriate setting for each loudspeaker, measure the distance between the listening position and the front baffle of the loudspeaker. Then set the corresponding SPEAKER DISTANCES menu parameter to the closest available setting.

Parameter	Default Setting	Possible Settings
FRONT LEFT	0.0ft	0–30 ft or 0–12m
CENTER	0.0ft	0–30 ft or 0–12m
FRONT RIGHT	0.0ft	0–30 ft or 0–12m
SIDE RIGHT	0.0ft	0–30 ft or 0–12m
REAR RIGHT	0.0ft	0–30 ft or 0–12m
REAR LEFT	0.0ft	0–30 ft or 0–12m
SIDE LEFT	0.0ft	0–30 ft or 0–12m
SUBWOOFER	0.0ft	0–30 ft or 0–12m
UNITS	FEET	FEET, METERS

Measuring Speaker Distances (continued)

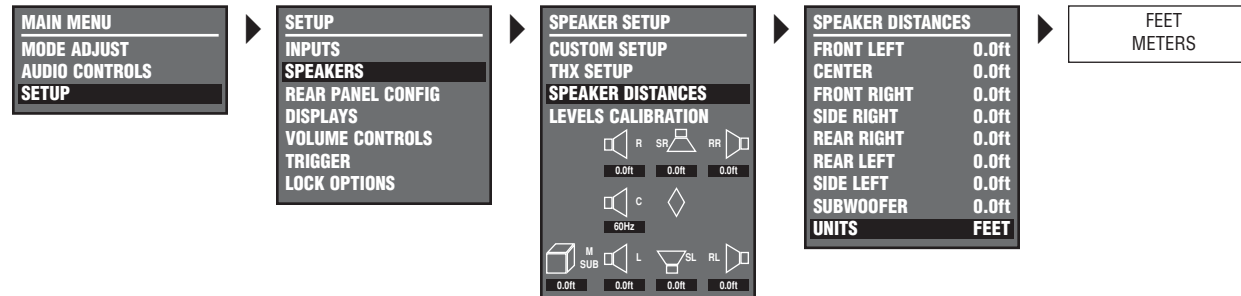

FRONT LEFT & RIGHT 0.0–30.0 ft or 0.0–12.0m

SETUP ▶ **SPEAKERS** ▶ **SPEAKER DISTANCES** ▶ **FRONT LEFT** OR **FRONT RIGHT**

Set the speaker distance for the loudspeakers connected to the audio output connectors labeled Front L/R.

REAR LEFT & RIGHT 0.0–30.0 ft or 0.0–12.0m

SETUP ▶ **SPEAKERS** ▶ **SPEAKER DISTANCES** ▶ **REAR LEFT** OR **REAR RIGHT**

Set the speaker distance for the loudspeakers connected to the audio output connectors labeled Rear L/R.

CENTER 0.0–30.0 ft or 0.0–12.0m

SETUP ▶ **SPEAKERS** ▶ **SPEAKER DISTANCES** ▶ **CENTER**

Sets the speaker distance for the loudspeaker connected to the audio output connector labeled Center.

SUBWOOFER 0.0–30.0 ft or 0.0–12.0m

SETUP ▶ **SPEAKERS** ▶ **SPEAKER DISTANCES** ▶ **SUBWOOFER**

Sets the speaker distance for the subwoofer connected to the audio output connector labeled Subwoofer.

SIDE LEFT & RIGHT 0.0–30.0 ft or 0.0–12.0m

SETUP ▶ **SPEAKERS** ▶ **SPEAKER DISTANCES** ▶ **SIDE LEFT** OR **SIDE RIGHT**

Set the speaker distance for the loudspeakers connected to the audio output connectors labeled Side L/R.

UNITS FEET, METERS

SETUP ▶ **SPEAKERS** ▶ **SPEAKER DISTANCES** ▶ **UNITS**

Defines the unit of measurement in which the MC-4 measures speaker distances. When set to FEET, the MC-4 measures speaker distances in feet. When set to METERS, the MC-4 measures speaker distances in meters. When the UNITS parameter setting is toggled, the MC-4 converts the current speaker distance to the closest available value in the new unit of measurement.

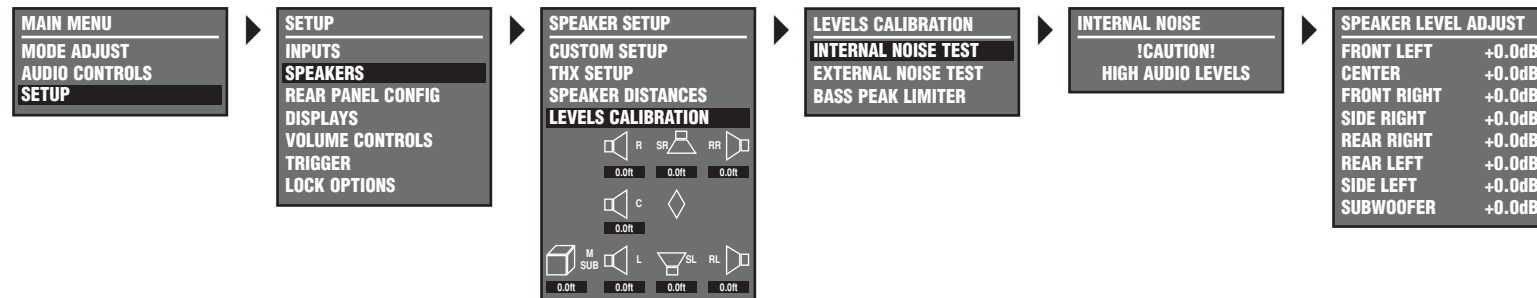

CALIBRATING OUTPUT LEVELS

SETUP ▶ **SPEAKERS** ▶ **LEVELS CALIBRATION**

Selecting the SPEAKER SETUP menu LEVELS CALIBRATION option opens the LEVELS CALIBRATION menu, which can be used to calibrate output levels for the audio output connectors. Calibration ensures that output levels correspond to THX-reference levels (75dB) for input sources such as DVDs.

Please note the following to ensure accurate output level calibration:

- Use a Sound Pressure Level (SPL) meter to calibrate output levels. An SPL meter is a device that measures the relative loudness of the loudspeakers to ensure accurate calibration.
- Before output level calibration begins, eliminate extraneous noises in the listening space, such as conversations, air conditioners and sounds that filter in through open doors and windows.

- Before output level calibration begins, remove objects and people that obstruct the line-of-sight path between the SPL meter and the loudspeaker being measured.
- Output levels should be calibrated from the primary listening position. Place the SPL meter at the approximate spot where the listener's head will be during listening.

INTERNAL NOISE TEST

SETUP ▶ **SPEAKERS** ▶ **LEVELS CALIBRATION** ▶ **INTERNAL NOISE TEST**

Opens the INTERNAL NOISE message, which indicates that the internal noise test produces loud calibration test signals. When this message appears, press the Menu ▶ arrow to open the SPEAKER LEVEL ADJUST menu and conduct the internal noise test or press the Menu ◀ arrow to close the message without conducting the internal noise test. When the SPEAKER LEVEL ADJUST menu opens, the internal noise test automatically begins.

Internal Noise Test *(continued)***Note:**

The MC-4 automatically sets volume level to +0dB when the internal noise test begins. Avoid adjusting master volume level while the test is in progress to achieve a 75dB THX-reference level (a 75dB SPL meter reading).

When the internal noise test is conducted, a calibration test signal travels to the audio output connectors in the order listed on the SPEAKER LEVEL ADJUST menu. As the calibration test signal travels, the cursor automatically scrolls downward through SPEAKER LEVEL ADJUST menu parameters, highlighting each speaker parameter as the corresponding output connector is tested. Each output connector is tested for about 4 seconds.

The SPEAKER LEVEL ADJUST menu can be used to manually adjust output levels while the internal noise test is conducted. See "SPEAKER LEVEL ADJUST" on page 3-40 for more information.

To manually adjust output levels while the internal noise test is conducted:

1. Set the SPL meter to "C" weighting and "SLOW" response.
2. Press the **Menu ▲ and ▼ arrows** to highlight the desired SPEAKER LEVEL ADJUST parameter.
3. When the desired parameter is highlighted, quickly press the **Menu ▶ arrow** to select this parameter. A horizontal bar graph will open on the on-screen display.

4. When the horizontal bar graph opens, Press the **Menu ◀ and ▶ arrows** to adjust the selected parameter. All output levels should be adjusted to achieve a 75dB SPL meter reading from the primary listening position.
5. When the desired adjustments have been made, press the **Menu ◀ arrow** to close the horizontal bar graph and return to the SPEAKER LEVEL ADJUST menu. The internal noise test will continue and automatic scrolling will resume.

Please note the following:

- When the internal noise test is conducted, it is possible to select a SPEAKER LEVEL ADJUST menu parameter just as the MC-4 is about to automatically scroll to the next parameter, causing the MC-4 to send the calibration noise to both loudspeakers. If this occurs, press the Menu ▲ and ▼ arrows to reselect the desired loudspeaker.

Note:

Audio output connectors for which the corresponding CUSTOM or THX SETUP menu parameter is set to NONE cannot be adjusted during the internal noise test. These output connectors can be adjusted during the external noise test, but there is no need to do so.

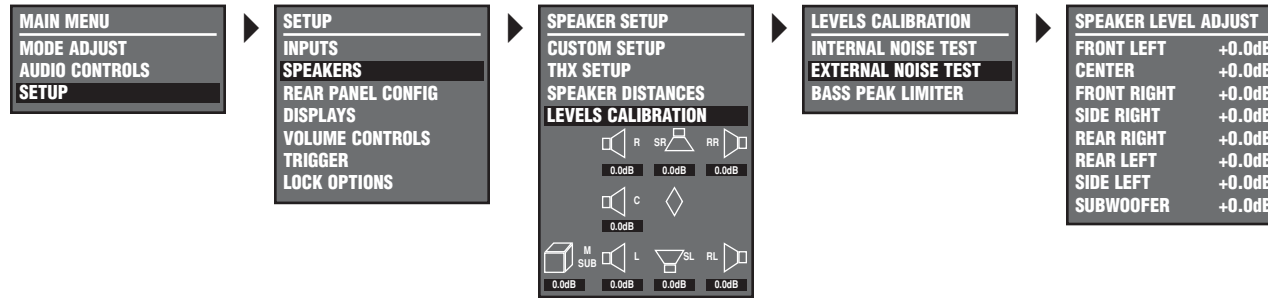

EXTERNAL NOISE TEST

SETUP ▶ **SPEAKERS** ▶ **LEVELS CALIBRATION** ▶ **EXTERNAL NOISE TEST**

Opens the SPEAKER LEVEL ADJUST menu, which can be used to adjust output levels while the external noise test is conducted. The external noise test requires an external calibration source, such as an audio calibration disc.

When the external noise test is conducted, the MC-4 activates a listening mode based on the input source that is present. The table in the next column indicates the listening mode that is activated for each input source. When a listening mode is activated during the external noise test, it retains its factory-default settings, ignoring custom settings that might have been made on the corresponding listening mode menu. Custom settings will be restored after the external noise test is complete.

2-Channel Sources	Dolby Digital Sources	DTS(-ES) Sources
DOLBY PLII MOVIE	DOLBY DIGITAL*	DTS(-ES)*

* These listening mode names differ depending on the input source, the speaker setup and certain parameter settings.

SPEAKER LEVEL ADJUST

The SPEAKER LEVEL ADJUST can be used to adjust output levels during the internal and external noise tests.

Parameter	Default Setting	Possible Settings
FRONT LEFT	0.0dB	-18.0 to +12.0dB
CENTER	0.0dB	-18.0 to +12.0dB
FRONT RIGHT	0.0dB	-18.0 to +12.0dB
SIDE RIGHT	0.0dB	-18.0 to +12.0dB
REAR RIGHT	0.0dB	-18.0 to +12.0dB
REAR LEFT	0.0dB	-18.0 to +12.0dB
SIDE LEFT	0.0dB	-18.0 to +12.0dB
SUBWOOFER	0.0dB	-18.0 to +12.0dB

FRONT LEFT & RIGHT -18.0dB to +12.0dB

SETUP ▶ **SPEAKERS** ▶ **LEVELS CALIBRATION** ▶ **(TEST)** ▶ **FRONT LEFT OR FRONT RIGHT**

Set the output levels for the loudspeakers connected to the audio output connectors labeled Front L/R.

CENTER -18.0dB to +12.0dB

SETUP ▶ **SPEAKERS** ▶ **LEVELS CALIBRATION** ▶ **(TEST)** ▶ **CENTER**

Sets the output level for the loudspeaker connected to the audio output connector labeled Center.

SIDE LEFT & RIGHT -18.0dB to +12.0dB

SETUP ▶ **SPEAKERS** ▶ **LEVELS CALIBRATION** ▶ **(TEST)** ▶ **SIDE LEFT OR SIDE RIGHT**

Set the output levels for the loudspeakers connected to the audio output connectors labeled Side L/R.

REAR LEFT & RIGHT -18.0dB to +12.0dB

SETUP ▶ **SPEAKERS** ▶ **LEVELS CALIBRATION** ▶ **(TEST)** ▶ **REAR LEFT OR REAR RIGHT**

Set the output levels for the loudspeakers connected to the audio output connectors labeled Rear L/R.

SUBWOOFER -18.0dB to +12.0dB

SETUP ▶ **SPEAKERS** ▶ **LEVELS CALIBRATION** ▶ **(TEST)** ▶ **SUBWOOFER**

Sets the output level for the subwoofer connected to the audio output connector labeled Subwoofer.

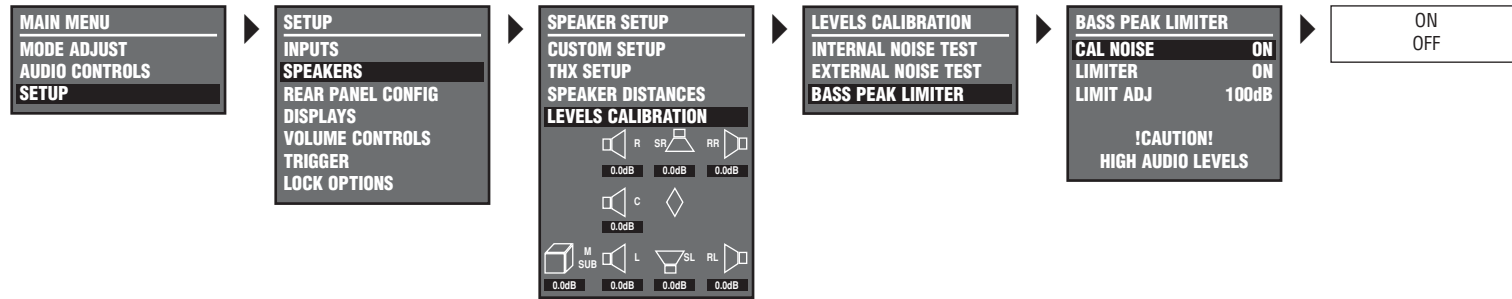

BASS PEAK LIMITER

SETUP ▶ **SPEAKERS** ▶ **LEVELS CALIBRATION** ▶ **BASS PEAK LIMITER**

Opens the BASS PEAK LIMITER menu, which can be used to set amplitude limits for all loudspeakers to which low frequencies are redirected, including the subwoofer.

The MC-4 is equipped with an internal limiter that prevents low-frequency output signals from exceeding designated levels. This is essential for Dolby Digital and DTS(-ES) input sources that produce low-frequency peaks at much higher levels than 2-channel sources. In home theaters, the subwoofer and its associated amplifier might not be able to reproduce these levels without overloading.

Parameter	Default Setting	Possible Settings
CAL NOISE	ON	ON, OFF
LIMITER	ON	ON, OFF
LIMIT ADJ	100dB	75dB to 120dB

CAL NOISE

ON, OFF

SETUP ▶ **SPEAKERS** ▶ **LEVELS CALIBRATION** ▶ **BASS PEAK LIMITER** ▶ **CAL NOISE**

Determines whether the bass peak limiter is set with an internal or external source. When ON, the MC-4 activates an internal calibration noise signal to set the limiter. When OFF, the MC-4 deactivates the internal calibration noise test signal. An external calibration source such as an audio calibration disc is required to generate a noise signal to set the bass peak limiter.

BASS PEAK LIMITER (continued)

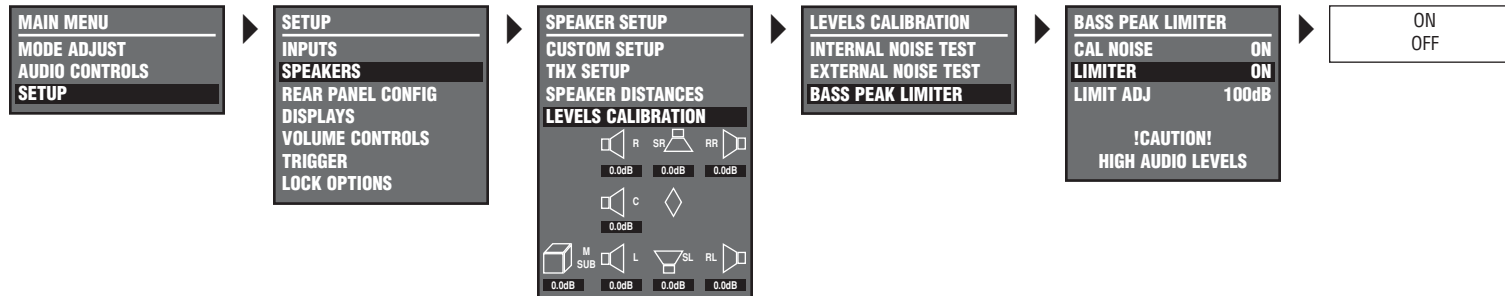

LIMITER

ON, OFF



Limits output signals for the audio output connector labeled Subwoofer, as well as other audio output connectors to which low-frequency signals are redirected. When ON, the MC-4 restricts output signals to the level specified with the BASS PEAK LIMITER menu LIMIT ADJ parameter. When OFF, the MC-4 does not restrict output levels, regardless of the LIMIT ADJ parameter setting.

LIMIT ADJ

75dB to 120dB



Specifies the output level restriction placed on the audio output connector labeled Subwoofer, as well as other audio output connectors to which low-frequency signals are redirected. This restriction is applied when the BASS PEAK LIMITER menu LIMITER parameter is ON. When the LIMIT ADJ parameter is selected, it is automatically set to 75dB.

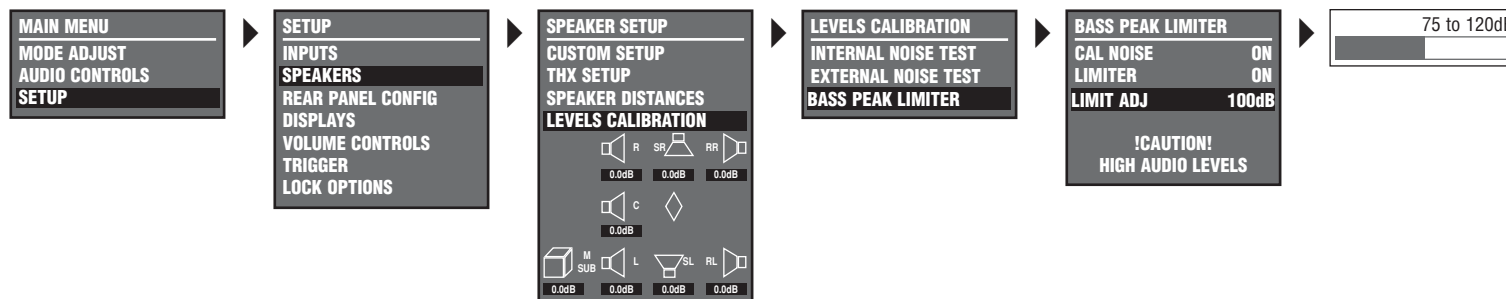

REAR PANEL CONFIG

SETUP ▶ REAR PANEL CONFIG

Selecting the SETUP menu REAR PANEL CONFIG option opens the REAR PANEL CONFIG menu, which can be used to configure the analog audio input connectors as eight stereo connectors, one 5.1-channel and five stereo connectors or two 5.1-channel and two stereo connectors.

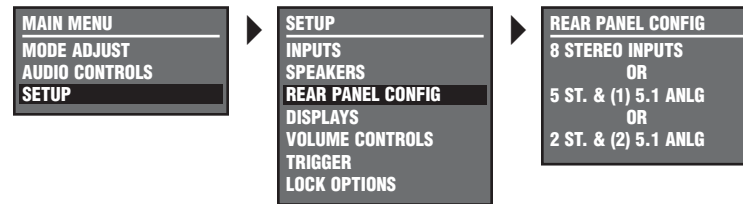

8 STEREO INPUTS

SETUP ▶ REAR PANEL CONFIG ▶ 8 STEREO INPUTS

Configures the analog audio input connectors as eight stereo connectors (the factory-default configuration).

When the analog audio input connectors are configured as eight stereo connectors:

- All connectors are configured as stereo connectors.
- Neither of the 5.1-channel connectors is available. Sources that were assigned to the 5.1-channel connectors are reassigned to the corresponding stereo connectors.

5 ST. & (1) 5.1 ANLG

SETUP ▶ REAR PANEL CONFIG ▶ 5 ST. & (1) 5.1 ANLG

Configures the analog audio input connectors as one 5.1-channel and five stereo connectors.

When the analog audio input connectors are configured as five stereo and one 5.1-channel connectors:

- The connectors labeled 1, 2, 3, 4 and 5 are configured as stereo connectors.
- The connectors labeled 6, 7 and 8 are configured as a 5.1-channel connector. This connector is sent to the audio output connectors as indicated in the table on the next page.

5 ST. & (1) 5.1 ANLG *(continued)*

SETUP ▶ **REAR PANEL CONFIG** ▶ **5 ST. & (1) 5.1 ANLG**

When the analog audio input connectors are configured as five stereo and one 5.1-channel connectors:

- Two-channel sources that were assigned to the stereo connectors are reassigned to the corresponding 5.1-channel connectors. The 5.1-channel connectors should only be used with 5.1-channel analog sources such as DVD-As and SACDs.

2 ST. & (2) 5.1 ANLG

SETUP ▶ **REAR PANEL CONFIG** ▶ **2 ST. & (2) 5.1 ANLG**

Configures the analog audio input connectors as two stereo and two 5.1-channel connectors.

When the analog audio input connectors are configured as two stereo and two 5.1-channel connectors:

- The connectors labeled 1 and 2 are configured as stereo connectors.
- The connectors labeled 3, 4 and 5 are configured as a 5.1-channel connector and the connectors labeled 6, 7 and 8 are configured as a 5.1-channel connector. These connectors are sent to the audio output connectors as indicated in the table in the next column.
- Two-channel sources that were assigned to the stereo connectors are reassigned to the corresponding 5.1-channel connectors. The 5.1-channel connectors should only be used with 5.1-channel analog sources such as DVD-As and SACDs.

The 5.1-channel analog audio input connector is sent to the analog audio output connectors as shown in the table below.

Input Connector	Output Connector
(L)	Front L
(R)	Front R
(C)	Center
(SUB)	Subwoofer
(LS)	Side L and Rear L
(RS)	Side R and Rear R

DISPLAY SETUP

SETUP ▶ **DISPLAYS**

Selecting the SETUP menu DISPLAYS option opens the DISPLAY SETUP menu, which can be used to customize the on-screen and front panel displays, restore audio/video synchronization and activate and create a custom unit name.

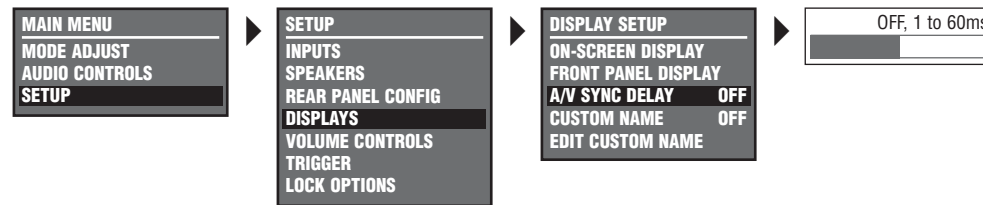

Parameter	Default Setting	Possible Settings
ON-SCREEN DISPLAY	See "ON-SCREEN DISPLAY Setup" on page 3-47 for more information.	
FRONT PANEL DISPLAY	See "FRONT PANEL DISPLAY Setup" on page 3-50 for more information.	
A/V SYNC DELAY	OFF	OFF, 1ms–60ms
CUSTOM NAME	OFF	ON, OFF
EDIT CUSTOM NAME	N/A	N/A

A/V SYNC DELAY

OFF, 1–60ms

SETUP ▶ **DISPLAYS** ▶ **A/V SYNC DELAY**

Restores audio/video synchronization when using products such as video processors that introduce a video signal delay. This parameter sets an audio signal delay to compensate for the video signal delay.

DISPLAY SETUP (continued)

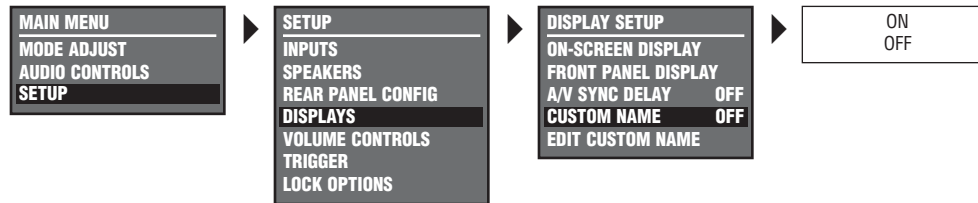

CUSTOM NAME

ON, OFF

SETUP ▶ **DISPLAYS** ▶ **CUSTOM NAME**

Activates the custom unit name, which displays when the MC-4 is activated. When ON, the custom name scrolls across the on-screen and front panel displays when the MC-4 is activated. When OFF, the custom name does not display when the MC-4 is activated. The custom name can be entered in the DISPLAY SETUP menu EDIT CUSTOM NAME parameter.

EDIT CUSTOM NAME

SETUP ▶ **DISPLAYS** ▶ **EDIT CUSTOM NAME**

Opens the EDIT CUSTOM NAME drop-down menu, which can be used to create or edit a custom unit name.

To customize the name of the MC-4:

1. Follow the EDIT CUSTOM NAME menu path to open the EDIT CUSTOM NAME drop-down menu.
2. Press the remote control **Menu** ▲ and ▼ arrows to change the character above the cursor (^).
3. When the desired character has been selected, press the **Menu** ▶ arrow to advance to the next character space. Press the **Menu** ◀ arrow to return to the previous character space. The cursor will automatically wrap to the first character space when the last character space is passed.
4. Repeat steps 2 and 3 to enter the desired custom unit name.
5. When the desired custom unit name has been entered, press the **Menu** ◀ arrow to close the EDIT CUSTOM NAME drop-down menu and return to the DISPLAY SETUP menu.

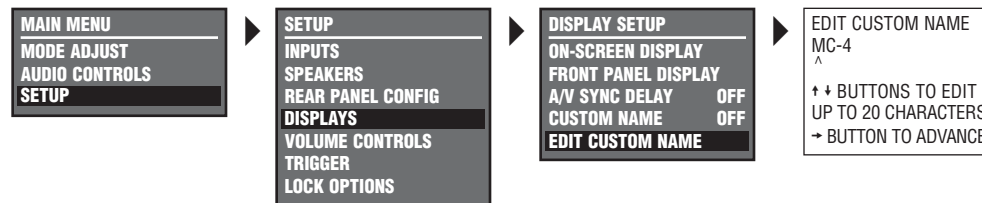

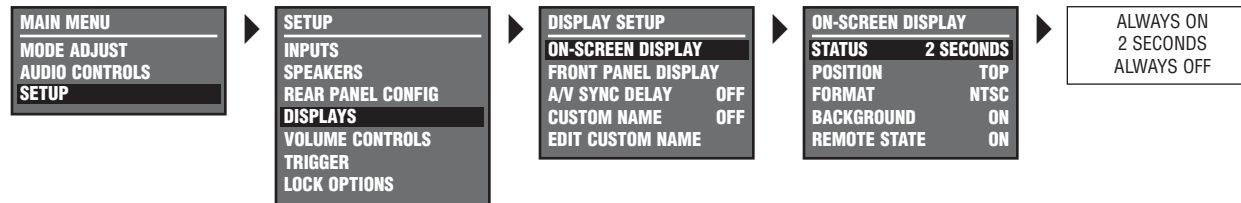

ON-SCREEN DISPLAY SETUP

SETUP ▶ **DISPLAYS** ▶ **ON-SCREEN DISPLAY**

The ON-SCREEN DISPLAY menu can be used to customize the on-screen display.

Parameter	Default Setting	Possible Settings
STATUS	2 SECONDS	ALWAYS ON, 2 SECONDS, ALWAYS OFF
POSITION	TOP	TOP, CENTER, BOTTOM
FORMAT	NTSC	SECAM, PAL, NTSC
BACKGROUND	ON	ON, OFF
REMOTE STATE	ON	ON, OFF

STATUS

ALWAYS ON, 2 SECONDS, ALWAYS OFF

SETUP ▶ **DISPLAYS** ▶ **ON-SCREEN DISPLAY** ▶ **STATUS**

Activates and deactivates the on-screen display sent to the video output connector. When ALWAYS ON, the on-screen display remains on at all times. When set to 2 SECONDS, the on-screen display appears for 2 seconds whenever the input source changes or the MC-4 receives a command. When ALWAYS OFF, the on-screen display remains off at all times. It will not display again until the ON-SCREEN DISPLAY menu STATUS parameter is set to ALWAYS ON or 2 SECONDS.

Note:

When the ON-SCREEN DISPLAY menu STATUS parameter is ALWAYS OFF, the on-screen display immediately disappears. Press the remote control OSD button or use the front panel display as a guide to reset the parameter to ALWAYS ON or 2 SECONDS.

On-Screen Display Setup *(continued)*

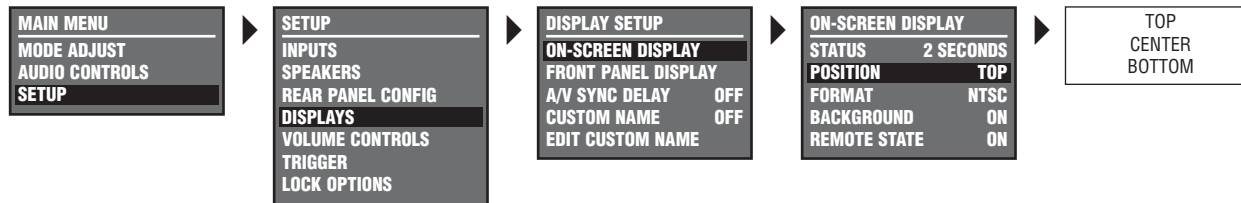

POSITION

TOP, CENTER, BOTTOM

SETUP ▶ DISPLAYS ▶ ON-SCREEN DISPLAY ▶ POSITION

Controls the vertical position of the two-line status on the display device screen. When set to TOP, the two-line status displays near the top of the display device screen. When set to CENTER, the two-line status is centered on the display device screen. When set to BOTTOM, the two-line status displays near the bottom of the display device screen. See “Two-Line Status” on page 2-14 for more information.

FORMAT

SECAM, PAL, NTSC

SETUP ▶ DISPLAYS ▶ ON-SCREEN DISPLAY ▶ FORMAT

Controls the compatibility among the video input connectors, the video switcher and the display device. Select the setting that is compatible with the source components and display device.

Note:

The FORMAT parameter affects the composite and S-video output connectors. It does not affect the component video output connector.

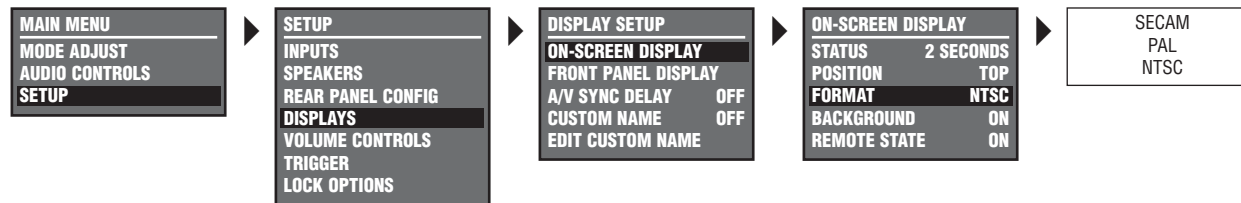

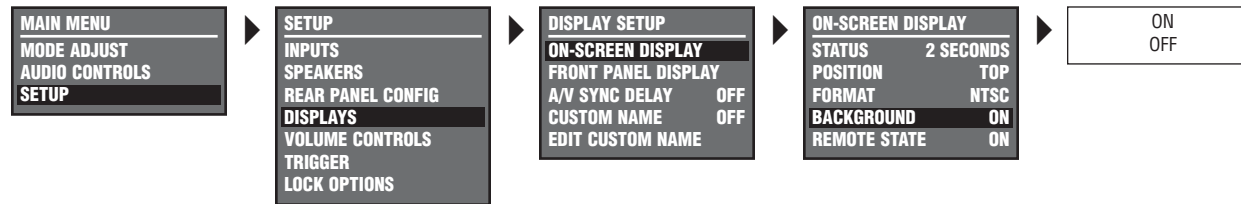
**BACKGROUND**

ON, OFF

SETUP ▶ **DISPLAYS** ▶ **ON-SCREEN DISPLAY** ▶ **BACKGROUND**

Activates and deactivates the menu background. When ON, on-screen display menus appear over a solid blue or gray background (depending on the display device). When OFF, on-screen display menus appear over the video input signal.

Note:

When the BACKGROUND parameter is OFF, the on-screen display will disappear if the display device is using the component video output connector.

REMOTE STATE

ON, OFF

SETUP ▶ **DISPLAYS** ▶ **ON-SCREEN DISPLAY** ▶ **REMOTE STATE**

Controls the remote control command bank indicator that displays on the on-screen display. When ON, a command bank indicator appears in the top-right corner of the on-screen display to indicate the last command bank from which the MC-4 received a command. When OFF, no command bank indicator appears on the on-screen display.

An S2 appears when a command from the Shift 2 command bank was received last. An S appears when a command from the Shift 1 command bank was received last. No character appears when a command from the default command bank was received last.

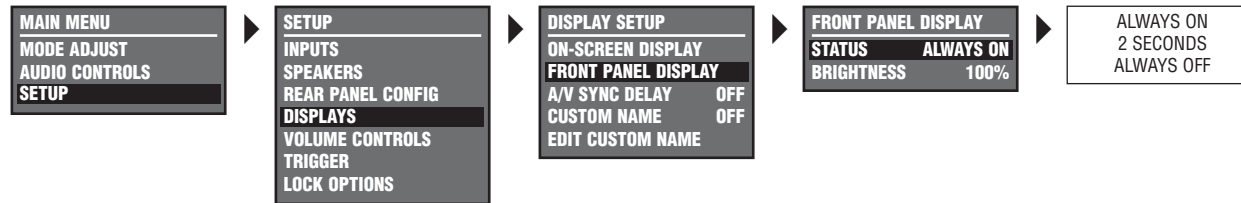

FRONT PANEL DISPLAY SETUP

SETUP ▶ **DISPLAYS** ▶ **FRONT PANEL DISPLAY**

The FRONT PANEL DISPLAY menu can be used to customize the front panel display.

Parameter	Default Setting	Possible Settings
STATUS	ALWAYS ON	ALWAYS ON, 2 SECONDS, ALWAYS OFF
BRIGHTNESS	100%	100%, 75%, 50%, 25%

STATUS ALWAYS ON, 2 SECONDS, ALWAYS OFF

SETUP ▶ **DISPLAYS** ▶ **FRONT PANEL DISPLAY** ▶ **STATUS**

Activates and deactivates the front panel display. When ALWAYS ON, the front panel display remains on at all times. When set to 2 SECONDS, the front panel display appears for 2 seconds whenever the input source changes or the MC-4 receives a command. When ALWAYS OFF, the front panel display remains off at all times.

Note:

When the FRONT PANEL DISPLAY menu STATUS parameter is ALWAYS OFF, the front panel display immediately disappears. Press the remote control FP button or use the on-screen display as a guide to reset the parameter to ALWAYS ON or 2 SECONDS.

BRIGHTNESS 100%, 75%, 50%, 25%

SETUP ▶ **DISPLAYS** ▶ **FRONT PANEL DISPLAY** ▶ **BRIGHTNESS**

Controls the brightness of front panel display characters. When a setting is selected, front panel display illumination automatically adjusts to the selected percentage.

VOLUME CONTROL SETUP

SETUP ▶ **VOLUME CONTROLS**

Selecting the SETUP menu VOLUME CONTROLS option opens the VOLUME CONTROL SETUP menu, which can be used to configure volume and mute levels.

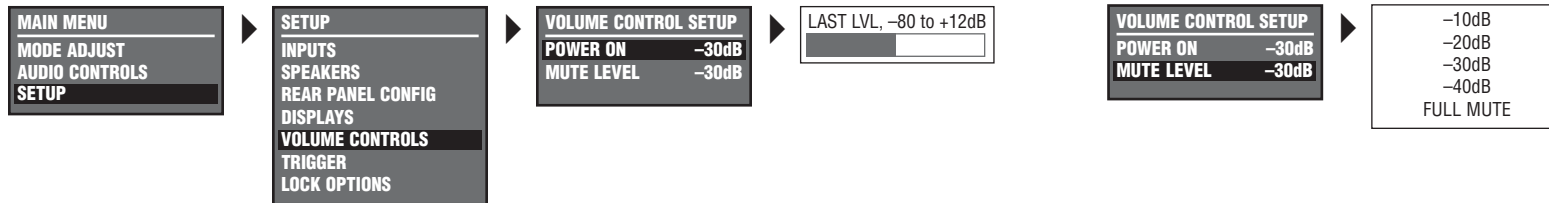

Parameter	Default Setting	Possible Settings
POWER ON	-30dB	LAST LVL, -80dB to +12dB
MUTE LEVEL	-30dB	FULL, -40dB, -30dB, -20dB, -10dB

POWER ON LAST LVL, -80dB to +12dB

SETUP ▶ **VOLUME CONTROLS** ▶ **POWER ON**

Sets the volume level that will be selected whenever the MC-4 is activated. When set to LAST LVL, the MC-4 will activate at the last volume level that was selected during the previous operating session.

MUTE LEVEL FULL, -40dB, -30dB, -20dB, -10dB

SETUP ▶ **VOLUME CONTROLS** ▶ **MUTE LEVEL**

Sets the amount of attenuation that occurs whenever the mute button is pressed. When set to FULL, volume level will be fully attenuated whenever the mute button is pressed. Otherwise, volume level will be attenuated to the selected level.

TRIGGER SETUP

SETUP ▶ TRIGGER

Selecting the SETUP menu TRIGGER option opens the TRIGGER SETUP menu, which can be used to configure the trigger output connector labeled 1. The MC-4 rear panel includes two 12V DC trigger output connectors. The connector labeled PWR—the power trigger output connector—is not configurable. It is activated when the MC-4 is activated and deactivated when the MC-4 is deactivated. The connector labeled 1 can be configured for remote or program operation.

Parameter	Default Setting	Possible Settings
REMOTE ONLY	ON	ON, OFF
Program Operation	OFF	ON, OFF

All TRIGGER SETUP menu parameters—except the REMOTE ONLY parameter—are considered program operation parameters.

REMOTE ONLY

ON, OFF

SETUP ▶ TRIGGER ▶ REMOTE ONLY

Configures the trigger output connector labeled 1 for remote operation. When ON, the trigger output connector labeled 1 is configured for remote operation. Pressing and holding the S1 button while pressing and releasing the Mode ▲ and ▼ buttons activates and deactivates the connector. The MC-4 ignores all other TRIGGER SETUP menu parameter settings. When OFF, the trigger output connector labeled 1 is not configured for remote operation. It can be configured for program operation.

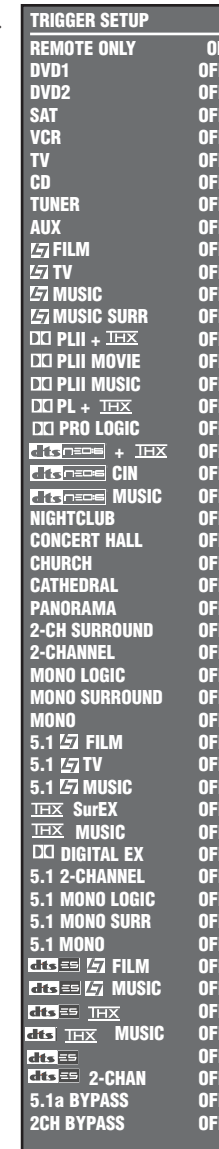
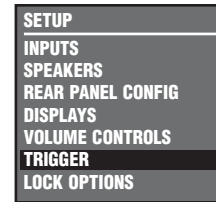

* TRIGGER SETUP menu listening mode names are fixed, meaning these names do not change when certain encoding is present. For instance, the 5.1 THX SurEX listening mode label appears whether THX Ultra2, THX Surround EX or no encoding is present.

Program Operation Parameters ON, OFF

SETUP ▶ TRIGGER ▶ (PROGRAM OPERATION PARAMETER)

Configure the trigger output connector labeled 1 for program operation. All TRIGGER SETUP menu parameters—except the REMOTE ONLY parameter—are considered program operation parameters. These parameters can be used to associate the trigger output connector with multiple inputs and listening modes at the same time.

When the REMOTE ONLY parameter is OFF and program operation parameters are ON, the trigger output connector labeled 1 is associated with the corresponding inputs and listening modes. When configured for program operation, the connector is activated whenever the corresponding inputs and listening modes are selected and deactivated whenever the corresponding inputs and listening modes are deselected.

Note:

When the factory-default version of the selected listening mode is restored, the corresponding TRIGGER SETUP menu listening mode parameter is automatically OFF.

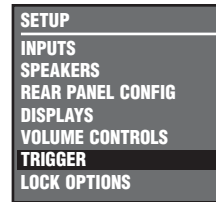

TRIGGER SETUP	
REMOTE ONLY	ON
DVD1	OFF
DVD2	OFF
SAT	OFF
VCR	OFF
TV	OFF
CD	OFF
TUNER	OFF
AUX	OFF
FILM	OFF
TV	OFF
MUSIC	OFF
MUSIC SURR	OFF
PLII + THX	OFF
PLII MOVIE	OFF
PLII MUSIC	OFF
PL + THX	OFF
PRO LOGIC	OFF
THX + THX	OFF
CIN	OFF
MUSIC	OFF
NIGHTCLUB	OFF
CONCERT HALL	OFF
CHURCH	OFF
CATHEDRAL	OFF
PANORAMA	OFF
2-CH SURROUND	OFF
2-CHANNEL	OFF
MONO LOGIC	OFF
MONO SURROUND	OFF
MONO	OFF
5.1 FILM	OFF
5.1 TV	OFF
5.1 MUSIC	OFF
THX SurEX	OFF
THX MUSIC	OFF
DIGITAL EX	OFF
5.1 2-CHANNEL	OFF
5.1 MONO LOGIC	OFF
5.1 MONO SURR	OFF
5.1 MONO	OFF
5.1 FILM	OFF
5.1 MUSIC	OFF
THX	OFF
THX MUSIC	OFF
2-CHAN	OFF
5.1a BYPASS	OFF
2CH BYPASS	OFF

ON
OFF

* TRIGGER SETUP menu listening mode names are fixed, meaning these names do not change when certain encoding is present. For instance, the 5.1 THX SurEX listening mode label appears whether THX Ultra2, THX Surround EX, or no encoding is present.

LOCK OPTIONS

SETUP ▶ **LOCK OPTIONS**

Selecting the SETUP menu LOCK OPTIONS option opens the LOCK OPTIONS menu, which can be used to lock and unlock settings in the MODE ADJUST, AUDIO CONTROLS and SETUP menu branches.

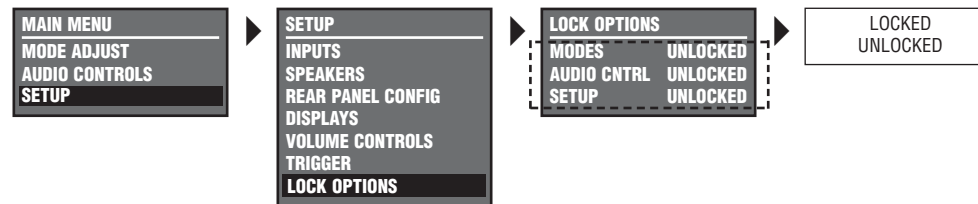

Parameter	Default Setting	Possible Settings
MODES	UNLOCKED	LOCKED, UNLOCKED
AUDIO CNTRL	UNLOCKED	LOCKED, UNLOCKED
SETUP	UNLOCKED	LOCKED, UNLOCKED

MODES

LOCKED, UNLOCKED

SETUP ▶ **LOCK OPTIONS** ▶ **MODES**

Controls MODE ADJUST menu branch settings, which includes all listening mode menu settings. When LOCKED, these settings cannot be adjusted. When UNLOCKED, these settings can be adjusted.

AUDIO CNTRL

LOCKED, UNLOCKED

SETUP ▶ **LOCK OPTIONS** ▶ **AUDIO CNTRL**

Controls AUDIO CONTROLS menu branch settings. When LOCKED, these settings cannot be adjusted. When UNLOCKED, these settings can be adjusted.

SETUP

LOCKED, UNLOCKED

SETUP ▶ **LOCK OPTIONS** ▶ **SETUP**

Controls SETUP menu branch settings. When LOCKED, these settings cannot be adjusted. When UNLOCKED, these settings can be adjusted.

4

AUDIO CONTROLS

AUDIO CONTROLS 4-2

AUDIO CONTROLS

Selecting the MAIN MENU AUDIO CONTROLS option opens the AUDIO CONTROLS menu, which can be used to customize the audio output connectors. These parameter settings affect all inputs and listening modes selected, except the 5.1a BYPASS and 2CH BYPASS listening modes.

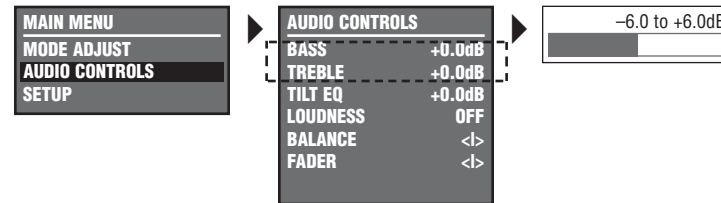

Default Parameter	Possible Value	Settings
BASS	+0.0dB	-6.0dB to +6.0dB
TREBLE	+0.0dB	-6.0dB to +6.0dB
TILT EQ	+0.0dB	-3.0dB to +3.0dB
LOUDNESS	OFF	ON, OFF
BALANCE	< >	L< to < > to >R
FADER	< >	B< to < > to >F

AUDIO CONTROLS menu parameter descriptions begin in the next column.

Note:

Pressing and holding the S2 button while pressing and releasing the Blue button sets the BASS, TREBLE and TILT EQ parameters to +0.0dB.

BASS

-6.0dB to +6.0dB

AUDIO CONTROLS ▶ BASS

Controls the amount of low-frequency boost or cut applied to the audio output connectors labeled Front L/R, Center and Subwoofer. The graph shown on the left of the next page illustrates the frequency response of BASS parameter settings.

TREBLE

-6.0dB to +6.0dB

AUDIO CONTROLS ▶ TREBLE

Controls the amount of boost or cut applied to the audio output connectors labeled Front L/R and Center. The graph shown on the left of the next page illustrates the frequency response of TREBLE parameter settings.

BASS Parameter Settings

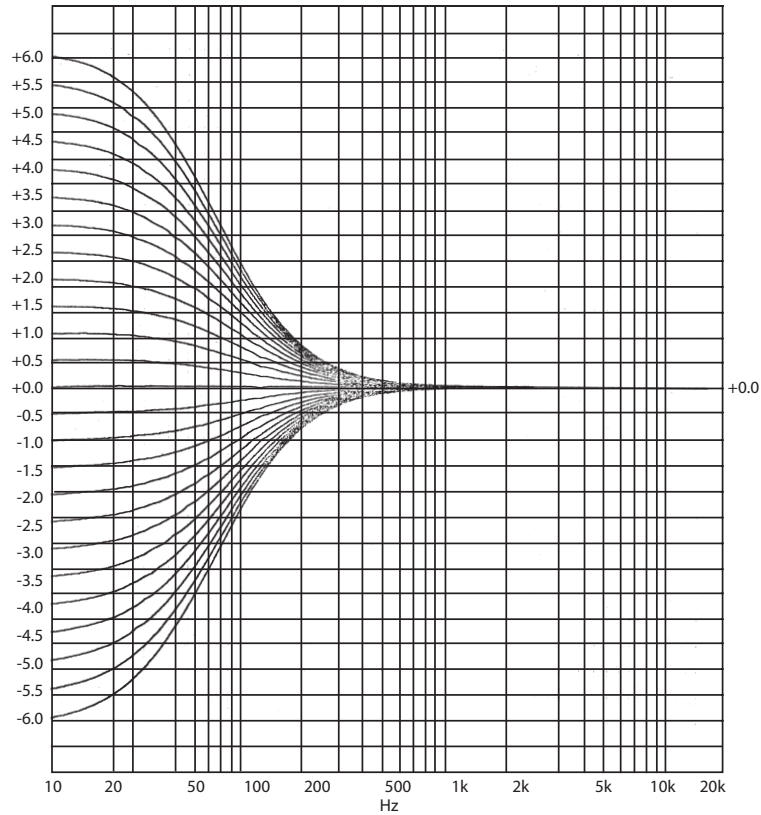

The BASS parameter controls the amount of low-frequency boost or cut applied to the audio output connectors labeled Front L/R, Center and Subwoofer.

TREBLE Parameter Settings

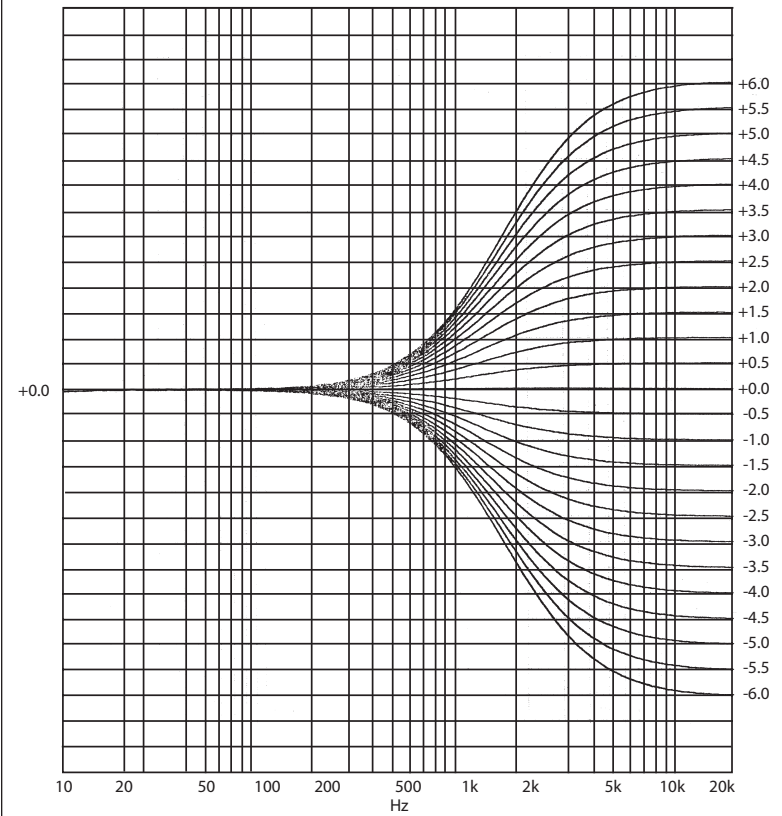

The TREBLE parameter controls the amount of boost or cut applied to the audio output connectors labeled Front L/R and Center.

AUDIO CONTROLS (continued)

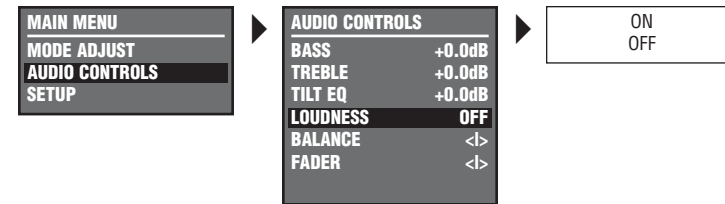
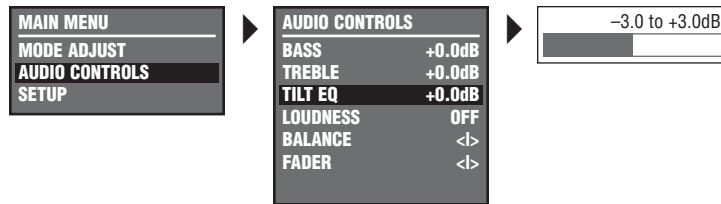

TILT EQ

-3.0dB to +3.0dB

AUDIO CONTROLS ▶ TILT EQ

Controls the amount of tilt equalization applied to the audio output connectors labeled Front L/R, Center and Subwoofer. This parameter setting affects the entire frequency spectrum with a hinge point at 1kHz. As the setting is increased, frequencies higher than 1kHz are boosted, while frequencies lower than 1kHz are simultaneously cut. As the setting is decreased, frequencies higher than 1kHz are cut, while frequencies lower than 1kHz are simultaneously boosted. The graph on the next page illustrates the frequency response of TILT EQ parameter settings.

Note:

Pressing and holding the S2 button while pressing and releasing the Blue button sets the BASS, TREBLE and TILT EQ parameters to +0.0dB.

LOUDNESS

ON, OFF

AUDIO CONTROLS ▶ LOUDNESS

Controls the amount of low-frequency boost that is automatically applied to the audio output connectors labeled Front L/R, Center and Subwoofer. When set to ON, loudness compensation is automatically applied based on volume level. As volume level increases, the amount of boost automatically decreases. The loudness contour is optimized for sources calibrated to THX-reference levels. When set to OFF, no loudness compensation is applied. The graph on the next page illustrates the frequency response that is automatically applied when the LOUDNESS parameter is set to ON and volume level is adjusted.

Note:

The graph on the next page displays LOUDNESS parameter settings between -30dB and 0dB in 1dB increments. The top-most line represents the curve at -30dB.

TILT EQ Parameter Settings

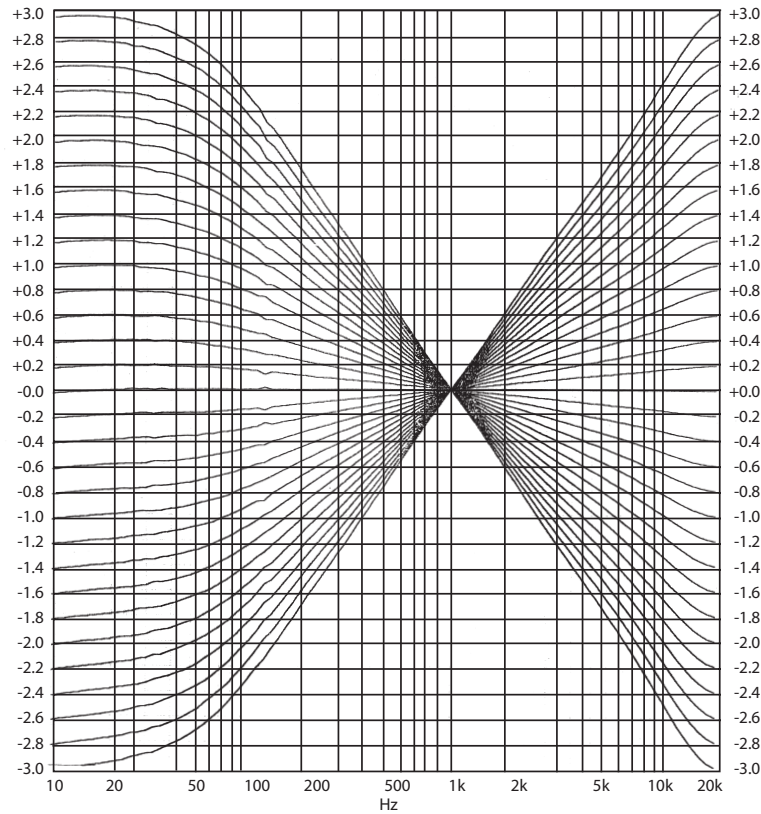

The TILT EQ parameter controls the amount of tilt equalization applied to the audio output connectors labeled Front L/R, Center and Subwoofer.

LOUDNESS Parameter Settings

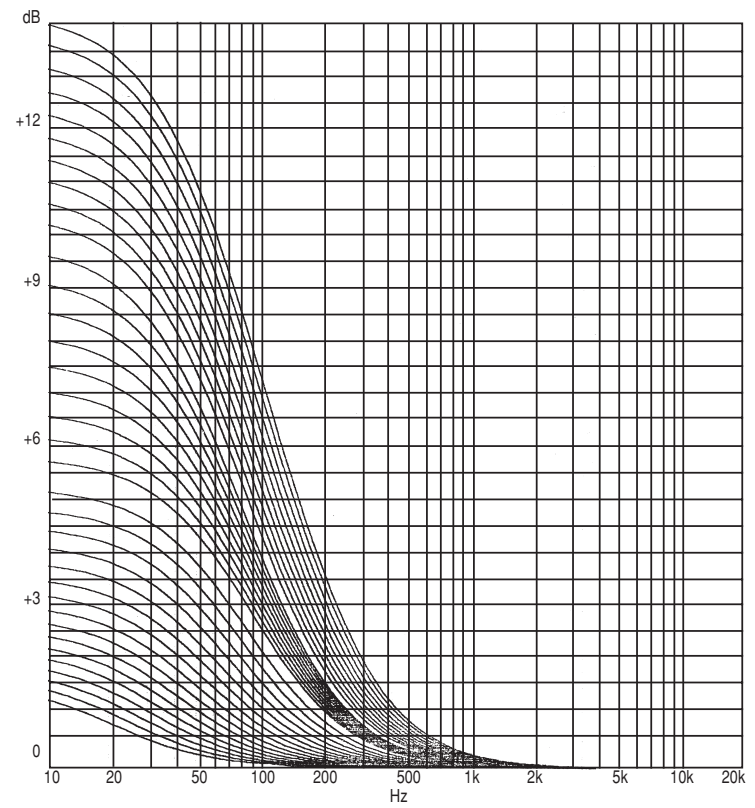

The LOUDNESS parameter controls the amount of low-frequency boost that is automatically applied to the audio output connectors labeled Front L/R, Center and Subwoofer.

AUDIO CONTROLS (continued)

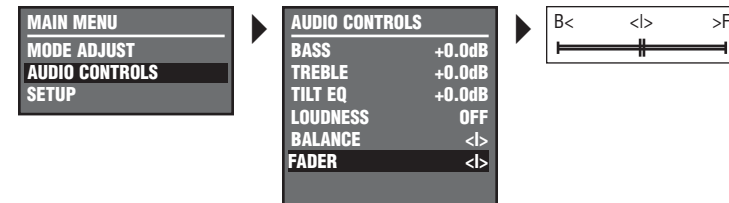
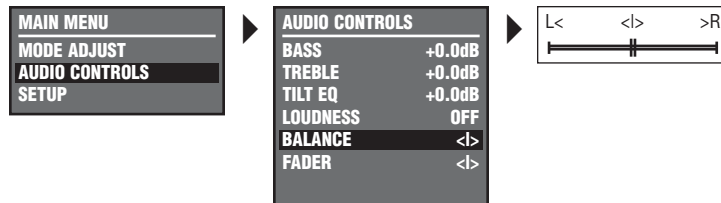

BALANCE

L< to <|> to >R

AUDIO CONTROLS ▶ **BALANCE**

Controls the left-to-right balance of the audio output connectors.

FADER

B< to <|> to >F

AUDIO CONTROLS ▶ **FADER**

Controls the back-to-front balance of the audio output connectors.

Note:

Pressing and holding the S1 button while pressing and releasing the FP button centers the BALANCE and FADER parameters.

5

MODE ADJUST

MODE ADJUST.	5-2
Listening Mode Activation	5-2
<i>Preferred Listening Mode Selection Parameters • Mode ▲ and ▼ Buttons • Mode Family Selection Buttons</i>	
Listening Mode Descriptions.	5-4
<i>5.1 FILM • 5.1 TV • 5.1 MUSIC • 5.1 MUSIC SURR • DOLBY II + THX • DOLBY II MOVIE • DOLBY II MUSIC • DOLBY PRO LOGIC • DOLBY PL + THX • DTS CIN • DTS + THX • DTS MUSIC • NIGHTCLUB • CONCERT HALL • CHURCH • CATHEDRAL • PANORAMA • 2-CH SURROUND • 2-CHANNEL • MONO LOGIC • MONO SURROUND • MONO • 5.1 5.1 FILM • 5.1 5.1 TV • 5.1 5.1 MUSIC • THX SurEX • THX MUSIC • DIGITAL EX • 5.1 2-CHANNEL • 5.1 MONO LOGIC • 5.1 MONO SURR • 5.1 MONO • DTS 5.1 FILM • DTS 5.1 MUSIC • DTS THX • DTS THX MUSIC • DTS 2-CHAN • 5.1a BYPASS • 2CH BYPASS</i>	
Listening Mode Menu Option & Parameter Descriptions	5-29

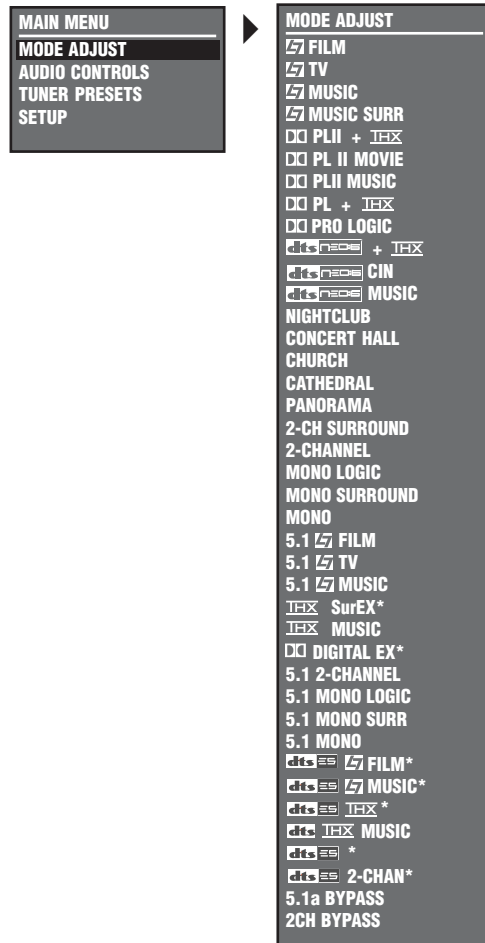

MODE ADJUST

Selecting the MAIN MENU MODE ADJUST option opens the MODE ADJUST menu shown to the left, which can be used to select a listening mode for adjustment. When the MODE ADJUST menu opens, the currently activated listening mode is highlighted.

Selecting a listening mode does not activate that listening mode for the current input source. Rather, selecting a listening mode opens the corresponding listening mode menu, which can be used to customize the activated listening mode. These adjustments are applied when that listening mode is selected with one of the methods described in the Listening Mode Activation section that begins below.

LISTENING MODE ACTIVATION

Listening modes are available for 2-channel, Dolby Digital, DTS(-ES) and analog input sources. The MC-4 allows listening mode selection for all sources. In some cases, the MC-4 automatically activates a listening mode in response to certain commands. For this reason, it is important to understand the three methods through which listening mode activation occurs.

Listening modes can be activated with

- the INPUT SETUP menu preferred listening mode selection parameters.
- the front panel or remote control Mode ▲ and ▼ buttons.
- the remote control mode family selection buttons.

PREFERRED LISTENING MODE SELECTION PARAMETERS

The INPUT SETUP menus include four preferred listening mode selection parameters labeled 2-CH, DOLBY D, DTS(-ES) and 5.1a. These parameters can be used to select a preferred listening mode for 2-channel, Dolby Digital, DTS(-ES) and 5.1a input sources. The MC-4 automatically activates the selected listening mode whenever a new input is selected or a new input source is present. See “Selecting Preferred Listening Modes” on page 3-13 for more information.







MODE ▲ AND ▼ BUTTONS

The front panel and remote control Mode ▲ and ▼ buttons can be used to audition listening modes with the current input source. Pressing these buttons scrolls upward (▲) and downward (▼) through listening modes available for the current source. Listening modes are scrolled in the order that appears on the MODE ADJUST menu.

For example, if a 2-channel input source is present, the Mode ▲ and ▼ buttons scroll through available 2-channel listening modes. The selected listening mode appears in the bottom-left corner of the two-line status.

MODE FAMILY SELECTION BUTTONS

The remote control mode family selection buttons can be used to activate the L7 Film, L7 Music, L7 TV, L7 Music Surround, Dolby, DTS(-ES) or THX listening mode that is appropriate for the input source. For instance, if the L7 button is pressed while a 2-channel source is present, the L7 FILM listening mode is activated. The table in the next column indicates the listening modes associated with each mode family selection button.

Button	2-Channel Sources	Dolby Digital Sources	DTS(-ES) Sources
	L7 FILM	5.1 L7 FILM	DTS(-ES) L7 FILM
	DOLBY PLII MOVIE	DOLBY DIGITAL*	MODE SELECTION NOT AVAILABLE**
	DTS Neo:6 FILM	MODE SELECTION NOT AVAILABLE**	DTS(-ES)
	DOLBY PLII + THX	5.1 THX*	DTS-ES THX
	L7 MUSIC	5.1 L7 MUSIC	DTS(-ES) L7 MUSIC
	L7 TV	5.1 L7 TV	MODE SELECTION NOT AVAILABLE**

* These listening mode names differ depending on the input source, the speaker configuration and certain parameter settings.

** The MODE SELECTION NOT AVAILABLE message appears in the on-screen and front panel displays when no listening mode is available for the input source that is present.

FILM

MODE ADJUST ▶ **FILM**

- A proprietary Lexicon listening mode.
- Designed for enhanced playback of 2-channel stereo or matrix-encoded film sources.
- Derives seven channels from 2-channel input sources, as well as full-frequency stereo surround channels that realistically increase the perceived width, length and sense of envelopment of the listening space.
- Provides remarkable improvement compared to other decoders.
- Recommended for 2-channel film sources.

Option/ Parameter	Default Setting	Possible Settings
AUTO AZIMUTH	ON	ON, OFF
VOCAL ENHANCE	+0.0dB	+6.0dB, +3.0dB, +0.0dB
RE-EQUALIZER	ON	ON, OFF
SOUND STAGE	REAR	FRONT, NEUTRAL, REAR
5 SPKR ENHANCE	ON	ON, OFF
BASS ENHANCE	OFF	ON, OFF
SURR ROLLOFF	7.0kHz	500Hz to 20.0kHz, OFF
REAR DLY OFFSET	15ms	OFF, 1ms to 30ms
OUTPUT LEVELS	—	—
CUSTOM	—	—

See "Listening Mode Menu Option & Parameter Descriptions" on page 5-29 for detailed descriptions of these options and parameters.

TV

MODE ADJUST ▶ **TV**

- A proprietary Lexicon listening mode.
- Based on the L7 FILM listening mode, but specifically tailored for broadcast sources.
- Designed for playback of 2-channel stereo or matrix-encoded broadcast sources.
- Recommended for 2-channel broadcast sources.

Option/ Parameter	Default Setting	Possible Settings
AUTO AZIMUTH	ON	ON, OFF
VOCAL ENHANCE	+0.0dB	+6.0dB, +3.0dB, +0.0dB
FRONT STEERING	FILM	OFF, MSURR, MUSIC, FILM
RE-EQUALIZER	OFF	ON, OFF
SOUND STAGE	REAR	FRONT, NEUTRAL, REAR
5 SPKR ENHANCE	ON	ON, OFF
BASS ENHANCE	OFF	ON, OFF
SURR ROLLOFF	7.0kHz	500Hz to 20.0kHz, OFF
REAR DLY OFFSET	15ms	OFF, 1ms to 30ms
OUTPUT LEVELS	—	—
CUSTOM	—	—

See "Listening Mode Menu Option & Parameter Descriptions" on page 5-29 for detailed descriptions of these options and parameters.

MUSIC

MODE ADJUST ▶ MUSIC

- A proprietary Lexicon listening mode.
- Designed for playback of 2-channel stereo or matrix-encoded music sources.
- Recommended for 2-channel music sources.

Option/ Parameter	Default Setting	Possible Settings
VOCAL ENHANCE	+0.0dB	+6.0dB, +3.0dB, +0.0dB
FRONT STEERING	MUSIC	OFF, MSURR, MUSIC, FILM
SOUND STAGE	NEUTRAL	FRONT, NEUTRAL, REAR
5 SPKR ENHANCE	ON	ON, OFF
BASS ENHANCE	OFF	ON, OFF
SURR ROLLOFF	7.0kHz	500Hz to 20.0kHz, OFF
REAR DLY OFFSET	15ms	OFF, 1ms to 30ms
OUTPUT LEVELS	—	—
CUSTOM	—	—

See “Listening Mode Menu Option & Parameter Descriptions” on page 5-29 for detailed descriptions of these options and parameters.

MUSIC SURR

MODE ADJUST ▶ MUSIC SURR

- A proprietary Lexicon listening mode.
- Similar to the MUSIC SURROUND listening mode in other Lexicon products.
- Designed for playback of 2-channel stereo music sources recorded in real spaces and for playback of recordings that contain added reverb.
- Extracts ambient sounds from the input source and sends these sounds to all speakers. Ambient sounds are heard from all directions, creating a realistic playback presentation that simulates what listeners experience in real spaces.
- Recommended for classical music sources, which are often recorded in real spaces with added reverb to enhance the stereo mix.

Option/ Parameter	Default Setting	Possible Settings
VOCAL ENHANCE	+0.0dB	+6.0dB, +3.0dB, +0.0dB
FRONT STEERING	MSURR	OFF, MSURR, MUSIC, FILM
SOUND STAGE	NEUTRAL	FRONT, NEUTRAL, REAR
5 SPKR ENHANCE	ON	ON, OFF
BASS ENHANCE	OFF	ON, OFF
SURR ROLLOFF	7.0kHz	500Hz to 20.0kHz, OFF
REAR DLY OFFSET	15ms	OFF, 1ms to 30ms
OUTPUT LEVELS	—	—
CUSTOM	—	—

See “Listening Mode Menu Option & Parameter Descriptions” on page 5-29 for detailed descriptions of these options and parameters.

DOLBY + THX

MODE ADJUST ▶ **DOLBY + THX**

- Designed for playback of Dolby Surround-encoded sources.
- Uses Dolby Pro Logic II decoding to derive five channels from Dolby Surround-encoded sources.
- Applies THX re-equalization to simulate high-frequency rolloffs that occur in movie theaters. Most films are mixed for movie theaters and might sound too bright when played back in home theaters without re-equalization.
- Applies THX timbre matching to minimize timbre differences between the front and surround channels, which results in smoother sound movements between them.
- Recommended for home theaters with THX-certified speaker setups.

Option/ Parameter	Default Setting	Possible Settings
RE-EQUALIZER	ON	ON, OFF
OUTPUT LEVELS	—	—
CUSTOM	—	—

See “Listening Mode Menu Option & Parameter Descriptions” on page 5-29 for detailed descriptions of these options and parameters.

DOLBY MOVIE

MODE ADJUST ▶ **DOLBY MOVIE**

- Similar to the DOLBY LOGIC listening mode, but uses full-frequency stereo surround channels to realistically increase the perceived width of the listening space.
- Designed for playback of Dolby Surround-encoded sources.
- Decodes five channels from Dolby Surround-encoded sources.
- Provides impressive enhancement compared to Dolby Pro Logic decoding.
- Appropriate for Dolby Surround-encoded film sources.

**Option/
Parameter**

OUTPUT LEVELS

CUSTOM

See “Listening Mode Menu Option & Parameter Descriptions” on page 5-29 for detailed descriptions of these options and parameters.

DOLBY PII MUSIC**MODE ADJUST** ▶ **DOLBY PII MUSIC**

- Similar to the DOLBY PLII MOVIE listening mode.
- Designed for playback of stereo music sources.

Option/ Parameter	Default Setting	Possible Settings
PANORAMA	OFF	ON, OFF
CTR WIDTH	3	MIN, 1 to 6, MAX
DIMENSION	NEUTRAL	FRONT, NEUTRAL, REAR
SURROUND DLY	10ms	0ms to 15ms
OUTPUT LEVELS	—	—
CUSTOM	—	—

See "Listening Mode Menu Option & Parameter Descriptions" on page 5-29 for detailed descriptions of these options and parameters.

DOLBY PL + THX**MODE ADJUST** ▶ **DOLBY PL + THX**

- Designed for playback of Dolby Surround-encoded sources.
- Decodes four channels from Dolby Surround-encoded sources.
- Uses a mono surround channel with a high-frequency rolloff above 7kHz.
- Applies THX re-equalization to simulate high-frequency rolloffs that occur in movie theaters. Most films are mixed for movie theaters and might sound too bright when played back in home theaters without re-equalization.
- Applies THX timbre matching to minimize timbre differences between the front and surround channels, which results in smoother sound movements between them.
- Recommended for home theaters with THX-certified speaker setups.

Option/ Parameter	Default Setting	Possible Settings
RE-EQUALIZER	ON	ON, OFF
OUTPUT LEVELS	—	—
CUSTOM	—	—

See "Listening Mode Menu Option & Parameter Descriptions" on page 5-29 for detailed descriptions of these options and parameters.

DOLBY LOGIC

MODE ADJUST > DOLBY LOGIC

- Designed for playback of Dolby Surround-encoded sources.
- Decodes four channels from Dolby Surround-encoded sources.
- Uses a mono surround channel with a high-frequency rolloff above 7kHz.
- Available for comparison purposes, particularly with the L7 FILM, DOLBY PLII MOVIE and DTS Neo:6 FILM listening modes.

**Option/
Parameter**

OUTPUT LEVELS

CUSTOM

See "Listening Mode Menu Option & Parameter Descriptions" on page 5-29 for detailed descriptions of these options and parameters.

DTS NEO + THX

MODE ADJUST > DTS NEO + THX

- Designed for playback of matrix-encoded digital stereo film sources.
- Applies THX re-equalization to simulate high-frequency rolloffs that occur in movie theaters. Most films are mixed for movie theaters and might sound too bright when played back in home theaters without re-equalization.

Option/ Parameter	Default Setting	Possible Settings
RE-EQUALIZER	ON	ON, OFF
OUTPUT LEVELS	—	—
CUSTOM	—	—

See "Listening Mode Menu Option & Parameter Descriptions" on page 5-29 for detailed descriptions of these options and parameters.

 CIN

  CIN

- Designed for playback of matrix-encoded digital stereo film sources.
- Derives six channels when both side and rear speakers are present (rear channels will be in parallel). Derives five channels when only side or rear speakers are present. The subwoofer channel is generated through bass management in the MC-4.

**Option/
Parameter**

 OUTPUT LEVELS

 CUSTOM

See "Listening Mode Menu Option & Parameter Descriptions" on page 5-29 for detailed descriptions of these options and parameters.

 MUSIC

  MUSIC

- Designed for playback of matrix-encoded digital stereo music sources.
- Derives six channels when both side and rear speakers are present (rear channels will be in parallel). Derives five channels when only side or rear speakers are present. The subwoofer channel is generated through bass management in the MC-4.

**Option/
Parameter**

 OUTPUT LEVELS

 CUSTOM

See "Listening Mode Menu Option & Parameter Descriptions" on page 5-29 for detailed descriptions of these options and parameters.

Please note the following about DTS Neo:6 listening mode activation:

- The DTS Neo:6 listening modes cannot be assigned as the preferred listening mode for 2-channel sources. However, when the 2-CH parameter is set to USE LAST, the MC-4 will automatically activate a DTS Neo:6 listening mode if a DTS Neo:6 listening mode was activated the last time a 2-channel source was present.
- The MC-4 will not automatically activate the DTS Neo:6 listening modes unless a 44.1kHz or 48kHz PCM digital source is present. The DTS Neo:6 listening modes are not available with 88.2kHz or 96kHz, Dolby Digital or analog sources.
- The DTS Neo:6 MUSIC listening mode can be activated with the front panel or remote control Mode ▲ and ▼ buttons. The DTS Neo:6 CIN listening mode can also be activated with the remote control DTS button when a 2-channel input source is present.

NIGHTCLUB

MODE ADJUST ▶ **NIGHTCLUB**

- Designed for playback of “dry” music sources that benefit from the addition of room reflections, especially music sources that lack ambience in the recording.
- Generates early reflections to simulate small, intimate listening spaces.
- Sends early reflections to the front, side and rear channels.
- Unlike other room simulation listening modes, this mode uses a proprietary reverb algorithm. This algorithm is inherited from Lexicon professional products, which a majority of recording engineers rely on to add ambience to recordings.

Option/ Parameter	Default Setting	Possible Settings
CENTER DEPTH	11	0 to 18
SPEECH DETECT	ON	ON, OFF
SIZE	5m	4m to 20m
LIVENESS	196ms	30ms to 20.2s
PRE-DELAY	5ms	OFF, 1ms to 100ms
ROLLOFF	9.0kHz	500Hz to 20.0kHz, OFF
EFFECT LVL	+3dB	-12dB to +6dB
OUTPUT LEVELS	—	—
CUSTOM	—	—

See “Listening Mode Menu Option & Parameter Descriptions” on page 5-29 for detailed descriptions of these options and parameters.

CONCERT HALL

MODE ADJUST ▶ **CONCERT HALL**

- Generates early reflections to simulate large listening spaces.
- Sends early reflections to the front, side and rear channels.
- Unlike other room simulation listening modes, this mode uses a proprietary reverb algorithm. This algorithm is inherited from Lexicon professional products, which a majority of recording engineers rely on to add ambience to recordings.

Option/ Parameter	Default Setting	Possible Settings
CENTER DEPTH	12	0 to 18
SPEECH DETECT	ON	ON, OFF
SIZE	20m	4m to 20m
LIVENESS	1.72s	30ms to 20.2s
PRE-DELAY	OFF	OFF, 1ms to 100ms
ROLLOFF	2.4kHz	500Hz to 20.0kHz, OFF
EFFECT LVL	-2dB	-12dB to +6dB
OUTPUT LEVELS	—	—
CUSTOM	—	—

See “Listening Mode Menu Option & Parameter Descriptions” on page 5-29 for detailed descriptions of these options and parameters.

CHURCH**MODE ADJUST** ▶ **CHURCH**

- Uses a reverb algorithm to emphasize the rich, smooth, reverberant decay characteristic of small and medium listening spaces with long reverberation time relative to their size, such as churches and chambers.
- Unlike other room simulation listening modes, this mode uses a proprietary reverb algorithm. This algorithm is inherited from Lexicon professional products, which a majority of recording engineers rely on to add ambience to recordings.

Option/ Parameter	Default Setting	Possible Settings
CENTER DEPTH	5	0 to 18
SPEECH DETECT	ON	ON, OFF
SIZE	20m	4m to 30m
MID RT	1.56s	24ms to 24.3s
BASS RT	1.87s	5ms to 48.6s
PRE-DELAY	24ms	OFF, 1ms to 100ms
ROLLOFF	2.4kHz	500Hz to 20.0kHz, OFF
EFFECT LVL	-3dB	-12dB to +6dB
OUTPUT LEVELS	—	—
CUSTOM	—	—

See "Listening Mode Menu Option & Parameter Descriptions" on page 5-29 for detailed descriptions of these options and parameters.

CATHEDRAL**MODE ADJUST** ▶ **CATHEDRAL**

- Similar to the CHURCH listening mode.
- Uses a reverb algorithm to emphasize the rich, smooth, reverberant decay characteristic of large listening spaces with long reverberation time relative to their size, such as cathedrals.
- Unlike other room simulation listening modes, this mode uses a proprietary reverb algorithm. This algorithm is inherited from Lexicon professional products, which a majority of recording engineers rely on to add ambience to recordings.

Option/ Parameter	Default Setting	Possible Settings
CENTER DEPTH	12	0 to 18
SPEECH DETECT	ON	ON, OFF
SIZE	30m	4m to 30m
MID RT	3.72s	24ms to 24.3s
BASS RT	4.47s	5ms to 48.6s
PRE-DELAY	23ms	OFF, 1ms to 100ms
ROLLOFF	3.1kHz	500Hz to 20.0kHz, OFF
EFFECT LVL	-8dB	-12dB to +6dB
OUTPUT LEVELS	—	—
CUSTOM	—	—

See "Listening Mode Menu Option & Parameter Descriptions" on page 5-29 for detailed descriptions of these options and parameters.

PANORAMA

MODE ADJUST ▶ **PANORAMA**

- Designed for playback of stereo and matrix-encoded sources.
- Uses proprietary Lexicon algorithms to move the stereo image outward from the front speakers, producing a wider stereo field with greater depth.
- Depends on proper location of the listening position and front speakers. When the front speakers are positioned close to either side of the display device, the effect is produced over a wider area than when the front speakers are positioned at a large angle from the display device.

Option/ Parameter	Default Setting	Possible Settings
EFFECT LVL	+4dB	-12dB to +6dB
BASS CONTENT	STEREO	BINAURL, MONO, STEREO
LOW FREQ WIDTH	+0	-25dB to +25dB
SURR ROLLOFF	3.1kHz	500Hz to 20.0kHz, OFF
REAR DLY OFFSET	15ms	OFF, 1ms to 30ms
INPUT BALANCE	< >	L< to < > to >R
CALIBRATION	—	—
OUTPUT LEVELS	—	—
CUSTOM	—	—

See "Listening Mode Menu Option & Parameter Descriptions" on page 5-29 for detailed descriptions of these options and parameters.

PANORAMA CALIBRATION

MODE ADJUST ▶ **PANORAMA** ▶ **CALIBRATION**

- The PANORAMA listening mode must be calibrated to take full advantage of its effects.
- For best results, it is recommended that you center the primary listening position between the front left and right speakers. Otherwise, the PANORAMA listening mode will be calibrated with various results.

Option/ Parameter	Default Setting	Possible Settings
SOURCE	LEFT & RIGHT	RIGHT, LEFT & RIGHT, LEFT
SPEAKER ANGLE	30deg	10deg to 90deg
LISTENER POS	+0	-127 to +127

See "Listening Mode Menu Option & Parameter Descriptions" on page 5-29 for detailed descriptions of these options and parameters.

To calibrate the PANORAMA listening mode:

1. Remove all obstructions between the speakers and the primary listening position.
2. Make sure the distances between the speakers and the primary listening position are properly measured. Then, enter these distances on the SPEAKER DISTANCES menu.
3. Sit in the primary listening position. If the primary listening position is not centered between the front left and right speakers, set the LISTENER POS parameter to compensate for the difference.
4. Set the SOURCE parameter to RIGHT.
5. Begin playback of the calibration source. It is recommended that you use a familiar stereo source.

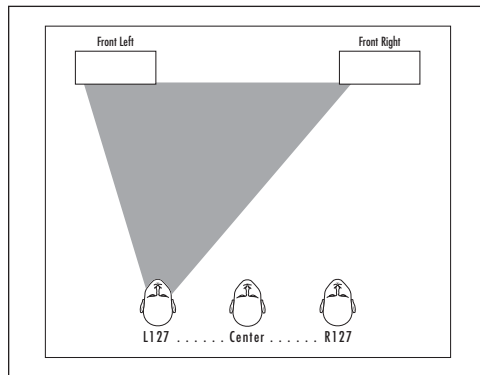
LISTENER POS Parameter Settings

Negative settings (-127 to -1) compensate for primary listening positions located to the left of the center between the front left and right speakers.

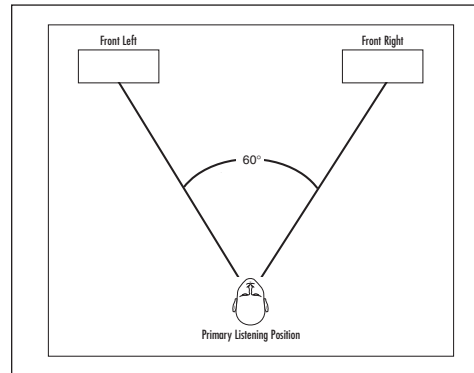

The +0 setting indicates a primary listening position centered between the front left and right speakers.

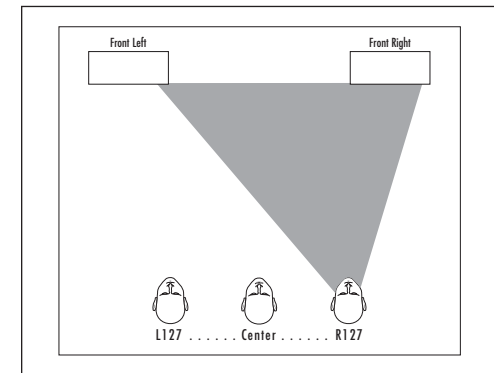

Positive settings (+1 to +127) compensate for primary listening positions located to the right of the center between the front left and right speakers.

6. When playback of the calibration source is in progress, set the SPEAKER ANGLE parameter (next column) so the sound is not heard in the left ear.
7. Set the SOURCE parameter to LEFT.
8. When playback of the calibration source is in progress, set the SPEAKER ANGLE parameter so the sound is not heard in the right ear.
9. Set the SOURCE parameter to LEFT & RIGHT to confirm the SPEAKER ANGLE and LISTENER POS parameter settings. When the PANORAMA listening mode is properly calibrated, the sound should be perceived to come from all around the primary listening position. If this does not occur, begin again with step 1.

SOURCE

RIGHT, LEFT & RIGHT, LEFT

Controls the perceived direction of the calibration source signal. When set to RIGHT, the sound is perceived to come from the right of the primary listening position. When set to LEFT, the sound is perceived to come from the left of the primary listening position. When set to LEFT & RIGHT, the sound is perceived to come from all around the primary listening position.

Note:

The SOURCE parameter controls the perceived direction of the sound, although both the front left and right speakers generate the calibration source signal.

PANORAMA CALIBRATION *(continued)*

SPEAKER ANGLE 10deg to 90deg

Compensates for a wide or narrow speaker angle relative to the primary listening position. Select the setting closest to the angle between the front left and right speakers and the primary listening position.

LISTENER POS -127 to +127

Compensates for primary listening positions that are not centered between the front left and right speakers. Each increment within the -127 to +127 parameter range represents about one-third of an inch.

Note:

The LISTENER POS parameter range might extend past the location of the front left and right speakers.

2-CH SURROUND

MODE ADJUST ▶ **2-CH SURROUND**

- Designed for playback of stereo sources.
- Sends stereo sources to all channels.
- Recommended for background music.

**Option/
Parameter**

OUTPUT LEVELS

CUSTOM

See "Listening Mode Menu Option & Parameter Descriptions" on page 5-29 for detailed descriptions of these options and parameters.

2-CHANNEL

MODE ADJUST ▶ **2-CHANNEL**

- Designed for playback of stereo sources.
- Sends stereo sources to the front and subwoofer channels.
- Recommended for audio purists and comparison purposes with other listening modes.

Option/ Parameter	Default Setting	Possible Settings
SUB LEVEL	+0dB	OFF, -30dB to +12dB
CUSTOM	—	—

See "Listening Mode Menu Option & Parameter Descriptions" on page 5-29 for detailed descriptions of these options and parameters.

MONO LOGIC**MODE ADJUST** ▶ **MONO LOGIC**

- Designed for playback of mono sources.
- Uses proprietary Lexicon reverb algorithms to realistically expand mono sources to use all channels, dramatically increasing the perceived width and sense of envelopment of the listening space.

Option/ Parameter	Default Setting	Possible Settings
EFFECT LVL	-9dB	-12dB to +6dB
ACADEMY FILTER	ON	ON, OFF
SURR ROLLOFF	3.1kHz	500Hz to 20.0kHz, OFF
OUTPUT LEVELS	—	—
CUSTOM	—	—

See "Listening Mode Menu Option & Parameter Descriptions" on page 5-29 for detailed descriptions of these options and parameters.

MONO SURROUND**MODE ADJUST** ▶ **MONO SURROUND**

- Designed for playback of mono sources.
- Sends mono sources to all channels.

**Option/
Parameter**

OUTPUT LEVELS
CUSTOM

See "Listening Mode Menu Option & Parameter Descriptions" on page 5-29 for detailed descriptions of these options and parameters.

MONO**MODE ADJUST** ▶ **MONO**

- Designed for playback of mono sources.
- Sends mono sources to the center channel.

Option/ Parameter	Default Setting	Possible Settings
SUB LEVEL	+0dB	OFF, -30dB to +12dB
CUSTOM	—	—

See "Listening Mode Menu Option & Parameter Descriptions" on page 5-29 for detailed descriptions of these options and parameters.

5.1  FILM

MODE ADJUST ▶ 5.1  FILM

- A proprietary Lexicon listening mode.
- Designed for playback of 5.1-channel Dolby Digital-encoded film sources.
- Derives seven channels from 5.1-channel input sources. When both side and rear speakers are present, the 5.1 L7 FILM listening mode also increases the perceived length and sense of envelopment of the listening space.
- Provides remarkable improvement compared to other decoders.
- Recommended for 5.1-channel Dolby Digital-encoded film sources.

Option/ Parameter	Default Setting	Possible Settings
VOCAL ENHANCE	+0.0dB	+6.0dB, +3.0dB, +0.0dB
5 SPKR ENHANCE	ON	ON, OFF
BASS ENHANCE	OFF	ON, OFF
RE-EQUALIZER	ON	ON, OFF
REAR DLY OFFSET	15ms	OFF, 1ms to 30ms
COMPRESSION	OFF	AUTO, ON, OFF
LFE MIX	+0.0dB	-10.0dB to +0.0dB
OUTPUT LEVELS	—	—
CUSTOM	—	—

See "Listening Mode Menu Option & Parameter Descriptions" on page 5-29 for detailed descriptions of these options and parameters.

5.1  TV

MODE ADJUST ▶ 5.1  TV

- A proprietary Lexicon listening mode.
- Based on the 5.1 L7 FILM listening mode, but specifically tailored for broadcast sources.
- Designed for playback of 5.1-channel Dolby Digital-encoded broadcast sources.
- Recommended for 5.1-channel Dolby Digital-encoded broadcast sources.

Option/ Parameter	Default Setting	Possible Settings
VOCAL ENHANCE	+0.0dB	+6.0dB, +3.0dB, +0.0dB
5 SPKR ENHANCE	ON	ON, OFF
BASS ENHANCE	OFF	ON, OFF
RE-EQUALIZER	OFF	ON, OFF
REAR DLY OFFSET	15ms	OFF, 1ms to 30ms
COMPRESSION	OFF	AUTO, ON, OFF
LFE MIX	+0.0dB	-10.0dB to +0.0dB
OUTPUT LEVELS	—	—
CUSTOM	—	—

See "Listening Mode Menu Option & Parameter Descriptions" on page 5-29 for detailed descriptions of these options and parameters.

5.1 MUSIC

MODE ADJUST ▸ **5.1  MUSIC**

- A proprietary Lexicon listening mode.
- Based on the 5.1 L7 FILM listening mode, but specifically tailored for music sources.
- Designed for playback of 5.1-channel Dolby Digital-encoded music sources.
- Recommended for 5.1-channel Dolby Digital-encoded music sources.

Option/ Parameter	Default Setting	Possible Settings
VOCAL ENHANCE	+0.0dB	+6.0dB, +3.0dB, +0.0dB
5 SPKR ENHANCE	ON	ON, OFF
BASS ENHANCE	OFF	ON, OFF
RE-EQUALIZER	OFF	ON, OFF
REAR DLY OFFSET	15ms	OFF, 1ms to 30ms
COMPRESSION	OFF	AUTO, ON, OFF
LFE MIX	+0.0dB	-10.0dB to +0.0dB
OUTPUT LEVELS	—	—
CUSTOM	—	—

See "Listening Mode Menu Option & Parameter Descriptions" on page 5-29 for detailed descriptions of these options and parameters.

ULTRA2, & SurEX

MODE ADJUST ▸ ** OR  ULTRA2 OR 5.1  SurEX**

- Designed for playback of 5.1-channel Dolby Digital film sources.
- Listening mode name differs depending on the encoding present in the input source, the SURROUND EX parameter setting and the speaker setup. The table on the next page indicates the conditions in which THX Surround EX and THX Ultra2 decoding are engaged.
- Allows 7-channel playback of 5.1-channel Dolby Digital sources without Surround EX encoding.
- Applies THX re-equalization to simulate high-frequency rolloffs that occur in movie theaters. Most films are mixed for movie theaters and might sound too bright when played back in home theaters without re-equalization.
- Applies THX timbre matching to minimize timbre differences between the front and surround channels, which results in smoother sound movements between them.
- When the THX ULTRA2 listening mode is activated, ASA processing is applied to signals sent to the rear speakers. See "ASA" on page 3-32 for more information.
- When the THX ULTRA2 listening mode is activated, adaptive de-correlation increases the perceived width of the listening space. De-correlation of the mono surround channel increases the perceived width of the surround field in home theaters.
- When the THX SurEX listening mode is activated, matrix decoding derives three surround channels from 5.1-channel Dolby Digital sources.
- Recommended for home theaters with THX-certified speaker setups.

Option/ Parameter	Default Setting	Possible Settings
RE-EQUALIZER	ON	ON, OFF
SURROUND EX	AUTO	AUTO, ON, OFF
COMPRESSION	OFF	AUTO, ON, OFF
LFE MIX	+0.0dB	-10.0dB to +0.0dB
OUTPUT LEVELS	—	—
CUSTOM	—	—

See "Listening Mode Menu Option & Parameter Descriptions" on page 5-29 for detailed descriptions of these options and parameters.

The table below indicates the conditions in which THX Surround EX and THX Ultra2 decoding are engaged.

- THX Surround EX decoding is engaged when the SURROUND EX parameter is set to ON or the SURROUND EX parameter is set to AUTO and a flagged 5.1-channel Dolby Digital source with THX Surround EX encoding is detected.
- THX Ultra2 decoding is engaged when the SURROUND EX parameter is set to OFF or the SURROUND EX parameter is set to AUTO and a non-flagged 5.1-channel Dolby Digital source with or without THX Surround EX encoding is detected.

- Listening mode name differs depending on the encoding present in the input source, the SURROUND EX parameter setting and the speaker setup.
 - The THX ULTRA2 listening mode is available when THX Ultra2 decoding is engaged.
 - The THX SurEX listening mode is available when THX Surround EX decoding is engaged.
 - The THX listening mode is available when neither THX Ultra2 nor Surround EX decoding is engaged.
 - The THX ULTRA2 and THX SurEX listening modes cannot be activated unless side and rear speakers are present.

Note:

The MC-4 cannot automatically detect THX Surround EX encoding in non-flagged 5.1-channel Dolby Digital sources. A non-flagged source does not include information in the input signal that identifies THX Surround EX encoding.

Parameter Setting \ Input Source	5.1-Channel Dolby Digital	5.1-Channel Surround EX-Encoded Dolby Digital (Flagged)	5.1-Channel Surround EX-Encoded Dolby Digital (Non-Flagged)
SURROUND EX: AUTO	5.1 THX ULTRA2	5.1 THX SurEX	5.1 THX ULTRA2
SURROUND EX: ON	5.1 THX SurEX	5.1 THX SurEX	5.1 THX SurEX
SURROUND EX: OFF	5.1 THX ULTRA2	5.1 THX ULTRA2	5.1 THX ULTRA2

THX MUSIC**MODE ADJUST** ▶ **THX MUSIC**

- Designed for playback of 5.1-channel Dolby Digital music sources.
- The 5.1 THX MUSIC listening mode cannot be activated unless side and rear speakers are present.
- ASA processing is applied to signals sent to the rear speakers. See “ASA” on page 3-32 for more information.
- Recommended for home theaters with THX-certified speaker setups.

Option/ Parameter	Default Setting	Possible Settings
COMPRESSION	OFF	AUTO, ON, OFF
LFE MIX	+0.0dB	-10.0dB to +0.0dB
OUTPUT LEVELS	—	—
CUSTOM	—	—

See “Listening Mode Menu Option & Parameter Descriptions” on page 5-29 for detailed descriptions of these options and parameters.

Note:

The 5.1 THX MUSIC listening mode can only be activated with the front panel or remote control Mode ▲ and ▼ buttons.

DOLBY DIGITAL & DOLBY DIGITAL EX**MODE ADJUST** ▶ **DOLBY DIGITAL** OR **DOLBY DIGITAL EX**

- Designed for playback of 5.1-channel Dolby Digital sources. The DOLBY DIGITAL listening mode is recommended for Dolby Digital sources recorded with Dolby Digital Surround EX. This listening mode can also be used with 5.1-channel Dolby Digital sources with mixed results.
- Listening mode name differs depending on the encoding present in the input source, the EX DECODING parameter setting and the speaker setup. The table on the next page indicates the conditions in which Dolby Digital Surround EX decoding is engaged.
- Decodes 5.1 discrete channels from 5.1-channel Dolby Digital sources. The five main channels are full-frequency. The .1 channel, often referred to as LFE information, has a limited frequency range of 120Hz.
- When the DOLBY DIGITAL EX listening mode is activated, matrix decoding derives a surround back channel from the other surround channels.

Option/ Parameter	Default Setting	Possible Settings
EX DECODING	AUTO	AUTO, ON, OFF
COMPRESSION	OFF	AUTO, ON, OFF
LFE MIX	+0.0dB	-10.0dB to +0.0dB
OUTPUT LEVELS	—	—
CUSTOM	—	—

See “Listening Mode Menu Option & Parameter Descriptions” on page 5-29 for detailed descriptions of these options and parameters.

The table below indicates the conditions in which Dolby Digital Surround EX decoding is engaged.

- Dolby Digital Surround EX decoding is engaged when the EX DECODING parameter is set to ON or the EX DECODING parameter is set to AUTO and a flagged 5.1-channel Dolby Digital source recorded with Dolby Digital Surround EX is detected.
- Dolby Digital Surround EX decoding is not engaged when the EX DECODING parameter is set to OFF or the EX DECODING parameter is set to AUTO and a non-flagged 5.1-channel Dolby Digital source recorded with or without Dolby Digital Surround EX is detected.
- Listening mode name differs depending on the encoding present in the input source, the EX DECODING parameter setting and the speaker setup.
 - The DOLBY DIGITAL EX listening mode is available when Dolby Digital Surround EX decoding is engaged.
 - The DOLBY DIGITAL listening mode is available when Dolby Digital Surround EX decoding is not engaged.
 - The DOLBY DIGITAL EX listening mode cannot be activated unless both side and rear speakers are present.

Note:

The MC-4 cannot automatically detect Dolby Digital Surround EX encoding in non-flagged 5.1-channel Dolby Digital sources. A non-flagged source does not include information in the input signal that identifies Dolby Digital Surround EX encoding.

Parameter Setting \ Input Source	5.1-Channel Dolby Digital	5.1-Channel Dolby Digital EX (Flagged)	5.1-Channel Dolby Digital EX (Non-Flagged)
EX DECODING: AUTO	DOLBY DIGITAL	DOLBY DIGITAL EX	DOLBY DIGITAL
EX DECODING: ON	DOLBY DIGITAL EX	DOLBY DIGITAL EX	DOLBY DIGITAL EX
EX DECODING: OFF	DOLBY DIGITAL	DOLBY DIGITAL	DOLBY DIGITAL

5.1 2-CHANNEL

MODE ADJUST ▶ 5.1 2-CHANNEL

- Designed for converting 5.1-channel Dolby Digital-encoded input sources into 2-channel Logic 7-encoded output signals.
- Sends downmixed 5.1-channel Dolby Digital input signals to the front speakers and subwoofer.
- Recommended for recording purposes.

Option/ Parameter	Default Setting	Possible Settings
CENTER MIX	+0dB	-25dB to +5dB
SURROUND MIX	+0dB	-5dB to +5dB
CNTR DLY SAMPLES	+0	-127 to +127
MASTER LEVEL	+0dB	-5dB to +5dB
COMPRESSION	OFF	AUTO, ON, OFF
LFE MIX	+0.0dB	-20.0dB to +0.0dB
SUB LEVEL	+0dB	OFF, -30dB to +12dB
CUSTOM	—	—

See "Listening Mode Menu Option & Parameter Descriptions" on page 5-29 for detailed descriptions of these options and parameters.

5.1 MONO LOGIC

MODE ADJUST ▶ 5.1 MONO LOGIC

- Designed for playback of Dolby Digital-encoded mono sources.
- Uses proprietary Lexicon reverb algorithms to realistically expand mono sources to use all channels, dramatically increasing the perceived width and sense of envelopment of the listening space.

Option/ Parameter	Default Setting	Possible Settings
EFFECT LVL	-9dB	-12dB to +6dB
ACADEMY FILTER	ON	ON, OFF
SURR ROLLOFF	3.1kHz	500Hz to 20.0kHz, OFF
OUTPUT LEVELS	—	—
CUSTOM	—	—

See "Listening Mode Menu Option & Parameter Descriptions" on page 5-29 for detailed descriptions of these options and parameters.

Note:

When a 1.0 Dolby Digital input source is present, the MC-4 automatically activates the 5.1 MONO LOGIC listening mode.

5.1 MONO SURR

MODE ADJUST ▶ **5.1 MONO SURR**

- Designed for playback of Dolby Digital-encoded mono sources.
- Sends mono signals to all channels.

**Option/
Parameter**

OUTPUT LEVELS

CUSTOM

See "Listening Mode Menu Option & Parameter Descriptions" on page 5-29 for detailed descriptions of these options and parameters.

5.1 MONO

MODE ADJUST ▶ **5.1 MONO**

- Designed for playback of Dolby Digital-encoded mono sources.
- Sends a mono signal to the center channel.

**Option/
Parameter**

SUB LEVEL

CUSTOM

**Default
Setting**

+0dB

—

**Possible
Settings**

OFF, -30dB to +12dB

—

See "Listening Mode Menu Option & Parameter Descriptions" on page 5-29 for detailed descriptions of these options and parameters.

DECODING

The table below indicates the conditions in which DTS-ES decoding is engaged.

- DTS-ES decoding is engaged when the ES DECODING parameter is set to ON or the ES DECODING parameter is set to AUTO and a 5.1-channel matrix-encoded or 6.1-channel discrete-encoded DTS-ES source is detected.
- DTS-ES decoding is not engaged when the ES DECODING parameter is set to OFF or the ES DECODING parameter is set to AUTO and a 5.1-channel DTS source is detected.
- Listening mode names differ depending on the encoding present in the input source, the ES DECODING parameter setting and the speaker setup.
 - DTS-ES listening modes are available when DTS-ES decoding is engaged.
 - DTS listening modes are available when DTS-ES decoding is not engaged.
 - DTS-ES listening modes cannot be activated unless both side and rear speakers are present.

Note:

The table below is not applicable to the DTS-ES THX, DTS THX ULTRA2 and DTS THX MUSIC listening modes.

Parameter Setting \ Input Source	5.1-Channel DTS	5.1-Channel Matrix-Encoded DTS-ES	6.1-Channel Discrete-Encoded DTS-ES
ES DECODING: AUTO	DTS	DTS-ES	DTS-ES
ES DECODING: ON	DTS-ES	DTS-ES	DTS-ES
ES DECODING: OFF	DTS	DTS	DTS

dtc **FILM**

MODE ADJUST ▶ **dtc** **FILM**

- A proprietary Lexicon listening mode.
- Designed for playback of 5.1- and 6.1-channel DTS(-ES) film sources.
- Uses an advanced matrix to derive seven channels from 5.1- and 6.1-channel DTS(-ES) sources. When both side and rear speakers are present, the DTS(-ES) L7 FILM listening mode also increases the perceived length and sense of envelopment of the listening space.
- Provides remarkable improvement compared to other decoders.
- Recommended for 5.1- and 6.1-channel DTS(-ES) film sources.

Option/ Parameter	Default Setting	Possible Settings
VOCAL ENHANCE	+0.0dB	+6.0dB, +3.0dB, +0.0dB
5 SPKR ENHANCE	ON	ON, OFF
BASS ENHANCE	OFF	ON, OFF
RE-EQUALIZER	ON	ON, OFF
REAR DLY OFFSET	15ms	OFF, 1ms to 30ms
LFE MIX	+0.0dB	-10.0dB to +0.0dB
ES DECODING	AUTO	AUTO, ON, OFF
OUTPUT LEVELS	—	—
CUSTOM	—	—

See "Listening Mode Menu Option & Parameter Descriptions" on page 5-29 for detailed descriptions of these options and parameters.

dtc **MUSIC**

MODE ADJUST ▶ **dtc** **MUSIC**

- A proprietary Lexicon listening mode.
- Designed for playback of 5.1- and 6.1-channel DTS(-ES) music sources.
- Based on the DTS(-ES) L7 FILM listening mode, but specifically tailored for music sources.
- Recommended for 5.1- and 6.1-channel DTS(-ES) music sources.

Option/ Parameter	Default Setting	Possible Settings
VOCAL ENHANCE	+0.0dB	+6.0dB, +3.0dB, +0.0dB
5 SPKR ENHANCE	ON	ON, OFF
BASS ENHANCE	OFF	ON, OFF
REAR DLY OFFSET	15ms	OFF, 1ms to 30ms
LFE MIX	+0.0dB	-10.0dB to +0.0dB
ES DECODING	AUTO	AUTO, ON, OFF
OUTPUT LEVELS	—	—
CUSTOM	—	—

See "Listening Mode Menu Option & Parameter Descriptions" on page 5-29 for detailed descriptions of these options and parameters.

DTS THX ULTRA2 & DTS ES THX

MODE ADJUST ▶ **DTS THX ULTRA2** OR **DTS ES THX**

- Designed for playback of 5.1-channel DTS, 5.1-channel matrix-encoded DTS-ES and 6.1-channel discrete-encoded DTS-ES film sources.
- Listening mode name differs depending on the encoding present in the input source, the ES DECODING parameter setting and the speaker setup. The table below indicates the conditions in which THX Ultra2 and DTS-ES decoding are engaged.
- Allows 7-channel playback of 5.1-channel DTS sources without DTS-ES encoding.
- Applies THX re-equalization to simulate high-frequency rolloffs that occur in movie theaters. Most films are mixed for movie theaters and might sound too bright when played back in home theaters without re-equalization.
- Applies THX timbre matching to minimize timbre differences between the front and surround channels, which results in smoother sound movements between them.

- When the DTS THX ULTRA2 listening mode is activated, ASA processing is applied to signals sent to the rear speakers. See “ASA” on page 3-32 for more information.
- When the DTS THX ULTRA2 listening mode is activated, adaptive de-correlation increases the perceived width of the listening space. De-correlation of the mono surround channel increases the perceived width of the surround field in home theaters.
- Recommended for home theaters with THX-certified speaker setups.

Option/ Parameter	Default Setting	Possible Settings
RE-EQUALIZER	ON	ON, OFF
LFE MIX	+0.0dB	-10.0dB to +0.0dB
ES DECODING	AUTO	AUTO, ON, OFF
OUTPUT LEVELS	—	—
CUSTOM	—	—

See “Listening Mode Menu Option & Parameter Descriptions” on page 5-29 for detailed descriptions of these options and parameters.

Parameter Setting \ Input Source	5.1-Channel DTS	5.1-Channel Matrix-Encoded DTS-ES	6.1-Channel Discrete-Encoded DTS-ES
ES DECODING: AUTO	DTS THX ULTRA2	DTS-ES THX	DTS-ES THX
ES DECODING: ON	DTS-ES THX	DTS-ES THX	DTS-ES THX
ES DECODING: OFF	DTS THX ULTRA2	DTS THX ULTRA2	DTS THX ULTRA2

The table at the bottom of the previous page indicates the conditions in which THX Ultra2 and DTS-ES decoding are engaged.

- THX Ultra2 decoding is engaged when the ES DECODING parameter is set to OFF or the ES DECODING parameter is set to AUTO and a 5.1-channel DTS source is detected.
- DTS-ES decoding is engaged when the ES DECODING parameter is set to ON or the ES DECODING parameter is set to AUTO and a 5.1-channel matrix-encoded or 6.1-channel discrete-encoded DTS-ES source is detected.
- Listening mode name differs depending on the encoding present in the input source, the ES DECODING parameter setting and the speaker setup.
 - The DTS THX ULTRA2 listening mode is available when THX Ultra2 decoding is engaged.
 - The DTS-ES THX listening mode is available when DTS-ES decoding is engaged.
 - The DTS THX ULTRA2 and DTS(-ES) THX listening modes cannot be activated unless side and rear speakers are present.

dts THX MUSIC

MODE ADJUST ▸ dts THX MUSIC

- Designed for playback of 5.1-channel DTS music sources.
- The DTS THX MUSIC listening mode cannot be activated unless side and rear speakers are present.
- ASA processing is applied to signals sent to the rear speakers. See “ASA” on page 3-32 for more information.
- Recommended for home theaters with THX-certified speaker setups.

Option/ Parameter	Default Setting	Possible Settings
LFE MIX	+0.0dB	-10.0dB to +0.0dB
OUTPUT LEVELS	—	—
CUSTOM	—	—

See “Listening Mode Menu Option & Parameter Descriptions” on page 5-29 for detailed descriptions of these options and parameters.

Note:

The DTS THX MUSIC listening mode can only be activated with the front panel or remote control Mode ▲ and ▼ buttons.

MODE ADJUST ▶

- Designed for playback of 5.1- and 6.1-channel DTS(-ES) sources.
- Decodes 5.1 matrix or 6.1 discrete channels from DTS(-ES) sources. The six main channels are full-frequency. The .1 channel, often referred to as LFE information, has a limited frequency range of 120Hz.
- Appropriate for DTS(-ES) film sources.

Option/ Parameter	Default Setting	Possible Settings
LFE MIX	+0.0dB	-10.0dB to +0.0dB
ES DECODING	AUTO	AUTO, ON, OFF
OUTPUT LEVELS	—	—
CUSTOM	—	—

See "Listening Mode Menu Option & Parameter Descriptions" on page 5-29 for detailed descriptions of these options and parameters.

2-CHAN
MODE ADJUST ▶ **2-CHAN**

- Designed for converting 5.1- or 6.1-channel DTS(-ES) sources into 2-channel Logic 7-encoded output signals.
- Sends downmixed 5.1- or 6.1-channel DTS(-ES) input signals to the front speakers and subwoofer.
- Recommended for recording purposes.

Option/ Parameter	Default Setting	Possible Settings
CENTER MIX	+0dB	-25dB to +5dB
SURROUND MIX	+0dB	-5dB to +5dB
CNTR DLY SAMPLES	+0	-127 to +127
MASTER LEVEL	+0dB	-5dB to +5dB
LFE MIX	+0.0dB	-20.0dB to +0.0dB
ES DECODING	AUTO	AUTO, ON, OFF
SUB LEVEL	+0dB	OFF, -30dB to +12dB
CUSTOM	—	—

See "Listening Mode Menu Option & Parameter Descriptions" on page 5-29 for detailed descriptions of these options and parameters.

5.1a BYPASS

MODE ADJUST ▶ 5.1a BYPASS

- Designed for playback of 5.1-channel analog sources, such as DVD-A or SACD players.
- The 5.1-channel analog input connectors are sent directly to the volume control and audio output connectors. These signals receive no internal processing.
- When both side and rear speakers are present, surround channel signals are sent in parallel to the side and rear speakers. To configure a 5-channel speaker setup, set the OUTPUT LEVELS menu SIDE L/R or REAR L/R parameter to OFF to deactivate the associated surround speakers.
- The 5.1a BYPASS listening mode is automatically activated whenever one of the 5.1-channel analog audio input connectors is assigned to the selected input.
- The 5.1a BYPASS listening mode is the only listening mode available for 5.1-channel analog sources.

Option/ Parameter

OUTPUT LEVELS

CUSTOM

See "Listening Mode Menu Option & Parameter Descriptions" on page 5-29 for detailed descriptions of these options and parameters.

Note:

Speaker crossover settings, speaker distances and audio (tone) controls are not available when the 5.1a BYPASS listening mode is activated.

2CH BYPASS

MODE ADJUST ▶ 2CH BYPASS

- Designed for playback of 2-channel analog sources.
- Analog audio input signals are sent to the audio output connectors labeled Front L/R. These input signals receive no internal processing.
- The 2CH BYPASS listening mode is automatically activated when a 2-channel analog audio source is present and the ADVANCED menu 2-CH ANLG BYP parameter is set to ON.
- The 2CH BYPASS listening mode is not available when the ADVANCED menu INPUT SELECT parameter is set to AUTO and a digital audio source is present.
- No parameters are available for the 2CH BYPASS listening mode.

Note:

Speaker crossover settings, speaker distances and audio (tone) controls are not available when the 2CH BYPASS listening mode is activated.

LISTENING MODE MENU OPTION & PARAMETER DESCRIPTIONS

5 SPKR ENHANCE

ON, OFF

Simulates 7-channel playback in 5-channel speaker configurations. When set to ON, the MC-4 provides an increased sense of spaciousness and envelopment through the surround speakers. This enhancement is most noticeable when the surround speakers are positioned to the side of the primary listening position or when the primary listening position is located against the rear wall. The effectiveness of this parameter varies within the listening space. For best results, it is recommended that you position the surround speakers to the left and right sides of the primary listening position.

ACADEMY FILTER

ON, OFF

When set to ON, restores the proper tonal balance of older mono film sources that have much narrower frequency responses than more recent mono film sources.

AUTO AZIMUTH

ON, OFF

Maximizes matrix steering accuracy. When set to ON, the MC-4 continually monitors the 2-channel input signal and automatically adjusts the relative level and time offset of the input channels to ensure that signals are sent to the appropriate channels with maximum separation. When set to OFF, the accuracy of the selected listening mode varies among sources. It is recommended that you set this parameter to ON for film and broadcast sources and to OFF for music sources.

BASS CONTENT

BINAURL, MONO, STEREO

Adjusts the bass content of binaural, mono and stereo recordings. When set to BINAURL, the MC-4 activates low-frequency compensation. Select this setting for true binaural sources recorded with dummy head microphones. Select the MONO setting for sources recorded with mono bass. Select the STEREO setting for sources recorded with stereo bass.

BASS ENHANCE

ON, OFF

Enhances stereo bass, which results in low-frequency reproduction that is less localizable and more realistic in the listening space. The effectiveness of the BASS ENHANCE parameter varies depending on room acoustics and the ability of the surround speakers to reproduce low frequencies. It is recommended that you use front, side or rear speakers that are capable of reproducing frequencies of 40Hz or lower.

Note:

When the BASS ENHANCE parameter is set to ON, most listening spaces have a 2dB to 3dB reduction in low-frequency energy. It is recommended that you use the AUDIO CONTROLS menu BASS parameter to compensate for this reduction.

CAUTION

When set to ON, the BASS ENHANCE parameter might damage speakers that are not capable of producing low frequencies below 80Hz.

BASS RT 5ms to 48.6s

Works with the MID RT and SIZE parameters to adjust the amount of time required for low-frequency information to decay below 60dB in level. The BASS RT parameter setting should match the MID RT parameter setting for more natural effects in smaller listening spaces.

CAUTION Setting the BASS RT, MID RT and SIZE parameters to a high value may produce undesirable or damaging audio.

CALIBRATION

Opens the PANORAMA listening mode CALIBRATION menu, which can be used to calibrate the PANORAMA listening mode. See "PANORAMA CALIBRATION" on page 5-12 for more information.

CENTER OFF, -30dB to +12dB

MODE ADJUST ▶ **(Listening Mode)** ▶ **OUTPUT LEVELS** ▶ **CENTER**

Controls the output level of the audio output connector labeled Center.

CENTER DEPTH 0 to 18

Adjusts the amount of processing applied to the center channel, changing the perceived distance of the center speaker. Higher settings increase and lower settings decrease the perceived distance of the center speaker from the listening position.

CENTER MIX -25dB to +5dB

Indicates the relative center channel level for downmixing. It is recommended that you set this parameter to +0dB for film sources and -5dB for music sources.

CNTR DLY SAMPLES -127 to +127

Controls the relative time offset of the center channel. It is recommended that you set this parameter to +0 unless the center channel is not properly timed and the value of the error is known.

COMPRESSION AUTO, ON, OFF

Reduces wide volume level changes and increases dialog intelligibility at lower listening levels for Dolby Digital input sources. When set to ON, full compression is applied regardless of volume level. When set to OFF, compression is not applied. It is recommended that you set this parameter to AUTO or ON for Dolby Digital input sources that are listened to at lower volume levels, especially for nighttime viewing to avoid disturbing others.

CTR WIDTH MIN, 1 to 6, MAX

Adjusts the center image. When set to MIN, the center image is heard from just the center speaker. When set to MAX, the center image is heard from just the front left and right speakers as a "phantom" center image. When set on the 1 to 6 scale, the center image is heard in various combinations of the front and center speakers.

CUSTOM

MODE ADJUST ▶ **(Listening Mode)** ▶ **CUSTOM**

Opens the CUSTOM menu, which can be used to compare custom and factory-default versions of the selected listening mode and to restore the factory default version of the selected listening mode.

CUSTOM VS PRESET

MODE ADJUST ▶ **(Listening Mode)** ▶ **CUSTOM** ▶ **CUSTOM VS PRESET**

Allows comparison listening to the custom and factory-default versions of the selected listening mode. When PRESET is selected, the listening mode is heard in its factory-default condition – as if all parameters had been restored to their factory-default settings. No parameter settings are affected when this option is selected. The listening mode will revert to its modified condition when the CUSTOM VS PRESET option is closed.

When CUSTOM is selected, the listening mode is heard in its custom condition – with all of its current parameter settings. The CUSTOM option is available even when no parameter settings have been adjusted. However, the PRESET and CUSTOM options will sound identical until adjustments are made.

To toggle between the factory-default and modified versions of the selected listening mode:

1. Follow the CUSTOM VS PRESET menu path to open the CUSTOM VS PRESET drop-down menu.
2. When the CUSTOM VS PRESET drop-down menu opens, press the Menu ▲ and ▼ arrows to toggle between the PRESET (factory-default) and CUSTOM (customized) versions of the selected listening mode.
3. When finished, press the Menu ◀ arrow to close the CUSTOM VS PRESET menu.
4. Press the Menu ◀ arrow to close the CUSTOM menu and return to the listening mode menu.

DIMENSION

FRONT, NEUTRAL, REAR

Controls the relative balance of the sound field, which can be useful with certain recordings to achieve a more suitable balance among all speakers. When set to FRONT, the sound field is balanced toward the front of the listening space. When set to NEUTRAL, the sound field is balanced at the center of the listening space. When set to REAR, the sound field is balanced toward the rear of the listening space.

EFFECT LVL

–12dB to +6dB

Adjusts the amount of effect applied to the listening mode.

ES DECODING

AUTO, ON, OFF

Controls the DTS-ES decoding feature, which can be used to extract a rear channel from DTS sources.

- When set to ON, DTS-ES decoding is engaged for all DTS(-ES) sources.
- When set to OFF, DTS-ES decoding is not engaged for all DTS(-ES) sources.
- When set to AUTO, DTS-ES decoding is engaged when a 5.1-channel matrix-encoded or 6.1-channel discrete-encoded DTS-ES source is detected. DTS-ES decoding is not engaged when a 5.1-channel DTS source is detected.

DTS-ES listening modes are available when DTS-ES decoding is engaged. DTS listening modes are available when DTS-ES decoding is not engaged. DTS-ES decoding cannot be engaged unless both side and rear speakers are present. See “SPEAKER SETUP” on page 3-24 for additional information.

When the Shift 1 command bank is activated, pressing the remote control DTS button while a DTS(-ES) input source is present toggles the ES DECODING parameter, cycling through the AUTO, ON and OFF settings.

Note:

The DTS(-ES) STATUS menu includes the SB level meter when:

- *The ES DECODING parameter is set to ON and a 5.1-channel DTS source is present.*
- *The ES DECODING parameter is set to AUTO and a 5.1-channel matrix-encoded or 6.1-channel discrete-encoded DTS-ES source is present.*

EX DECODING

AUTO, ON, OFF

Controls the Dolby Digital Surround EX decoding feature, which can be used to extract a rear channel from 5.1-channel Dolby Digital sources.

- When set to ON, Dolby Digital Surround EX decoding is engaged for all 5.1-channel Dolby Digital sources.
- When set to OFF, Dolby Digital Surround EX decoding is not engaged for all 5.1-channel Dolby Digital sources.
- When set to AUTO, Dolby Digital Surround EX decoding is engaged when a flagged 5.1-channel Dolby Digital source recorded with Surround EX is detected. Dolby Digital Surround EX decoding is not engaged when a non-flagged 5.1-channel Dolby Digital source recorded with or without Surround EX is detected.

- The MC-4 cannot automatically detect Dolby Digital Surround EX encoding in non-flagged 5.1-channel Dolby Digital sources. A non-flagged 5.1-channel Dolby Digital source does not include information in the input signal that identifies Dolby Digital Surround EX encoding.

The DOLBY DIGITAL EX listening mode is available when Dolby Digital Surround EX decoding is engaged. The DOLBY DIGITAL listening mode is available when Dolby Digital Surround EX decoding is not engaged. Dolby Digital Surround EX decoding cannot be engaged unless both side and rear speakers are present. See "SPEAKER SETUP" on page 3-24 for more information.

When the Shift 1 command bank is activated, pressing the remote control DOLBY button while a 5.1-channel Dolby Digital input source is present activates the DOLBY DIGITAL EX or DOLBY DIGITAL listening mode. Subsequent presses toggle the EX DECODING parameter, cycling through the AUTO, ON and OFF settings.

FRONT STEERING

OFF, MSURR, MUSIC, FILM

Adjusts front steering between the front left, front right and center speakers. When set to FILM, maximum front steering is applied to the center channel. When set to MUSIC, moderate front steering is applied. When set to MSURR, minimum front steering is applied. When set to OFF, no front steering is applied. It is recommended that you set this parameter to FILM for film and broadcast sources and to MUSIC, MSURR or OFF for music sources.

INPUT BALANCE

L< to <|> to >R

Controls the balance of the selected stereo analog audio input connectors, compensating for audio input sources with audible channel imbalance.

LFE MIX –20.0dB or –10.0dB to +0.0dB

Controls the output level of LFE information – the .1 channel in a 5.1- or 6.1-channel input source – that is sent to the audio output labeled Subwoofer. Low frequencies from up to seven other channels might be combined with the LFE information to create the subwoofer output signal, which significantly increases subwoofer output levels. Careful adjustment of this parameter allows achievement of proper tonal balance and reduces the risk of subwoofer overload. When the speaker setup does not include a subwoofer, LFE information is mixed into speakers for which the corresponding CUSTOM SETUP menu parameter is set to FULL or to the lowest crossover points.

LISTENER POS –127 to +127

See “PANORAMA CALIBRATION” on page 5-12 for more information.

LIVENESS 30ms to 20.2s

Depends on the SIZE parameter setting. The LIVENESS parameter adjusts the amount of effect recirculation. Higher settings mimic more reflective surfaces and increase decay time.

LOW FREQ WIDTH –25dB to +25dB

Applies low-frequency spatial correction to the input signal. This correction is applied to uncorrelated input signals below 60Hz.

MASTER LEVEL –5dB to +5dB

Adjusts the output level of 2-channel Logic 7-encoded sources.

MID RT 24ms to 24.3s

Works with the BASS RT and SIZE parameters to adjust the amount of time required for mid-frequency information to decay below 60dB in level.

CAUTION Setting the BASS RT, MID RT or SIZE parameters to a high value may produce undesirable or damaging audio.

OUTPUT LEVELS

MODE ADJUST ▶ **(Listening Mode)** ▶ **OUTPUT LEVELS**

Opens the OUTPUT LEVELS menu, which can be used to adjust output levels for the audio output connectors labeled Center, Sub, Side L/R and Rear L/R. The OUTPUT LEVELS option does not appear on listening mode menus when the listening mode does not accommodate multichannel output signals. Instead, an output-specific parameter appears. For instance, the Mono listening mode menu includes a SUB LEVEL parameter.

Option/ Parameter	Default Setting	Possible Settings
CENTER	+0dB	OFF, –30dB to +12dB
SIDE L/R	+0dB	OFF, –30dB to +12dB
REAR L/R	+0dB	OFF, –30dB to +12dB
SUB	+0dB	OFF, –30dB to +12dB

PANORAMA ON, OFF

When set to ON, extends the front stereo image to include surround channel signals, which creates a “wraparound” effect with side wall imaging.

Note:

The DOLBY PLII MUSIC listening mode PANORAMA parameter should not be confused with the separate PANORAMA listening mode.

PRE-DELAY OFF, 1ms to 100ms

Adjusts delay time between the direct sound and the onset of reverberation. Higher settings make the simulated space sound larger. Because some pre-delay is inherent in all source material, it is recommended to begin with the parameter set to OFF, then make adjustments accordingly.

RE-EQUALIZER ON, OFF

Simulates high-frequency rolloffs that occur in movie theaters. When set to ON, the MC-4 applies a high-frequency filter. When set to OFF, the MC-4 does not apply a high-frequency filter. It is recommended that you set this parameter to ON for film sources, as many films are mixed for movie theaters and might sound too bright when played back in home theaters without re-equalization.

REAR DLY OFFSET OFF, 1ms to 30ms

Increases the perceived depth of the listening space by delaying the arrival time of rear speaker signals. It is recommended that you increase the setting when using side and rear speakers that are located close together or when a greater sense of depth is desired in the listening space.

REAR L/R OFF, -30dB to +12dB

MODE ADJUST ▶ (Listening Mode) OUTPUT LEVELS ▶ REAR L/R

Controls the output level of the audio output connector labeled Rear L/R.

RESET MODE

MODE ADJUST ▶ (Listening Mode) ▶ CUSTOM ▶ RESET MODE

Restores the factory-default version of the selected listening mode, restoring all listening mode menu parameters to their factory-default settings.

To restore the factory-default version of the selected listening mode:

1. Follow the RESET MODE menu path. The PRESS RIGHT → TO RESTORE MODE drop-down message.
2. When the drop-down message opens, press the Menu ▶ arrow to restore the factory-default version of the selected listening mode and close the message. Press the Menu ◀ arrow to close the message without restoring the factory-default version of the selected listening mode.

3. Press the Menu ◀ arrow to close the CUSTOM menu and return to the listening mode menu.

Note:

When the CUSTOM menu RESET MODE option is selected to restore the factory-default version of the selected listening mode, the corresponding TRIGGER SETUP menu listening mode parameter is automatically set to OFF.

ROLLOFF 500Hz to 20.0kHz, OFF

Simulates the absorption of high frequencies in a real space. It is recommended that you begin with a low setting to simulate high-frequency absorptive spaces.

SIDE L/R OFF, -30dB to +12dB

MODE ADJUST ▶ **(Listening Mode)** ▶ **OUTPUT LEVELS** ▶ **SIDE L/R**

Controls the output level of the audio output connector labeled Side L/R.

SIZE 4m to 20m or 30m

Adjusts the length of the listening space within a 4m to 20m or 30m range (depending on the listening mode). Increase the size of the space to increase the reverb effect.

CAUTION

Setting the BASS RT, MID RT and SIZE parameters to a high value may produce undesirable or damaging audio.

SOUND STAGE FRONT, NEUTRAL, REAR

Dynamically controls the relative balance of the audio output connectors. When set to FRONT, Side L/R and Rear L/R output levels are attenuated by 6dB, shifting the perceived balance of the sound field to the front of the listening space. When set to NEUTRAL, Side L/R and Rear L/R output levels are slightly attenuated by 3dB, shifting the perceived balance of the sound field to the center of the listening space. When set to REAR, Side L/R and Rear L/R output levels are not attenuated, preserving the intended balance of the sound field.

SOURCE RIGHT, LEFT & RIGHT, LEFT

See "PANORAMA CALIBRATION" on page 5-12 for more information.

SPEAKER ANGLE 10deg to 90deg

See "PANORAMA CALIBRATION" on page 5-12 for more information.

SPEECH DETECT ON, OFF

Distinguishes monaural speech from other input sources. When set to ON, effects are lowered to minimize interference and unnatural echo in monaural speech. When stereo input sources are present, the front left and right channels are independently used as inputs for ambience synthesis. When strong monaural speech is present in the input source, the monaural component of the ambience effect is reduced and the stereo component of the effect is increased. When set to OFF, the amount of ambience synthesis is dynamically controlled.

SUB LEVEL OFF, -30dB to +12dB

Controls the output level of the audio output connector labeled Subwoofer. The SUB LEVEL parameter appears on listening mode menus when the listening mode does not accommodate multi-channel output signals.

SUBWOOFER OFF, -30dB to +12dB

MODE ADJUST ▶ **(Listening Mode)** ▶ **OUTPUT LEVELS** ▶ **SUBWOOFER**

Controls the output level of the audio output connector labeled Subwoofer.

SURR ROLLOFF 500Hz to 20.0kHz, OFF

Applies high-frequency attenuation control to the audio output connectors labeled Side L/R and Rear L/R. This filter is only applied to output signals generated by the MC-4.

SURROUND DLY 0ms to 15ms

Increases the perceived depth of the listening space by delaying the arrival time of signals from the side and rear speakers. It is recommended that you increase the setting when a greater sense of depth is desired in the listening space.

SURROUND EX AUTO, ON, OFF

Controls the THX Surround EX decoding feature, which can be used to extract a rear channel from 5.1-channel Dolby Digital sources.

- When set to ON, THX Surround EX decoding is engaged for all 5.1-channel Dolby Digital sources.
- When set to OFF, THX Surround EX decoding is not engaged for all 5.1-channel Dolby Digital sources.
- When set to AUTO, THX Surround EX decoding is engaged when a flagged 5.1-channel Dolby Digital source with THX Surround EX encoding is detected. THX Surround EX decoding is not engaged when a non-flagged 5.1-channel Dolby Digital source with or without THX Surround EX encoding is detected.
- The MC-4 cannot automatically detect THX Surround EX encoding in non-flagged 5.1-channel Dolby Digital sources. A non-flagged source does not include information in the input signal that identifies THX Surround EX encoding.

The THX SurEX listening mode is available when THX Surround EX decoding is engaged. The THX and THX ULTRA2 listening modes are available when THX Surround EX decoding is not engaged. THX Surround EX decoding cannot be engaged unless both side and rear speakers are present. See "SPEAKER SETUP" on page 3-24 for more information.

When the Shift 1 command bank is activated, pressing the remote control THX button while a 5.1-channel Dolby Digital input source is present activates the THX, THX ULTRA2 or THX SurEX listening mode.

Note:

Toggling the SURROUND EX parameter setting produces low-level clicks in the front speakers.

SURROUND MIX

–5dB to +5dB

Controls the relative level of surround channel information sent to the audio output connectors labeled Front L/R. It is recommended that you set this parameter to +2dB or +3dB for all input sources.

VOCAL ENHANCE

+6.0dB, +3.0dB, +0.0dB

Controls the level of dialog boost in the audio output connector labeled Center. Increase this setting to improve dialog intelligibility, particularly at lower volume levels.

6

Troubleshooting & Maintenance

Troubleshooting.	6-2
Routine Maintenance	6-3
Restoring Factory-Default Settings.	6-4

TROUBLESHOOTING

The MC-4 does not power on.

1. Attempt to power on the MC-4 with the front panel **Standby** button and remote control **On** button.
2. Make sure the rear panel power switch is set to the **O** (on) position.
3. Examine the power cord to ensure a good connection between the rear panel AC input connector and the wall outlet.
4. Check the electrical circuit and breaker.

The remote control does not work.

1. Make sure the front panel IR receiver window shown on page 2-3 is not obstructed. The remote control must be in line of sight with the receiver for proper operation. See page 2-7 for more information.
2. Make sure the remote control batteries are correctly inserted with the proper polarity. See page 1-5 for instructions to install new batteries.

The MC-4 is powered on, but there is no audio.

1. Examine the audio cables to ensure a good connection to the associated amplifier.
2. Make sure volume level is audible. Volume level can be increased with the front panel volume knob (page 2-3) or the remote control VOL ▲ and ▼ buttons (page 2-14).

3. Make sure audio has not been muted. The message MUTE ON or FULL MUTE ON will appear in the on-screen and front panel displays when audio has been muted. To deactivate mute, press the front panel or remote control **Mute** button or use the front panel volume knob or the remote control VOL ▲ and ▼ buttons to adjust volume level.
4. Check the INPUT SETUP menu DIGITAL IN and ANALOG IN parameters to ensure the appropriate audio connector is assigned to the selected input. See page 3-6 for more information.
5. Make sure the MC-4 is receiving an audio signal. To do this, follow the instructions that begin on page 2-14 to open the STATUS menu for the current input source.
6. Make sure all associated power amplifiers are powered on.

Dialog sounds muffled.

1. If the speaker setup does not include a center speaker, make sure a custom – as opposed to a THX – speaker setup is selected.
2. Make sure the CUSTOM SETUP menu CENTER parameter is set to NONE (page 3-27).

A humming sound is present in the audio.

1. If a cable TV connection is present, disconnect the cable from the wall outlet. If this eliminates the humming sound, a ground loop isolation device is required. Contact your dealer or the cable provider for assistance.
2. Disconnect components one at a time to isolate the problem. Once the problem is identified, make sure the associated component is properly grounded and connected to the same

electrical circuit as the MC-4.

The MC-4 is powered on, but there is no video.

1. Examine the video cables – particularly the S-video cables – to ensure a good connection to the associated component.
2. Check the INPUT SETUP menu VIDEO IN (page 3-11) and COMPONENT IN (page 3-12) parameters to ensure the appropriate video connector is assigned to the selected input.

RF interference is present in the audio or video.

1. Make sure the MC-4 is not positioned near unshielded TV or FM antennas, cable TV decoders and other RF-emitting devices.
2. Replace unshielded cables with shielded cables wherever possible.

The MC-4 is exhibiting erratic behavior.

1. Set the rear panel power switch to the I (off) position. Wait 10 seconds. Then set the rear panel power switch to the O (on) position.
2. Document all user-defined settings on the installation worksheet that begins on page A-14. Then, follow the instructions on the next page to restore factory-default settings.

If all else fails . . .

1. Set the rear panel power switch to the I (off) position. Wait 10 seconds. Then set the rear panel power switch to the O (on) position.

2. Document all user-defined settings on the installation worksheet that begins on page A-14. Then follow the instructions on the next page to restore factory-default settings.
3. Contact an authorized Lexicon dealer.
4. Contact Lexicon customer service at 781-280-0300 or www.lexicon.com.

Note:

Visit the knowledge base at www.lexicon.com/kbase for answers to frequently asked questions and additional troubleshooting information.

ROUTINE MAINTENANCE

The bulleted items below describe routine maintenance that should be performed on a periodic basis.

- Clean the MC-4 exterior surface with a soft, lint-free cloth. Do not use alcohol, benzene, acetone-based cleaners or strong commercial cleaners. Do not use a cloth made with steel wool or metal polish. If the MC-4 is exposed to a dusty environment, a low-pressure blower can be used to remove dust from its exterior surface.
- Replace the remote control batteries as needed. The remote control requires two AA batteries. When these batteries are low on power, the remote control enters a low-voltage condition that prevents it from operating the MC-4. When this occurs, follow the instructions on page 1-5 to replace the batteries. Normal operation will resume when new batteries are installed.

RESTORING FACTORY-DEFAULT SETTINGS

When factory-default settings are restored, all parameters and user-defined values are restored to their factory-default settings. Before restoring factory-default settings, it is recommended that you record all user-defined settings on the installation worksheet that begins on page A-14.

To restore factory-default settings:

1. Record all user-defined settings on the installation worksheet that begins on page A-14. When factory-default settings are restored, all parameters and user-defined values are restored to their factory-default settings.
2. If the MC-4 is powered on, press the front panel **Standby** button or the remote control **Off** button to activate standby mode and deactivate the MC-4. If the MC-4 is in standby mode, proceed to step 3.
3. Press the front panel **Standby** button or the remote control **On** button to deactivate standby mode and activate the MC-4.
4. Quickly press and hold the front panel or remote control **Mute** button until the **FACTORY SETTINGS** menu shown below opens in the on-screen and front panel displays.



The **Mute** button must be pressed within 2 seconds of activating the MC-4. If the message MUTE ON appears in the on-screen and front panel displays when the **Mute** button is pressed, too much time has passed. If this occurs, begin again with step 2.

5. Press the remote control Menu **▲** and **▼** arrows to highlight the desired option. Highlight the **RESTORE DEFAULTS** option to restore factory-default settings. Highlight the **EXIT** option to close the **FACTORY SETTINGS** menu without restoring factory-default settings.
6. When the desired option is highlighted, press the Menu **▶** arrow to select this option.
 - If you selected the **RESTORE DEFAULTS** option, the **FACTORY SETTINGS** message shown below appears in the on-screen and front panel displays. When this message appears, press a front panel or remote control button to restart the MC-4.



- If you selected the **EXIT** option, the **FACTORY SETTINGS** menu will close and the two-line status (page 2-14) opens in the on-screen and front panel displays.

A

Appendix

Specifications	A-2
Declaration of Conformity	A-4
Menu Tree	A-4
Installation Worksheet	A-14

SPECIFICATIONS

Audio Input & Output Connectors	
Analog Audio Inputs	8 stereo (RCA) or 5 stereo and one 5.1-channel or 2 stereo and two 5.1-channel connectors
Digital Audio Inputs	<ul style="list-style-type: none"> • 4 S/PDIF coaxial (RCA) and 4 S/PDIF optical (TosLink) connectors • Coaxial and optical input connectors conform to IEC-958, S/PDIF standards • Accepts 44.1, 48, 88.2 and 96kHz sample rates • Accepts 16–24 bits PCM audio, Dolby Digital, DTS and DTS-ES discrete data formats
Audio Outputs	8 unbalanced (RCA) connectors for Front L/R, Center, Subwoofer, Side L/R and Rear L/R

Audio Performance	
A/D Conversion	24-bit, 96kHz, dual-bit $\Delta\Sigma$ architecture
D/A Conversion	24-bit, 44.1 to 192kHz, multi-bit $\Delta\Sigma$ architecture
Frequency Response	10Hz to 20kHz, +0.05dB/–0.1dB, –0.5dB at 40kHz, reference 1kHz
THD + Noise	Below 0.008% at 1kHz, maximum output level
Dynamic Range	108dB minimum, 22kHz bandwidth
Signal-to-Noise Ratio	108dB minimum, 22kHz bandwidth
Input Sensitivity	200mVrms (2Vrms for maximum output level) at 0dB input gain
Input Impedance	100k Ω in parallel with 150pF
Output Level	<ul style="list-style-type: none"> • 150mVrms typical, 6Vrms maximum • Maximum value with full-scale input signal and volume at +12dB
Output Impedance	100 Ω in parallel with 150pF

Video Input & Output Connectors	
Video Inputs	5 composite (RCA), 5 S-video and 3 component video (RCA)
Video Outputs	1 composite (RCA), 1 S-video and 1 component (RCA)

Composite & S-video Performance	
Compatibility	NTSC, PAL and SECAM
Switching	Active
Output Level	1.0V peak-to-peak
Impedance	75 Ω
Input Return Loss	>40dB
Differential Gain	<0.5%
Differential Phase	<0.5°
Bandwidth	>25MHz
K Factor	<0.3%
Gain	± 0.15 dB
Signal-to-Noise Ratio	>65dB
Frequency Response	10Hz to 10MHz + 0.1/–0.3dB

Component Video Performance	
Compatibility	3-channel (Y, Pr, Pb), format-independent
Switching	Passive
Impedance	75Ω
Insertion Loss	<3dB
Bandwidth	>150MHz

Other	
Trigger Outputs	1 power on/off and 1 programmable connector on detachable screw terminals (+12 VDC, 0.5 amps each)
RS-232 Serial Input/Output	2 9-pin D-sub connectors
Power Requirements	90–250 VAC, 50–60Hz, 60W (universal line input), detachable power cord
MC-4 Dimensions & Weight	<ul style="list-style-type: none"> • Height (with feet): 3.81 inches (97mm) • Width: 17.3 inches (440mm) • Depth: 14.85 inches (377mm) • Weight: 17lbs (7.6kg)
Rack Mounting	Optional brackets are available for installation in a standard 19-inch equipment rack (2 rack units required for MC-4).
Environment	<ul style="list-style-type: none"> • Operating Temperature: 0° to 35°C (32° to 95°F) • Storage Temperature: –30° to 75°C (–22° to 167°F) • Relative Humidity: 95% maximum without condensation
Remote Control	<ul style="list-style-type: none"> • Hand-held, backlit infrared remote control unit • Requires 2 AA batteries (Alkaline batteries recommended)

Specifications are subject to change without notice.

DECLARATION OF CONFORMITY**Application of Council Directive(s):**

89/336/EEC and 93/68/EEC

Standard(s) to Which Conformity is Declared:

EN55022:1994 + A1:1995 + A2:1997, EN55024:1998,
EN61000-3-2: 2000, EN61000-3-3:2000 and
EN60065: 1998

Manufacturer: Harman Specialty Group
3 Oak Park
Bedford, MA 01730-1413 USA

The equipment identified here conforms to the Directive(s)
and Standard(s) specified above.

Type of Equipment: Digital Controller

Model: Lexicon MC-4

Date: July 2004

**Harman Specialty Group
Vice President of Engineering
3 Oak Park
Bedford, MA 01730-1413 USA
Tel: 781-280-0300
Fax: 781-280-0490**

MENU TREE

The menu tree that begins on the next page is based on Software
Version 1.0.

Menu Tree (continued from page A-5)

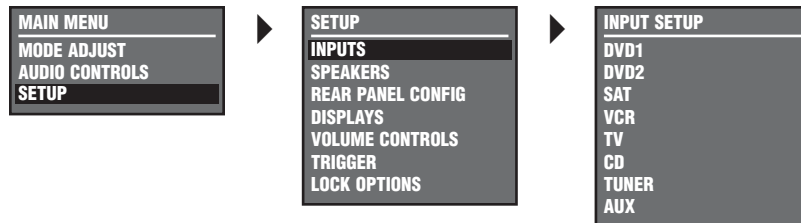

Selecting the **SETUP** menu **INPUTS** option prompts the selection of the desired input (e.g., DVD1). Selecting an input opens the corresponding **INPUT SETUP** menu shown below. The parameters on the left side of the **INPUT SETUP** menus are identical regardless of which input is selected. The parameter settings on the right side are adjustable. Default parameter settings differ from input to input. The **INPUT SETUP** menus shown below indicate default parameter settings for each input.

continued from page A-5

DVD1 INPUT SETUP	
NAME	DVD1
DIGITAL IN	COAX-1
ANALOG IN	NONE
ANLG IN LVL	AUTO
VIDEO IN	S-VIDEO-1
COMPONENT IN	1
2-CH	[] FILM
D/D	5.1 [] FILM
[] []	[] [] FILM
ADVANCED	

SAT INPUT SETUP	
NAME	SAT
DIGITAL IN	OPTICAL-1
ANALOG IN	ANALOG-1
ANLG IN LVL	AUTO
VIDEO IN	S-VIDEO-3
COMPONENT IN	3
2-CH	[] TV
D/D	5.1 [] TV
[] []	[] [] FILM
ADVANCED	

TV INPUT SETUP	
NAME	TV
DIGITAL IN	OPTICAL-2
ANALOG IN	ANALOG-3
ANLG IN LVL	AUTO
VIDEO IN	S-VIDEO-5
COMPONENT IN	NONE
2-CH	[] TV
D/D	5.1 [] TV
[] []	[] [] FILM
ADVANCED	

TUNER INPUT SETUP	
NAME	TUNER
DIGITAL IN	NONE
ANALOG IN	ANALOG-4
ANLG IN LVL	AUTO
VIDEO IN	NONE
COMPONENT IN	NONE
2-CH	[] MUSIC
D/D	5.1 [] MUSIC
[] []	[] [] MUSIC
ADVANCED	

DVD2 INPUT SETUP	
NAME	DVD2
DIGITAL IN	COAX-2
ANALOG IN	NONE
ANLG IN LVL	AUTO
VIDEO IN	S-VIDEO-2
COMPONENT IN	2
2-CH	[] FILM
D/D	5.1 [] FILM
[] []	[] [] FILM
ADVANCED	

VCR INPUT SETUP	
NAME	VCR
DIGITAL IN	NONE
ANALOG IN	ANALOG-2
ANLG IN LVL	AUTO
VIDEO IN	S-VIDEO-4
COMPONENT IN	NONE
2-CH	[] FILM
D/D	5.1 [] FILM
[] []	[] [] FILM
ADVANCED	

CD INPUT SETUP	
NAME	CD
DIGITAL IN	COAX-3
ANALOG IN	NONE
ANLG IN LVL	AUTO
VIDEO IN	COMPOSITE-1
COMPONENT IN	NONE
2-CH	[] MUSIC
D/D	5.1 [] MUSIC
[] []	[] [] MUSIC
ADVANCED	

AUX INPUT SETUP	
NAME	AUX
DIGITAL IN	OPTICAL-3
ANALOG IN	NONE
ANLG IN LVL	AUTO
VIDEO IN	COMPOSITE-2
COMPONENT IN	NONE
2-CH	[] MUSIC
D/D	5.1 [] MUSIC
[] []	[] [] MUSIC
ADVANCED	

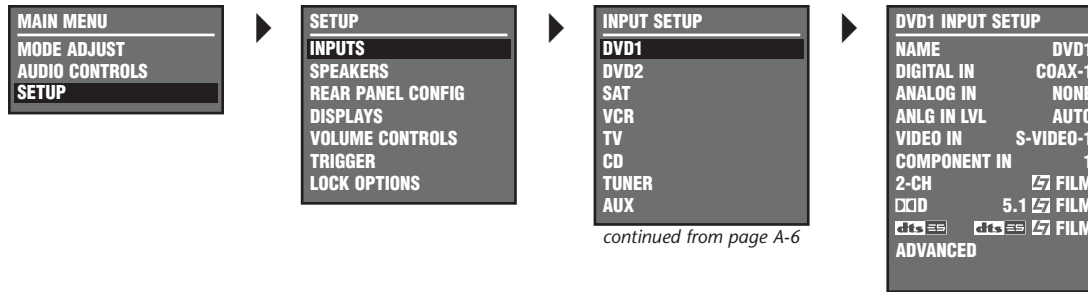

continued from page A-6

Selecting an INPUT SETUP menu item opens the corresponding menu shown below. These menus are identical regardless of which input is selected. The DVD1 INPUT SETUP menu is shown to the left as an example. Whenever it appears, any other INPUT SETUP menu shown on the previous page may be substituted.

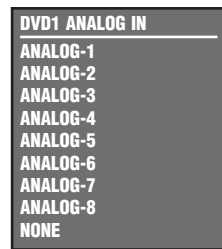
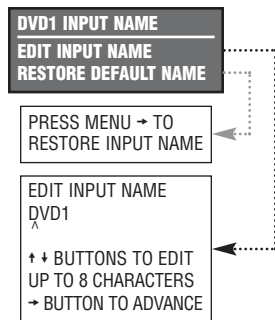

The appearance of the ANALOG IN menu depends on the configuration of the analog audio input connectors. Refer to page 3-8 for more information.

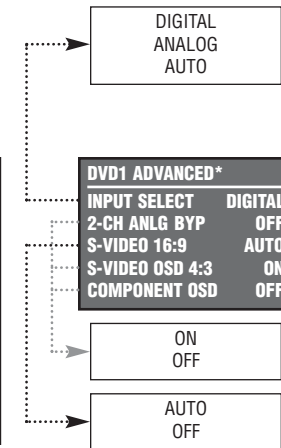
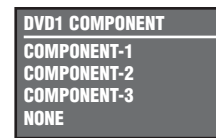

Selecting the INPUT SETUP menu ADVANCED option opens the ADVANCED menu shown above. The parameters on the left side of this menu are adjustable regardless of which input is selected. The settings on the right side are adjustable. Default parameter settings differ from input to input. The ADVANCED menu shown above indicates the default parameter settings for the DVD1 input. The ADVANCED menus shown on page 3-17 indicate default parameter settings for each input.

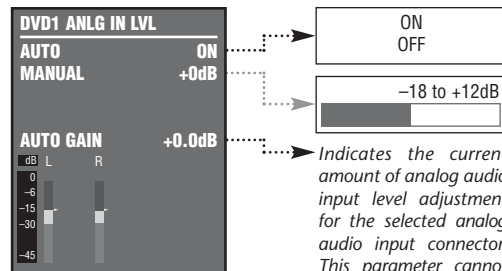
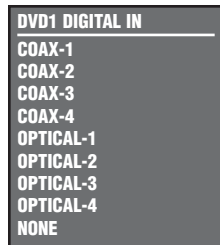

Indicates the current amount of analog audio input level adjustment for the selected analog audio input connector. This parameter cannot be adjusted.

Menu Tree (continued from page A-7)

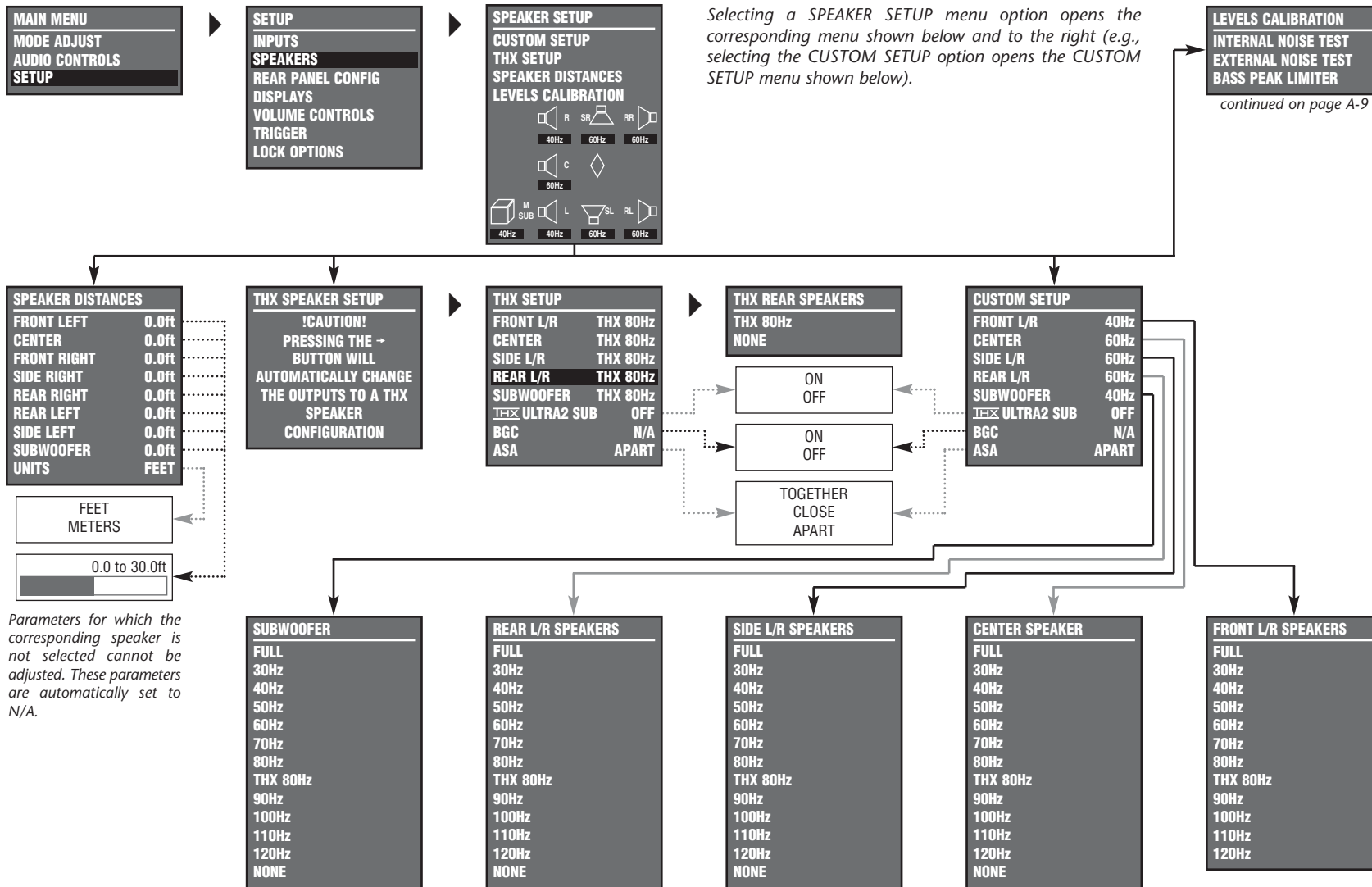

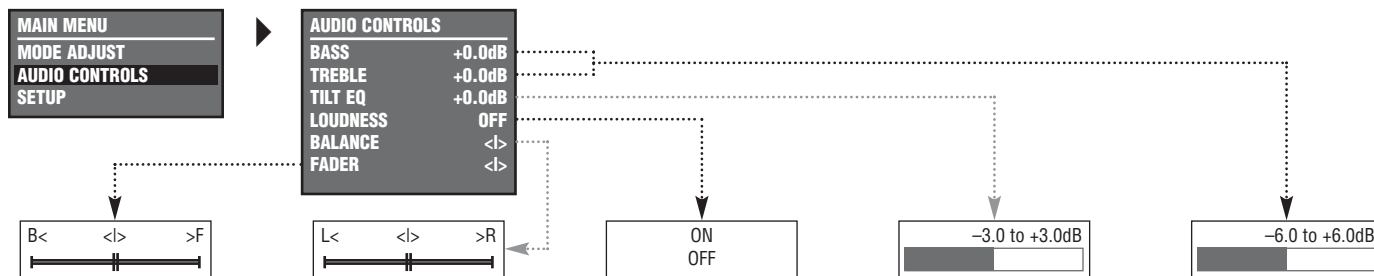
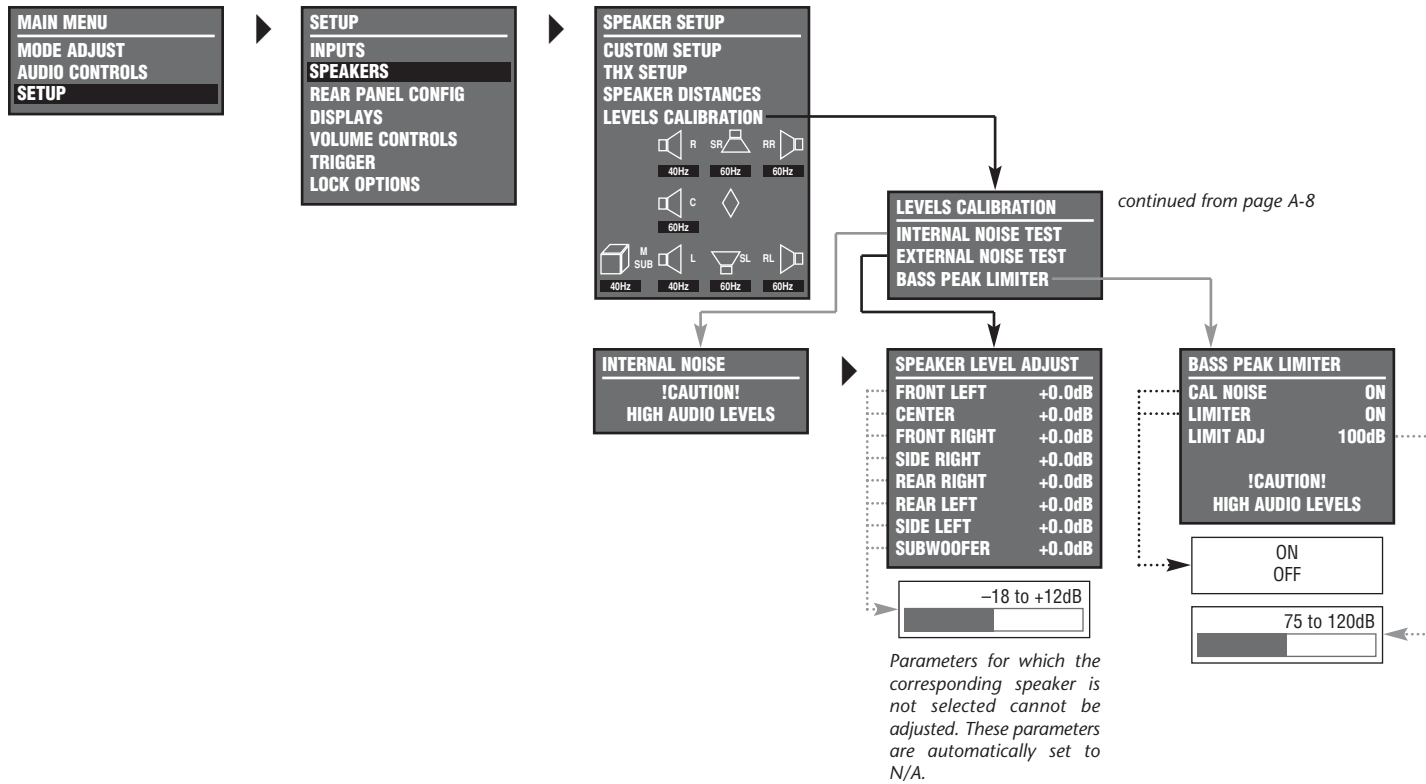

Menu Tree (continued from page A-9)

MAIN MENU	MODE ADJUST
MODE ADJUST	<ul style="list-style-type: none"> ◀ FILM ◀ TV ◀ MUSIC ◀ MUSIC SURR ◀ DOLII + THX ◀ DOLII MOVIE ◀ DOLII MUSIC ◀ DOL + THX ◀ DOLPRO LOGIC ◀ DTS + THX ◀ DTS CIN ◀ DTS MUSIC ◀ NIGHTCLUB ◀ CONCERT HALL ◀ CHURCH ◀ CATHEDRAL ◀ PANORAMA ◀ 2-CH SURROUND ◀ 2-CHANNEL ◀ MONO LOGIC ◀ MONO SURROUND ◀ MONO 5.1 ◀ FILM 5.1 ◀ TV 5.1 ◀ MUSIC THX Sur EX* THX MUSIC DODIGITAL EX* 5.1 2-CHANNEL 5.1 MONO LOGIC 5.1 MONO SURR 5.1 MONO DTS ◀ FILM* DTS ◀ MUSIC* DTS THX* THX MUSIC DTS * DTS 2-CHAN* 5.1a BYPASS 2CH BYPASS

* These listening mode names differ depending on the input source, the speaker configuration and certain parameter settings.

Refer to the Listening Mode Descriptions section that begins on page 5-3 for more information.

Selecting a MODE ADJUST menu listening mode opens the corresponding listening mode menu shown below and on the next page. The parameters on the left side of these menus differ from listening mode to listening mode. The settings on the right side are adjustable. The listening mode menus shown below and on the next page indicate default parameter settings for each listening mode. All listening mode menu parameter drop-down menus are shown on pages A-12 and A-13. The OUTPUT LEVELS, CUSTOM and PANORAMA CALIBRATION menus are shown on page A-12.

◀ FILM	
AUTO AZIMUTH	ON
VOCAL ENHANCE	+0.0dB
RE-EQUALIZER	ON
SOUND STAGE	REAR
5 SPKR ENHANCE	ON
BASS ENHANCE	OFF
SURR ROLLOFF	7.0kHz
REAR DLY OFFSET	15ms
OUTPUT LEVELS	CUSTOM

◀ TV	
AUTO AZIMUTH	ON
VOCAL ENHANCE	+0.0dB
FRONT STEERING	FILM
RE-EQUALIZER	OFF
SOUND STAGE	REAR
5 SPKR ENHANCE	ON
BASS ENHANCE	OFF
SURR ROLLOFF	7.0kHz
REAR DLY OFFSET	15ms
OUTPUT LEVELS	CUSTOM

◀ MUSIC	
VOCAL ENHANCE	+0.0dB
FRONT STEERING	MUSIC
SOUND STAGE	NEUTRAL
5 SPKR ENHANCE	ON
BASS ENHANCE	OFF
SURR ROLLOFF	7.0kHz
REAR DLY OFFSET	15ms
OUTPUT LEVELS	CUSTOM

◀ MUSIC SURR	
VOCAL ENHANCE	+0.0dB
FRONT STEERING	MSURR
SOUND STAGE	NEUTRAL
5 SPKR ENHANCE	ON
BASS ENHANCE	OFF
SURR ROLLOFF	7.0kHz
REAR DLY OFFSET	15ms
OUTPUT LEVELS	CUSTOM

◀ DOLII + THX	
RE-EQUALIZER	ON
OUTPUT LEVELS	CUSTOM

◀ DOLII MOVIE	
OUTPUT LEVELS	CUSTOM

◀ DOLII MUSIC	
PANORAMA	OFF
CTR WIDTH	3
DIMENSION	NEUTRAL
SURROUND DLY	10ms
OUTPUT LEVELS	CUSTOM

◀ DOL + THX	
RE-EQUALIZER	ON
OUTPUT LEVELS	CUSTOM

◀ DOLPRO LOGIC	
OUTPUT LEVELS	CUSTOM

◀ DTS + THX	
RE-EQUALIZER	ON
OUTPUT LEVELS	CUSTOM

◀ DTS CIN	
OUTPUT LEVELS	CUSTOM

◀ DTS MUSIC	
OUTPUT LEVELS	CUSTOM

◀ 2-CH SURROUND	
OUTPUT LEVELS	CUSTOM

◀ 2-CHANNEL	
SUB LEVEL	+0dB
OUTPUT LEVELS	CUSTOM

◀ MONO LOGIC	
EFFECT LVL	-9dB
ACADEMY FILTER	ON
SURR ROLLOFF	3.1kHz
OUTPUT LEVELS	CUSTOM

◀ MONO SURROUND	
OUTPUT LEVELS	CUSTOM

◀ MONO	
SUB LEVEL	+0dB
OUTPUT LEVELS	CUSTOM

◀ NIGHTCLUB	
CENTER DEPTH	11
SPEECH DETECT	ON
SIZE	5m
LIVENESS	196ms
PRE-DELAY	5ms
ROLLOFF	9.0kHz
EFFECT LVL	+3dB
OUTPUT LEVELS	CUSTOM

◀ CONCERT HALL	
CENTER DEPTH	12
SPEECH DETECT	ON
SIZE	20m
LIVENESS	1.72s
PRE-DELAY	OFF
ROLLOFF	2.4kHz
EFFECT LVL	-2dB
OUTPUT LEVELS	CUSTOM

◀ CHURCH	
CENTER DEPTH	5
SPEECH DETECT	ON
SIZE	20m
MID RT	1.56s
BASS RT	1.87s
PRE-DELAY	24ms
ROLLOFF	2.4kHz
EFFECT LVL	-3dB
OUTPUT LEVELS	CUSTOM

CATHEDRAL

CENTER DEPTH	12
SPEECH DETECT	ON
SIZE	30m
MID RT	3.72s
BASS RT	4.47s
PRE-DELAY	23ms
ROLLOFF	3.1kHz
EFFECT LVL	-8dB
OUTPUT LEVELS	CUSTOM

PANORAMA

EFFECT LVL	+4dB
BASS CONTENT	STEREO
LOW FREQ WIDTH	+0
SURR ROLLOFF	3.1kHz
REAR DLY OFFSET	15ms
INPUT BALANCE	< >
CALIBRATION	
OUTPUT LEVELS	CUSTOM

5.1  FILM

VOCAL ENHANCE	+0.0dB
5 SPKR ENHANCE	ON
BASS ENHANCE	OFF
RE-EQUALIZER	ON
REAR DLY OFFSET	15ms
COMPRESSION	OFF
LFE MIX	+0.0dB
OUTPUT LEVELS	CUSTOM

5.1  TV

VOCAL ENHANCE	+0.0dB
5 SPKR ENHANCE	ON
BASS ENHANCE	OFF
RE-EQUALIZER	OFF
REAR DLY OFFSET	15ms
COMPRESSION	OFF
LFE MIX	+0.0dB
OUTPUT LEVELS	CUSTOM

5.1  MUSIC

VOCAL ENHANCE	+0.0dB
5 SPKR ENHANCE	ON
BASS ENHANCE	OFF
RE-EQUALIZER	OFF
REAR DLY OFFSET	15ms
COMPRESSION	OFF
LFE MIX	+0.0dB
OUTPUT LEVELS	CUSTOM

5.1  THX

RE-EQUALIZER	ON
SURROUND EX	AUTO
COMPRESSION	OFF
LFE MIX	+0.0dB
OUTPUT LEVELS	CUSTOM

5.1  THX MUSIC

COMPRESSION	OFF
LFE MIX	+0.0dB
OUTPUT LEVELS	CUSTOM

DIGITAL

EX DECODING	AUTO
COMPRESSION	OFF
LFE MIX	+0.0dB
OUTPUT LEVELS	CUSTOM

5.1 2-CHANNEL

CENTER MIX	+0dB
SURROUND MIX	+0dB
CNTR DLY SAMPLES	+0
MASTER LEVEL	+0dB
COMPRESSION	OFF
LFE MIX	+0.0dB
SUB LEVEL	+0dB
CUSTOM	

5.1 MONO LOGIC

EFFECT LVL	-9dB
ACADEMY FILTER	ON
SURR ROLLOFF	3.1kHz
OUTPUT LEVELS	CUSTOM

5.1 MONO SURR

OUTPUT LEVELS	CUSTOM
---------------	--------

5.1 MONO

SUB LVL	+0dB
CUSTOM	

  FILM



VOCAL ENHANCE	+0.0dB
5 SPKR ENHANCE	ON
BASS ENHANCE	OFF
RE-EQUALIZER	ON
REAR DLY OFFSET	15ms
LFE MIX	+0.0dB
 DECODING	AUTO
OUTPUT LEVELS	CUSTOM

  MUSIC

VOCAL ENHANCE	+0.0dB
5 SPKR ENHANCE	ON
BASS ENHANCE	OFF
REAR DLY OFFSET	15ms
LFE MIX	+0.0dB
 DECODING	AUTO
OUTPUT LEVELS	CUSTOM

  THX



RE-EQUALIZER	ON
LFE MIX	+0.0dB
 DECODING	AUTO
OUTPUT LEVELS	CUSTOM

  THX MUSIC

LFE MIX	+0.0dB
OUTPUT LEVELS	CUSTOM

LFE MIX	+0.0dB
 DECODING	AUTO
OUTPUT LEVELS	CUSTOM

  2-CHAN

CENTER MIX	+0dB
SURROUND MIX	+0dB
CNTR DLY SAMPLES	+0
MASTER LEVEL	+0dB
LFE MIX	+0.0dB
 DECODING	AUTO
SUB LEVEL	+0dB
CUSTOM	

5.1a BYPASS

OUTPUT LEVELS	CUSTOM
---------------	--------

2CH BYPASS

NO PARAMETERS	
---------------	--

Menu Tree (continued from page A-11)

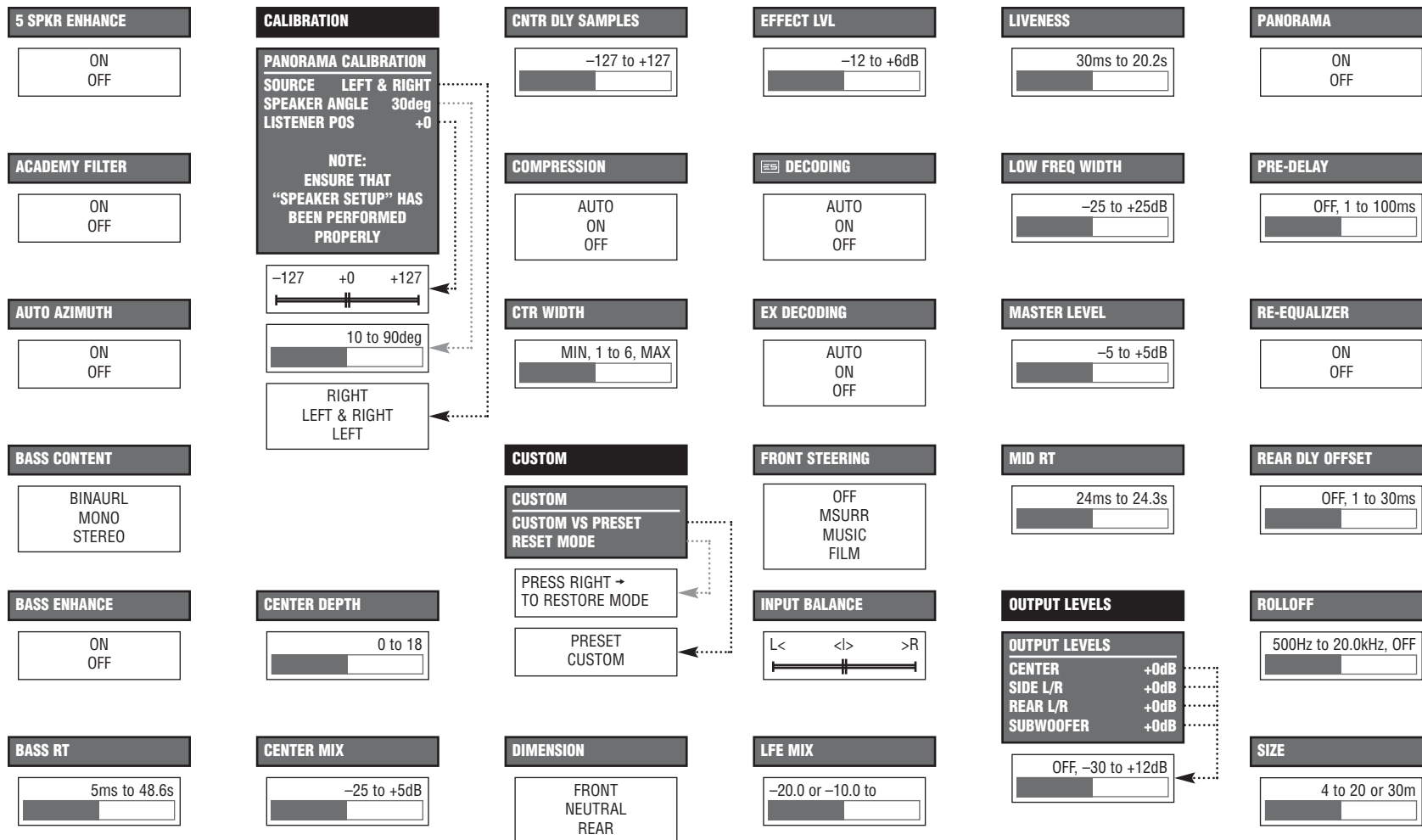

When the Shift 1 command bank is active, pressing the remote control Stat button opens the STATUS menu for the current input source. This menu contains parameters that provide information about the current input source and listening mode. STATUS menus are available for 2-channel, Dolby Digital, DTS(-ES), digital and analog input sources. Refer to page 2-14 for more information.

STATUS menu parameters provide information about the current input source and listening mode. These parameters cannot be adjusted. Refer to the STATUS Menu Parameter Descriptions section that begins on page 2-19 for more information.

SOUND STAGE

FRONT
NEUTRAL
REAR

SURROUND DLY

0 to 15ms

SPEECH DETECT

ON
OFF

SURROUND EX

AUTO
ON
OFF

SUB LEVEL

OFF, -30 to +12dB

SURROUND MIX

-5 to +5dB

SURR ROLLOFF

500Hz to 20.0kHz, OFF

VOCAL ENHANCE

+6.0dB
+3.0dB
+0.0dB

2CH STATUS

INPUT
MODE
INPUT TYPE
SAMPLE RATE

DOD STATUS PG1

INPUT
MODE
CHANNELS
BIT RATE
EX ENCODING

DOD STATUS PG2

SAMPLE RATE
2.0 ENCODING
DIALOG OFFSET
MIX ROOM
CENTER MIX LVL
SURR MIX LVL

DTS STATUS PG1

INPUT
MODE
CHANNELS
BIT RATE
ENCODING

DTS STATUS PG2

WORD LENGTH
SAMPLE RATE

5.1a BYPASS STATUS

INPUT
MODE
INPUT TYPE

Activating the MC-4 while pressing and holding the front panel or remote control Mute button opens the FACTORY SETTINGS menu shown below. Refer to page 6-4 for more information.

FACTORY SETTINGS

EXIT
RESTORE DEFAULTS



FACTORY SETTINGS

HAVE BEEN RESTORED
PRESS ANY KEY
TO RESTART

2CH BYPASS STATUS

INPUT
MODE
INPUT TYPE

DIGITAL STATUS

INPUT
MODE
INPUT TYPE
SAMPLE RATE

INSTALLATION WORKSHEET

INPUT SETUP	DVD1	DVD2	SAT	VCR	TV	CD	TUNER	AUX
NAME								
DIGITAL IN								
ANALOG IN								
ANLG IN LVL								
VIDEO IN								
COMPONENT IN								
2-CH								
 D								
								
<i>ADVANCED</i>								
INPUT SELECT								
2-CH ANLG BYP								
S-VIDEO 16:9								
S-VIDEO 4:3 OSD								
COMPONENT OSD								

SPEAKER SETUP	CUSTOM SETUP	THX SETUP	SPEAKER DISTANCES	LEVELS CALIBRATION
FRONT LEFT/RIGHT		THX 80Hz		
CENTER		THX 80Hz		
SIDE LEFT/RIGHT		THX 80Hz		
REAR LEFT/RIGHT				
SUBWOOFER		THX 80Hz		
THX ULTRA2 SUB				
BGC				
ASA				
UNITS				
CAL NOISE				
LIMITER				
LIMIT ADJ				

REAR PANEL CONFIG	SETTINGS		
<i>Circle One</i>	8 STEREO INPUTS	5 ST. & (1) 5.1 ANLG	2 ST. & (2) 5.1 ANLG

Installation Worksheet (continued from page A-15)

DISPLAY SETUP	SETTING
ON-SCREEN DISPLAY	
STATUS	
POSITION	
FORMAT	
BACKGROUND	
REMOTE STATE	
FRONT PANEL DISPLAY	
STATUS	
BRIGHTNESS	
A/V SYNC DELAY	
CUSTOM NAME	
EDIT CUSTOM NAME	

VOLUME CONTROL SETUP	SETTING
POWER ON	
MUTE LEVEL	

TRIGGER SETUP	SETTING
REMOTE ONLY	
<i>If the REMOTE ONLY parameter is set to OFF, circle the inputs and listening modes selected for program operation.</i>	
DVD1	PANORAMA
DVD2	2-CH SURROUND
SAT	2-CHANNEL
VCR	MONO LOGIC
TV	MONO SURROUND
CD	MONO
TUNER	5.1 L7 FILM
PHONO	5.1 L7 TV
L7 FILM	5.1 L7 MUSIC
L7 TV	THX SurEX
L7 MUSIC	THX MUSIC
L7 MUSIC SURR	DOLBY DIGITAL EX
DOLBY PLII + THX	5.1 2-CHANNEL
DOLBY PLII MOVIE	5.1 MONO LOGIC
DOLBY PLII MUSIC	5.1 MONO SURR
DOLBY PRO LOGIC	5.1 MONO
DOLBY PL + THX	dts(-ES) L7 FILM
dts NEO:6 CIN	dts(-ES) L7 MUSIC
dts NEO:6 + THX	dts(-ES) THX
dts NEO:6 MUSIC	dts THX MUSIC
NIGHTCLUB	dts(-ES)
CONCERT HALL	dts(-ES) 2-CHAN
CHURCH	5.1a BYPASS
CATHEDRAL	2CH BYPASS

LOCK OPTIONS	SETTING
SETUP	
AUDIO CNTRL	
MODES	

AUDIO CONTROLS	SETTING
BASS	
TREBLE	
TILT EQ	
LOUDNESS	
BALANCE	
FADER	

Index

NUMBERS

2 CH button, 2-13, 3-20
2 ST. & (2) 5.1 ANLG setting, 3-44
2.0 ENCODING parameter, 2-18
2-CH ANALOG BYP parameter, 2-13, 3-20
2-CH parameter, 3-14
2-CH SURROUND listening mode, 2-13, 5-14
2-CHANNEL listening mode, 5-14
2CH BYPASS listening mode, 5-28
2CH BYPASS STATUS menu, 2-17
2CH STATUS menu, 2-15
5 SPKR ENHANCE parameter, 5-29
5 ST. & (1) 5.1 ANLG setting, 3-43 to 3-44
5.1 2-CHANNEL, 5-21
5.1 L7 FILM listening mode, 5-16
5.1 L7 MUSIC listening mode, 5-17
5.1 L7 TV listening mode, 5-16
5.1 MONO listening mode, 5-22
5.1 MONO LOGIC listening mode, 2-13, 5-21
5.1 MONO SURR listening mode, 5-22
5.1 THX listening mode, 2-14, 5-17 to 5-18
5.1 THX SurEX listening mode, 2-14, 5-17 to 5-18
5.1 THX Ultra2 listening mode, 2-14, 5-17 to 5-18
5.1-channel analog audio input connectors, 2-5, 3-43 to 3-44
5.1a BYPASS listening mode, 5-28

NUMBERS *(continued)*

5.1a BYPASS STATUS menu, 2-17
7/5 button, 2-13
8 STEREO INPUTS setting, 3-43

A

A/V SYNC DELAY parameter, 3-45
about the MC-4, 1-2 to 1-3
AC input connector, 2-4
ACADEMY FILTER parameter, 5-29
activating listening modes, 1-4, 2-13, 3-13 to 3-16, 5-2 to 5-3
ADVANCED menu, 3-17 to 3-23 (*ills.*)
advanced settings, input, 3-17 to 3-23
advanced speaker array (*see* ASA parameter)
analog audio input connectors (stereo), 2-5, 3-43 to 3-44
analog audio output connectors, 2-5, 3-44
ANALOG IN parameter, 3-8, 3-19
ANLG IN LVL menu, 3-9 to 3-11 (*ills.*)
arrow buttons, ii, 2-6 to 2-9, 2-11
ASA parameter, 3-32
assigning input connectors, 3-6 to 3-12
AUDIO CNTRL parameter, 3-54
AUDIO CONTROLS menu, 4-1 to 4-6 (*ills.*)
audio output connectors, 2-5, 3-44

A *(continued)*

AUTO AZIMUTH parameter, 5-29
AUTO GAIN parameter, 3-10
AUTO parameter, 3-9
AUX button, 2-3, 2-12

B

BACKGROUND parameter, 2-10, 3-23, 3-49
backlight, remote control, 2-11
BALANCE parameter, 2-10, 2-12, 4-6
BASS CONTENT parameter, 5-29
BASS ENHANCE parameter, 5-29
BASS parameter, 2-12, 4-2 to 4-3
BASS PEAK LIMITER menu, 3-41 to 3-42 (*ills.*)
BASS RT parameter, 5-30
battery installation, remote control, 1-5 (*ill.*), 2-6
BGC parameter, 3-31
BIT RATE parameter, 2-18
BLUE button, 2-10, 4-2, 4-4
boundary gain compensation (*see* BGC parameter)
BRIGHTNESS parameter, 3-50

C

CAL NOISE parameter, 3-41
 calibrating output levels, 3-37 to 3-42
 CALIBRATION menu, PANORAMA listening mode, 5-12 to 5-14 (*ills.*), 5-30
 CATHEDRAL listening mode, 2-13, 5-11
 CAUTION, ii
 CD button, 2-3, 2-12
 CENTER DEPTH parameter, 5-30
 CENTER MIX LVL parameter, 2-18
 CENTER MIX parameter, 5-30
 Center output connector, 2-5, 3-44
 CENTER parameters, 3-27, 3-36, 3-40, 5-30, 5-33
 changing input names, 3-4 to 3-5
 CHANNELS parameter, 2-18
 CHURCH listening mode, 2-13, 5-11
 CNTR DLY SAMPLES parameter, 5-30
 command bank activation, remote control, 2-9
 command bank indicator, remote control, 2-9
 command matrix, remote control, 2-9 to 2-14
 COMPONENT IN parameter, 3-12
 COMPONENT OSD parameter, 2-14, 3-23
 component video connectors, 2-5
 composite video connectors, 2-5
 COMPRESSION parameter, 5-30
 CONCERT HALL listening mode, 2-13, 5-10
 crossover points, determining, 3-24 to 3-25 (*ill.*)
 CTR WIDTH parameter, 5-30
 CUSTOM menu, 5-30
 CUSTOM NAME parameter, 3-46
 CUSTOM SETUP menu, 3-24 to 3-32 (*ills.*)
 custom speaker setups, 3-24 to 3-32
 CUSTOM VS. PRESET option, 5-31

D

Declaration of Conformity, A-4
 default command bank, 2-9, 2-10 to 2-14
 determining crossover points, 3-24 to 3-25 (*ill.*)
 DIALOG OFFSET parameter, 2-18
 digital audio input connectors, 2-4 to 2-5
 DIGITAL STATUS menu, 2-17
 DIGITAL IN parameter, 3-7, 3-19
 DIMENSION parameter, 5-31
 DISPLAY SETUP menu, 3-2, 3-45 to 3-50 (*ills.*)
 documentation conventions, ii
 DOLBY button, 2-13, 2-14, 5-3
 DOLBY D parameter, 3-15
 DOLBY DIGITAL EX listening mode, 2-14, 5-19 to 5-20
 DOLBY DIGITAL listening mode, 2-14, 5-19 to 5-20
 DOLBY PL + THX listening mode, 5-7
 DOLBY PLII + THX listening mode, 5-6
 DOLBY PLII MOVIE listening mode, 2-13, 5-6
 DOLBY PLII MUSIC listening mode, 5-7
 DOLBY PRO LOGIC listening mode, 5-8
 DOLBY STATUS menu, 2-16
 DTS button, 2-13, 2-14, 5-3
 DTS NEO:6 + THX listening mode, 5-8
 DTS NEO:6 CIN listening mode, 2-13, 5-9
 DTS NEO:6 MUSIC listening mode, 5-9
 DTS THX MUSIC listening mode, 5-26
 DTS THX Ultra2 listening mode, 5-25 to 5-26
 DTS(-ES) 2-CHAN listening mode, 5-27
 DTS(-ES) L7 FILM listening mode, 5-24
 DTS(-ES) L7 MUSIC listening mode, 5-24
 DTS(-ES) listening mode, 5-27

D (continued)

DTS(-ES) parameter, 3-16
 DTS(-ES) STATUS menu, 2-16
 DTS(-ES) THX listening mode, 5-25 to 5-26
 DTS-ES decoding, 5-23
 DVD1 button, 2-3, 2-12
 DVD2 button, 2-3, 2-12

E

EDIT CUSTOM NAME menu, 3-46
 EDIT INPUT NAME menu, 3-4 to 3-5
 EFFECT LVL parameter, 5-31
 ES DECODING parameter, 2-14, 2-18, 5-23, 5-25 to 5-26, 5-31 to 5-32
 EX DECODING parameter, 2-14, 2-18, 5-20, 5-32
 EXTERNAL NOISE TEST, 3-39

F

factory-default settings, restoring, 6-4
 FADER parameter, 2-10, 2-12, 4-6
 FORMAT parameter, 3-48
 FP button, 2-10, 4-6
 Front L/R output connector, 2-5
 FRONT L/R parameters, 3-26, 3-36, 3-40, 3-44
 FRONT PANEL DISPLAY menu, 3-50 (*ill.*)
 front panel display, 2-2
 front panel overview, 2-2 to 2-3 (*ill.*)
 FRONT STEERING parameter, 5-32

H

highlights, MC-4, 1-3
 horizontal bar graphs, 2-8

I

INPUT BALANCE parameter, 5-32

input connectors

- 5.1-channel analog audio, 2-5, 3-43 to 3-44
- analog audio (stereo), 2-5, 3-43 to 3-44
- assigning, 3-6 to 3-12
- component video, 2-5
- composite video, 2-5
- digital audio, 2-4 to 2-5
- IR, 2-5
- RCA, 2-5
- S/PDIF, 2-4 to 2-5
- S-video, 2-5
- video, 2-5

input names, changing, 3-4 to 3-5

INPUT parameter, 2-19

INPUT SELECT parameter, 2-13, 3-18 to 3-19

input selection button LEDs, 2-3

input selection buttons, 2-3, 2-12

INPUT SETUP menu, 3-2, 3-3 to 3-23 (*ills.*)

INPUT TYPE parameter, 2-19

inputs, advanced settings, 3-17 to 3-23

installation considerations, 1-4

installation worksheet, A-14 to A-16

INTERNAL NOISE TEST, 3-37 to 3-38

international safety instructions, v–ix

IR IN connector, 2-5

IR receiver LEDs, 2-3

IR receiver, 1-4, 2-3 (*ill.*), 2-6

L

L7 button, 2-13, 5-3

L7 FILM listening mode, 5-4

L7 MUSIC listening mode, 2-13, 5-5

L7 MUSIC SURR listening mode, 2-13, 5-5

L7 TV listening mode, 5-4

LEDs

- input selection button, 2-3
- IR receiver, 2-3
- standby button, 2-2
- Mute button, 2-3

level meters, 2-19, 3-11

LFE MIX parameter, 5-33

Light button, 2-11

LIMIT ADJ parameter, 3-42

Limited Warranty, inside back cover

LIMITER parameter, 3-42

LISTENER POS parameter, 5-14, 5-33

listening mode menu parameters, 5-29 to 5-37

listening mode selection buttons, 2-13

listening modes, activating, 1-4, 2-13, 3-13 to 3-16, 5-2 to 5-3

listening modes, preferred, 3-13 to 3-16

LIVENESS parameter, 5-33

LOCK OPTIONS menu, 3-3, 3-54 (*ill.*)

Logic 7 (*see* L7)

LOUDNESS parameter, 2-12, 4-4 to 4-5

LOW FREQ WIDTH parameter, 5-33

M

MAIN MENU, 2-7 (*ill.*)

maintenance, 6-3

MANUAL parameter, 3-10

MASTER LEVEL parameter, 5-33

MC-4

- about the, 1-2 to 1-3
- highlights, 1-3
- installation considerations, 1-4
- maintenance, 6-3
- product registration, 1-4
- specifications, A-2 to A-3
- unpacking, x

menu arrow buttons, ii, 2-6 to 2-9, 2-11

menu item selection, 2-7 to 2-9, 2-11

menu navigation, ii, 2-6 to 2-9, 2-11

menu trees, A-4 to A-13

MID RT parameter, 5-33

MIX ROOM parameter, 2-19

Mode ▲/▼ buttons, 2-3, 2-11, 5-2 to 5-3

MODE ADJUST menu, 2-3, 5-1 to 5-37 (*ills.*)

mode family selection buttons, 2-13, 5-2 to 5-3

MODE parameter, 2-19

MODES parameter, 3-54

MONO listening mode, 5-15

MONO LOGIC listening mode, 2-13, 5-15

MONO SURROUND listening mode, 5-15

Music button, 2-13, 5-3

Mute button LED, 2-3

Mute button, 2-3, 2-11

MUTE LEVEL parameter, 2-3, 3-51

MUTE ON message, 2-3

O

Off button, 2-10
 On button, 2-4, 2-10
 ON-SCREEN DISPLAY menu, 3-47 to 3-49 (*ills.*)
 operation considerations, remote control, 2-6
 options, menu, 2-8
 OSD button, 2-10
 output connectors
 audio, 2-5, 3-44
 Center, 2-5, 3-44
 component video, 2-5
 composite video, 2-5
 Front L/R, 2-5, 3-44
 RCA, 2-5
 Rear L/R, 2-5, 3-44
 S-video, 2-5
 Side L/R, 2-5, 3-44
 Subwoofer, 2-5, 3-44
 Trigger, 2-6, 2-10, 3-52 to 3-53
 OUTPUT LEVELS menu, 5-33
 output levels, calibrating, 3-37 to 3-42

P

PANORAMA CALIBRATION menu, 5-12 to 5-14 (*ills.*), 5-30
 PANORAMA listening mode, 2-13, 5-12 to 5-14
 PANORAMA parameter, 5-34
 parameter drop-down menus, 2-8
 parameters, adjusting, 2-8
 parameters, listening mode menu, 5-29 to 5-37
 parameters, preferred listening mode selection, 3-13 to 3-16, 5-2 to 5-3

P (*continued*)

parameters, STATUS menu, 2-18 to 2-19
 POSITION parameter, 2-14, 3-48
 POWER ON parameter, 3-51
 power switch, 2-2, 2-4
 PRE-DELAY parameter, 5-34
 preferred listening mode selection parameters, 3-13 to 3-16, 5-2 to 5-3
 product registration, 1-4
 program operation (trigger), 3-52 to 3-53
 PROGRAM setting, 3-53

R

RCA connectors, 2-5
 REAR DLY OFFSET parameter, 5-34
 Rear L/R output connector, 2-5, 3-44
 REAR L/R parameters, 3-29, 3-34, 3-36, 3-40, 5-33, 5-34
 REAR PANEL CONFIG menu, 3-2, 3-43 to 3-44 (*ills.*)
 rear panel overview, 2-4 to 2-6 (*ill.*)
 RE-EQUALIZER parameter, 5-34
 remote control
 backlight, 2-11
 battery installation, 1-5 (*ill.*), 2-6
 command bank activation, 2-9
 command bank indicator, 2-9
 command matrix, 2-9 to 2-14
 operation considerations, 2-6
 overview, 2-6 to 2-14 (*ills.*)
 REMOTE ONLY setting, 3-52
 remote operation (trigger), 2-10, 3-52 to 3-53
 REMOTE STATE parameter, 2-9, 3-49

R (*continued*)

RESET MODE option, 5-34 to 5-35
 RESTORE DEFAULT NAME option, 3-5
 restoring factory-default settings, 6-4
 ROLLOFF parameter, 5-35
 RS-232 connectors, 2-6

S

S/PDIF input connectors, 2-4 to 2-5
 S-VIDEO 16:9 parameter, 3-21
 S-video connectors, 2-5
 S-VIDEO OSD parameter, 3-22
 S1 button, 2-9, 2-10, 2-13, 2-14
 S2 button, 2-9, 2-10
 safety instructions, inside front cover, ii, v to ix, x
 SAMPLE RATE parameter, 2-19
 Sat button, 2-3, 2-12
 selection, menu item, 2-7 to 2-9, 2-11
 SETUP menu, 3-1 to 3-54
 SETUP parameter, 3-54
 Shift 1 command bank, 2-9, 2-10 to 2-14
 Shift 2 command bank, 2-9, 2-10 to 2-14
 Side L/R output connector, 2-5, 3-44
 SIDE L/R parameters, 3-28, 3-36, 3-40, 5-33, 5-35
 SIZE parameter, 5-35
 SOUND STAGE parameter, 5-35
 SOURCE parameter, 5-13, 5-35
 SPEAKER ANGLE parameter, 5-14, 5-35
 SPEAKER DISTANCES menu, 3-35 to 3-36 (*ills.*)
 speaker distances, measuring, 3-35 to 3-36
 SPEAKER LEVEL ADJUST menu, 3-37 to 3-40 (*ills.*)
 SPEAKER SETUP menu, 3-2, 3-24 to 3-42 (*ills.*)

S *(continued)*

specifications, A-2 to A-3
 SPEECH DETECT parameter, 5-36
 standby button LED, 2-2
 standby button, 2-2, 2-4
 standby mode, 2-2, 2-4, 2-10
 Stat button, 2-10, 2-14, 2-15
 STATUS menu parameters, 2-18 to 2-19
 STATUS menu, 2-10, 2-14 to 2-19
 STATUS parameter, FRONT PANEL DISPLAY menu, 2-3, 2-10, 3-50
 STATUS parameter, ON-SCREEN DISPLAY menu, 2-10, 2-14, 3-47
 status, two-line, 2-10, 2-14
 SUB LEVEL parameter, 5-36
 Subwoofer output connector, 2-5, 2-11, 3-44
 SUBWOOFER parameters, 3-30, 3-36, 3-40, 5-33, 5-36
 SURR MIX LVL parameter, 2-19
 SURR ROLLOFF parameter, 5-36
 SURROUND DLY parameter, 5-36
 SURROUND EX parameter, 5-18, 5-36 to 5-37
 SURROUND MIX parameter, 5-37

T

table of contents, iii to iv
 THX button, 2-13, 2-14, 5-3
 THX MUSIC listening mode, 2-13, 5-19
 THX reference levels, 2-3
 THX SETUP menu, 3-31, 3-32, 3-33 to 3-34 (*ills.*)
 THX speaker setups, 3-31, 3-32, 3-33 to 3-34 (*ills.*)
 THX ULTRA2 SUB parameter, 3-31
 TILT EQ parameter, 2-10, 2-12, 4-4 to 4-5

T *(continued)*

TREBLE parameter, 2-10, 2-12, 4-2 to 4-3
 Trigger output connectors, 2-6, 2-10, 3-52 to 3-53
 TRIGGER SETUP menu, 3-2, 3-52 to 3-53
 troubleshooting, 6-2 to 6-3
 Tuner button, 2-3, 2-12
 TV button (input selection), 2-3, 2-12
 TV button (listening mode selection), 2-13, 5-3
 two-line status, 2-10, 2-14

U

UNITS parameter, 3-36
 unpacking, x
 USE LAST setting, 3-14 to 3-16

V

VCR button, 2-3, 2-12
 VIDEO IN parameter, 3-11
 VOCAL ENHANCE parameter, 5-37
 Vol ▲/▼ buttons, 2-11
 VOLUME CONTROL SETUP menu, 3-2, 3-51 (*ill.*)
 volume knob, 2-3

W

WARNING, ii
 warranty, inside back cover
 WORD LENGTH parameter, 2-19

LIMITED WARRANTY

Harman Specialty Group offers the following warranty on this product:

What is the Duration of this Warranty?

This warranty will remain in effect for three (3) years from the original date of purchase.

Who is Covered?

This warranty may be enforced by the original purchaser and subsequent owners during the warranty period, provided the original dated sales receipt or other proof of warranty coverage is presented at time of service.

What is Covered?

This warranty covers all defects in material and workmanship on this product, except as specified below. The following are not covered:

1. Damage resulting from
 - A. Accident, misuse, abuse, or neglect.
 - B. Failure to follow instructions contained in the user guide.
 - C. Repair or attempted repair unauthorized by Harman Specialty Group.
 - D. Failure to perform recommended periodic maintenance.
 - E. Causes other than product defects, including lack of skill, competence, or experience on the part of the owner.

2. Damage occurring during any shipment of this product. Claims for shipping damages must be made with the carrier.
3. Damage to a unit that has been altered, or on which the serial number has been defaced, modified, or removed.

What Expenses will Harman Specialty Group Assume?

Harman Specialty Group will pay all labor and material expenses for covered items. Payment of shipping charges is discussed in the next section of the warranty.

How is Service Obtained?

When this product needs service, write, telephone, or fax Harman Specialty Group to request information about where the unit should be taken or sent. When making a written request, please include your name, complete address, and daytime telephone number; the product model and serial numbers; and a description of the problem. Do not return the unit to Harman Specialty Group without prior authorization.

When Shipping a Product for Service . . .

1. Pay any initial shipping charges, which are the responsibility of the owner. If necessary repairs are covered by this warranty, Harman Specialty Group will pay return shipping charges to any destination in the United States using the carrier of our choice.
2. Pack the unit securely. Package insurance is strongly recommended.

3. Include a copy of the original dated sales receipt. (A copy of the original dated sales receipt must be presented whenever warranty service is required.)
4. Do not include accessories such as power cords or user guides unless instructed to do so.

What are the Limitations of Implied Warranties?

Any implied warranties, including warranties of merchantability and fitness for a particular purpose, are limited in duration to the length of this warranty.

What Certain Damages are Excluded?

Harman Specialty Group's liability for a defective product is limited to repair or replacement of that product, at our option. Harman Specialty Group shall not be liable for damages based on inconvenience; loss of use of the product; loss of time; interrupted operation; commercial loss; or any other damages, whether incidental, consequential, or otherwise.

How do State Laws Relate to this Warranty?

Some states do not allow limitations on the duration of implied warranties and/or the exclusion or limitation of incidental or consequential damages. As such, the above limitations may not apply.

This warranty is not enforceable outside of North America. This warranty provides specific legal rights. Additional rights may be provided by some states.



PRODUCT REGISTRATION

Please register this product within 15 days of purchase. To do so, complete and return this card or register online at www.harmanspecialtygroup.com. This card serves no warranty purposes. Retain the sales receipt for proof of coverage.

<input type="radio"/> Mr.	<input type="radio"/> Mrs.	<input type="radio"/> Ms.	<input type="radio"/> Miss
<input type="radio"/> Single	<input type="radio"/> Married	<input type="radio"/> Divorced	<input type="radio"/> Widowed
First Name		Last Name	
Company		Title	
Mailing Address			
City		State	Zip
Telephone Number		Fax Number	
Email Address			
Product Model		Purchase Date	
Version		Serial Number	
Where did you purchase this product?			
Age	Education	Household Income	
<input type="radio"/> Under 18	<input type="radio"/> High School	<input type="radio"/> Under \$20,000	
<input type="radio"/> 18-24	<input type="radio"/> College	<input type="radio"/> \$20,000 to \$34,999	
<input type="radio"/> 25-34	<input type="radio"/> Graduate School	<input type="radio"/> \$35,000 to \$49,000	
<input type="radio"/> 35-49	<input type="radio"/> Certificate:	<input type="radio"/> \$50,000 to \$74,999	
<input type="radio"/> 50-64		<input type="radio"/> \$75,000 to \$99,000	
<input type="radio"/> 65+		<input type="radio"/> \$100,000+	
How did you learn about this product? Choose one:			
<input type="radio"/> Friend	<input type="radio"/> Store salesperson	<input type="radio"/> Advertisement	
<input type="radio"/> Colleague	<input type="radio"/> Store display	<input type="radio"/> Magazine Article	
<input type="radio"/> Teacher	<input type="radio"/> Received as a gift	<input type="radio"/> Own other Lexicon products	
Which of the following were most important in the selection of this product?			
<input type="radio"/> Sound	<input type="radio"/> Quality	<input type="radio"/> Value for price	<input type="radio"/> Durability
<input type="radio"/> Features	<input type="radio"/> Brandname	<input type="radio"/> Other:	
What are your three favorite magazines?			
1.	2.	3.	
What are your three favorite websites?			
1.	2.	3.	
What features would you like to see added to this product in the future?			



Harman Specialty Group
3 Oak Park
Bedford, MA 01730-1413
USA

Telephone: 781-280-0300
Fax: 781-280-0490
www.lexicon.com

Customer Support
Telephone: 781-280-0300
Sales Fax: 781-280-0495
Service Fax: 781-280-0499



BUSINESS REPLY MAIL
FIRST-CLASS MAIL PERMIT NO. 67 BEDFORD MA

POSTAGE WILL BE PAID BY ADDRESSEE

PRODUCT REGISTRATION
HARMAN SPECIALTY GROUP
3 OAK PARK
BEDFORD MA 01730-9863



NO POSTAGE
NECESSARY
IF MAILED
IN THE
UNITED STATES

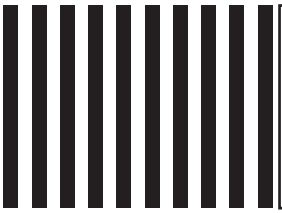

3 Oak Park
Bedford, MA 01730-1413 USA
Tel 781-280-0300
Fax 781-280-0490
www.lexicon.com

Customer Support
Telephone: 781-280-0300
Sales Fax: 781-280-0495
Service Fax: 781-280-0499

Product Shipments
16 Progress Road
Billerica, MA 01821-5730 USA

harman specialty group

Part No. 070-15838 | Rev 0 | 10/04