

# Z-SERIES

Z142 Remote Controlled Integrated Amplifier

Owner's manual

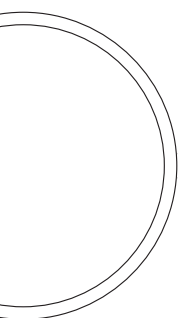

 142

# CONTENTS

• <b>Introduction</b>	2
• <b>Installation and Safety</b>	2
• <b>Accessories</b>	2
• <b>Setting up your Amplifier</b>	3
Rear panel connections	
• <b>Operating your Amplifier</b>	5
Front panel controls	
• <b>Loudspeaker Output Protection and Muting</b>	6
• <b>Remote Control Handset Operation</b>	6
• <b>System Operation with Smart My-Link</b>	7
• <b>Installing and Replacing Batteries</b>	7
• <b>Trouble-shooting guide</b>	7
• <b>Specifications</b>	7

## INTRODUCTION

The Myryad Z142 Integrated Amplifier has been designed to offer a combination of high quality sound reproduction and elegant styling. The Z142 can accept up to six line-level input sources, including two tape recorders. Outputs are provided for one pair of loudspeakers, for headphones and for an auxiliary power amplifier. All functions – input selection, volume and standby – can be operated using the infra-red remote control handset supplied.

The Z142 offers a range of expansion possibilities:

- The Smart My-Link® input can be connected to a Myryad CD player and Tuner – for example - which will automatically be switched on or off when the Z142 is switched on or off.
- The Smart My-Link® input/output can be coupled to other Myryad products that can then be remote-controlled via the Z142's infra-red receiver - or vice-versa.
- When linked via the Smart My-Link® to other Z-Series products or other compatible Myryad products, a number of extra features become available which make the system as a whole easier and quicker to operate.

## INSTALLATION AND SAFETY

The Z142 generates a modest amount of heat and requires ventilation. Do not place it on a rug or other soft surface into which it could sink, obstructing the air inlets in its underside. Do not allow any obstruction to the ventilation slots in the top cover. If a number of Z-Series units are stacked on top of one another, the Z142 should be placed on top. The Z142 should not be installed in a built-in situation such as a bookcase or rack unless proper ventilation is provided.

**CAUTION: THIS APPARATUS MUST NOT BE EXPOSED TO DRIPPING OR SPLASHING. OBJECTS FILLED WITH LIQUIDS SUCH AS VASES MUST NOT BE PLACED ON THE APPARATUS.**

**THE REAR PANEL POWER SWITCH DISCONNECTS MAINS LIVE ONLY. THE POWER CORD MUST BE DISCONNECTED FROM THE REAR OF THE APPARATUS, OR THE WALL SOCKET, TO PROVIDE TOTAL ISOLATION. ONE OR OTHER OF THESE CONNECTIONS MUST BE READILY ACCESSIBLE WHEN THE APPARATUS IS IN USE.**

Do not remove the cover, or attempt to modify or repair any item yourself. Refer all servicing to a qualified technician.

## ACCESSORIES

Your Z142 is supplied with the following accessories.

- Separate mains power cord to suit country of sale.
- My-Link interconnect (0.5m RCA-RCA).
- MSR2 remote control handset.
- MSR2 System Remote Control Owner's Manual
- Two AAA batteries for handset (not in some countries).

# SETTING UP YOUR AMPLIFIER

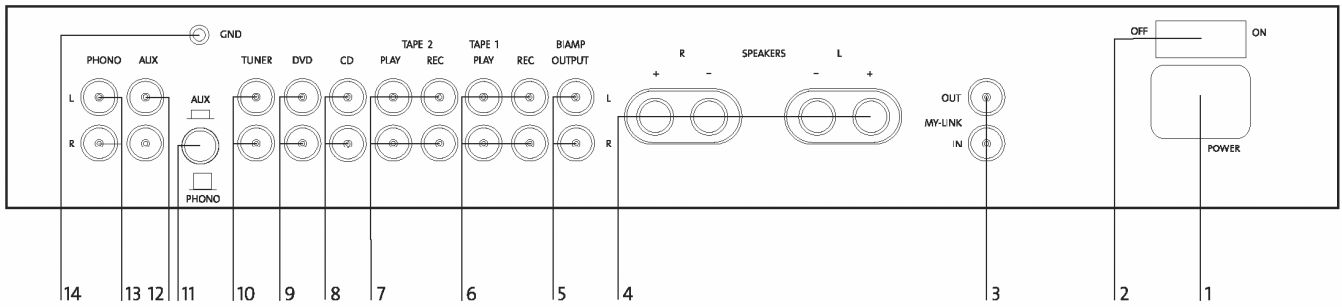

## REAR PANEL CONNECTIONS

### 1 Power inlet

Before making any connection, check that the mains voltage setting printed on the rear panel is the same as your local mains supply. Plug the female (socket) end of the power cord into the power inlet on the rear of the amplifier. Plug the male (plug) end of the cord into a "live" wall socket or a suitable heavy duty extension cable.

### 2 Power switch

Press one side of this rocker switch (the side nearer the edge of the rear panel) to switch the amplifier ON and the other side to switch it OFF. When the POWER switch is in the OFF position all power is disconnected from the amplifier and it cannot be powered up from the front panel or the remote control. When the POWER switch is in the ON position (and the power cord correctly inserted and plugged in to a live wall socket) the amplifier will power up in standby mode (see FRONT PANEL CONTROLS, STANDBY, page 5). It is recommended that the POWER switch is turned OFF if the amplifier is not going to be used for an extended period of time.

### 3 My-Link input/output

When the Z142 is used in a system with other Z-Series products (or Myryad MX-Series), all may be joined together via the My-Link. My-Link is a communications bus that allows all the linked components to operate together as a system and distributes the remote commands received by any one to each of the others.

The simplest function provided by the My-Link bus is that all linked units will switch into or out of standby mode when the amplifier's front panel or remote control standby key is pressed.

The My-Link bus allows any linked product to be remote-controlled via the tuner's infra-red receiver - or vice-versa.

The Z142 (or any other product on the My-Link bus) can be controlled from a remote room via a suitable interface to the My-Link bus.

Use a short RCA-to-RCA (phono-to-phono) interconnect cable to connect from the MYLINK OUT socket on the Z142 to the MY-LINK IN socket on the CD player and a second cable from the MY-LINK OUT socket on the CD player to the MY-LINK IN socket on the tuner - "daisy-chain" fashion. Further Myryad Z-Series or MX-Series products can be linked in the same way, running from the MY-LINK OUT socket on the tuner. Inexpensive interconnects may be used as the Smart My-Link bus carries only control signals, not audio, so these cables have no effect on sound quality.

When other Myryad products equipped with Smart My-Link® (e.g. Z-Series or MX-Series) are connected via the My-Link many more powerful system features are available (see page 7).

### 4 Loudspeaker outputs

The loudspeaker outputs are capable of driving all loudspeakers with rated impedances in the range 4Ω to 16Ω. The loudspeaker terminals are high-current binding-posts, coded red or black. The terminals on the left side of the amplifier (viewed from the front) and marked "L" should be wired to the left-hand loudspeaker. Those on the right, marked "R", should be wired to the right-hand loudspeaker.

For correct stereo imaging it is important that the two loudspeakers are wired "in phase". To ensure correct phasing wire the black (-) terminal on the amplifier to the black or "-" terminal on the loudspeaker. The red (+) terminal on the amplifier should be wired to the red or "+" terminal on the loudspeaker.

The loudspeakers should be positioned as recommended by the loudspeaker manufacturer. The two loudspeakers should always be placed at equal distances from the main listening position and usually spaced a similar distance apart. It is generally best to keep the loudspeakers away from room corners and many loudspeakers work best away from all walls.

### 5 Bi-amp output

Many loudspeakers today are made so that the bass and treble sections can be separated and fed from two sets of speaker cables. This is known as "bi-wiring" and can yield a significant improvement in sound quality. A further sound quality gain may be made by "bi-amplifying" the loudspeaker - using two separate power amplifiers to drive the bass and treble sections.

The Z142 makes provision for this with its "BI-AMP" output, which can be used to feed a separate Myryad Power Amplifier.

### 6 Tape 1 input/output

These connectors are suited to any type of tape or CD recorder, including high-quality "3-head" tape recorders which allow you to monitor the signal off the tape whilst it is being recorded. Connect a stereo cable from the TAPE 1 REC output sockets of the amplifier to the LINE IN or RECORD IN sockets on your tape deck. Connect a second stereo cable from the TAPE 1 PLAY input sockets of the amplifier to the LINE OUT or PLAY OUT sockets on your tape deck.

Any source selected for listening on the amplifier will automatically be fed to the TAPE 1 REC output sockets for recording. If the TAPE 2 input is selected then tape copies may be made from TAPE 2 to TAPE 1. It is NOT possible to copy from TAPE 1 to TAPE 2.

### **7 Tape 2 input/output**

These connectors are suited to any type of tape or CD recorder, but "off-tape" monitoring is not possible using TAPE 2. The wiring from TAPE 2 to your tape deck is identical to the TAPE 1 wiring described above.

Any source selected for listening, except TAPE 1, will automatically be fed to the TAPE 2 REC output sockets for recording. It is NOT possible to record from TAPE 1 to TAPE 2.

### **8 CD input**

Connect the audio output cables from a CD player to these sockets. If you do not have a CD player then any other line level source may be connected to this input.

**Note:** this input is for an audio signal, not for the digital output from your player.

### **9 DVD input**

Connect the audio signal output cables from a DVD player to these sockets. Use the outputs marked L and R or LF and RF (if the player has a built-in 5.1 channel decoder). Alternatively, any other line level source may be connected to this input.

**Note:** this input is for an audio signal, not for the digital output from your player.

### **10 Tuner input**

Connect the audio output cables from a radio tuner to these sockets. If you do not have a tuner then any other line level source may be connected to this input.

### **11 Phono/Aux switch**

This switch is used to select between the PHONO and AUX inputs described below. With the switch released (button protruding) the signals from a record player connected to the PHONO input will be heard when the PHONO input is selected. When the switch is pressed in, signals from the AUX input will be heard when PHONO is selected.

Sources can be left permanently connected to both the PHONO and AUX inputs and the PHONO/AUX switch used to select between them if desired.

### **12 AUX input**

The audio output from any line level source may be connected to this input.

### **13 Phono input**

Connect the audio output cables from a record player to these sockets. The input is designed for use with moving-magnet or "high-output" moving-coil phono cartridges. Consult your dealer if you are in any doubt what type of phono cartridge you have.

### **14 Ground terminal**

This terminal (marked GND) is provided for grounding a record player connected to the PHONO input. Some record players do not have a separate ground wire, in which case make no connection to this terminal.

# OPERATING YOUR AMPLIFIER

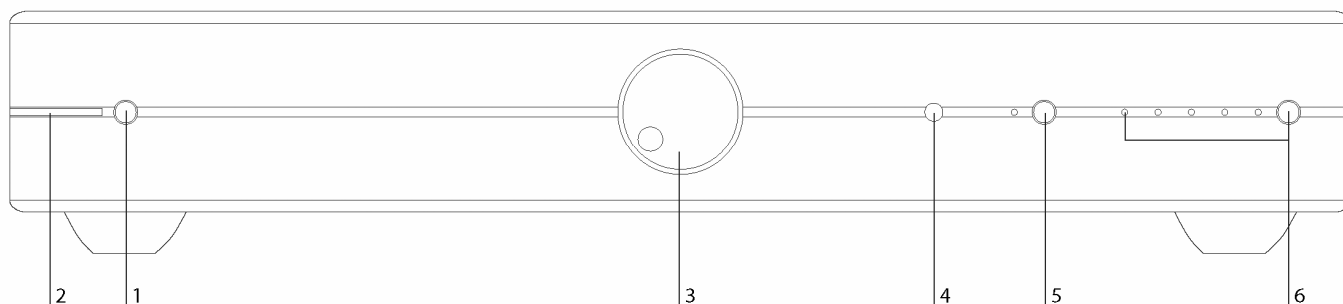

## FRONT PANEL CONTROLS

### 1 Standby

When amplifier is plugged into a live wall socket and the POWER switch is turned ON, it will power up in “standby” mode and the LED (Light Emitting Diode) by the STANDBY button will glow red. In this mode the internal circuitry is powered up, but disabled so that it consumes very little power and the loudspeaker outputs are muted by a relay.

When the STANDBY button is pressed the circuitry is activated and, after a few seconds delay, the audio outputs will be enabled. During this delay period while the internal circuitry is settling the STANDBY LED will flash blue. When the outputs are de-muted it will glow blue continuously. When the STANDBY button is pressed again the amplifier will be returned to standby mode, the STANDBY LED will glow red again and all other LEDs and displays will be extinguished.

When the Z142 is switched out of standby, the input used last is automatically selected and, after a few seconds settling delay, the loudspeaker outputs will be connected. When first switched out of standby after POWER ON, the CD input will be selected by default.

**CAUTION: WHEN IN STANDBY MODE THE INTERNAL CIRCUITRY IS STILL LIVE, SO ALL SAFETY PRECAUTIONS MUST BE FOLLOWED.**

### 2 Infra-red receiver

The infra-red (IR) remote control receiver is mounted behind the window next to the standby LED as indicated. It must therefore not be obscured when the unit is to be operated using the remote control handset. Where possible it is best to arrange that the IR window is in “line-of-sight” of the remote handset. When various components are connected via the My-Link bus, only one needs to receive the IR command signals in order to control any of the linked units.

### 3 Volume control

The volume control adjusts the sound level of the loudspeakers, bi-amp output and headphones. It does not affect the signals fed to the TAPE 1 and TAPE 2 REC sockets so it can safely be adjusted whilst making a recording.

When the MUTE mode is engaged using the remote control, the STANDBY LED will flash repeatedly to indicate this condition. Always press MUTE on the remote handset again to disengage MUTE before advancing the volume control setting.

### 4 Headphone socket

The headphones socket will accept a standard 3.5mm stereo jack plug or adapter. All types of headphones of any impedance may be used, with one exception: electrostatic headphones are usually supplied with an adapter unit which must be connected directly to the loudspeaker terminals. Insertion of a plug into the headphones socket automatically disconnects the loudspeakers, silencing them. In order to resume listening to loudspeakers you must unplug the headphones from this socket. The headphones output is not muted when switching in and out of STANDBY mode, so it is recommended that headphones are unplugged from the amplifier before switching to standby mode and plugged in again after switch-on.

### 5 Tape 1 (Monitor) and LED

When you press the TAPE 1 button you can hear the output signal from a tape deck connected to the TAPE 1 PLAY sockets on the rear panel. This is a “toggle” function switch: you press it once to engage and press again to disengage. The blue LED next to the TAPE 1 button illuminates to indicate that TAPE 1 is engaged.

Pressing the TAPE 1 button has no effect on any other input selected. The signal source selected by the SOURCE button will be fed to the TAPE 1 REC output sockets, irrespective of whether the TAPE 1 button is engaged or not. Thus, if you have a “three-head” tape deck that permits off-tape monitoring you can use the TAPE 1 button to switch back and forth between the source signal and the off-tape signal, to check its quality, whilst the recording is in progress.

**Note:** if the tape 1 button is engaged with no signal source connected to the tape 1 play sockets, or with no tape running, then you will hear only silence, regardless of the settings of any of the other controls.

### 6 Source select button and LEDs (Tape 2, CD, DVD, Tuner and Phono inputs)

The SOURCE select button is used to choose which signal source you want to listen to (apart from TAPE 1 – see above). The chosen signal source is indicated by one of the blue LEDs to the left of the source select button. When the button is pressed the next source is chosen, moving left to right (TAPE 2 → CD → DVD → TUNER → PHONO). If the button is pressed with PHONO selected the TAPE 2 input is selected next.

The selected source will be sent both to the loudspeakers and to the bi-amp output, as well as to the TAPE 1 REC and TAPE 2 REC output sockets for recording. The only exception is TAPE 2 which will not be fed to the TAPE 2 REC output sockets as this could cause dangerous oscillation. Recordings may be made from TAPE 2 to TAPE 1, but not from TAPE 1 to TAPE 2.

## LOUDSPEAKER OUTPUT PROTECTION AND MUTING

When the amplifier is in standby mode the loudspeaker output terminals are isolated from the amplifier by high quality relays. When the amplifier is first switched on from standby mode the loudspeaker outputs remain disconnected for a few seconds to allow the internal voltage levels to settle. The same process occurs when the amplifier is switched back into standby mode. This power-on mute does not disconnect the headphone socket, so it is recommended that headphones are unplugged from the amplifier before switching to standby mode and plugged in again after switch-on.

The same loudspeaker mute relay is used to protect both the amplifier and your loudspeakers against possible damage. If any one of a number of fault modes is detected (loudspeaker outputs short circuit, amplifier overheating, amplifier DC fault) the loudspeakers will be disconnected from the amplifier to protect both. In the case of a short circuit or DC fault the loudspeakers will be re-connected after a few seconds, but will be disconnected again if the fault persists. If overheating has caused the protection system to operate, then it will take some time for the heatsinks to cool sufficiently to allow the loudspeakers to be re-connected (probably between five and fifteen minutes depending upon the room temperature and ventilation). The amplifier will cool more quickly if it is switched to standby mode, or if the POWER is switched OFF.

## REMOTE CONTROL HANDSET OPERATION

The MSR2 handset supplied with the Z142 has been ergonomically designed to be easy and comfortable to use. It will also control Myryad's Integrated Amplifiers, Preamplifiers, Tuners and DVD Players. See the separate MSR2 System Remote Owner's manual for details of its use with these products.

The handset keys allocated to control of the Z142 are active in all handset modes and are as follows:

### Standby

This key operates in exactly the same way as the STANDBY button on the front panel.

### Vol ▲ and ▼

Pressing one of the VOLUME ▲ or ▼ keys will increase or decrease the volume setting - in exactly the same way as rotating the front panel volume control. If the amplifier is in mute mode (after pressing MUTE on the R/C handset) then pressing the VOLUME ▲ key will automatically disengage mute mode and re-connect the signal to the loudspeakers. This prevents an excessively high volume level from being set by mistake.

### Mute

Pressing the MUTE key on the handset will engage mute mode. The loudspeakers will be disconnected and the blue STANDBY LED will flash slowly. MUTE is a "toggle" function, so pressing the key again will disengage the mute mode.

### TP1, TP2, AUX, TV, CD, DVD, TUN

These keys allow direct access to input sources. The inputs selected are as follows:

TP1	selects	Tape 1
TP2	selects	Tape 2
AUX	selects	Phono/Aux
TV	selects	DVD (to maintain backward compatibility with earlier Myryad remotes)
CD	selects	CD
DVD	selects	DVD
TUN	selects	Tuner

When a new source is selected, the previous source is automatically cancelled, with the exception of TP1 (Tape 1) – see below.

### TP1 (Tape 1)

When you press the TP1 key you can hear the output signal from a recording device connected to the TAPE PLAY sockets on the rear panel. It operates in exactly the same way as the TAPE button on the front panel. Tape is a "toggle" function; you press the key once to engage and press again to disengage. The TAPE input also disengages if a new source is selected either from the remote or front panel.

# SYSTEM OPERATION WITH SMART MY-LINK®

When used as a linked system (which must include a Smart My-Link® equipped Integrated Amplifier like the Z142, or a Pre-amplifier) Myryad products equipped with Smart My-Link® have a number of extra features that make the system as a whole easier and quicker to use than a normal hi-fi. These include:

## **Start-on-Play (CD)**

Press play on the CD player (or the remote control) and both the CD player and amplifier will switch out of standby (if necessary) and play the CD. The amplifier will automatically select the CD source.

## **Start-on-Open (CD)**

Press open/close on the CD player (or the remote control) and both the CD player and amplifier will switch out of standby (if necessary) and the CD drawer will open. The amplifier will automatically select the CD source.

## **Intelligent Input Selection (Amplifier)**

Press a source select button on the remote control and the system will awaken only the amplifier and the selected source.

## **Mute/Pause Control (Amplifier/CD)**

When using the CD player, selecting mute from the remote control will mute the amplifier and pause the CD. When the amplifier mute is cancelled, the CD will continue playing.

## **Power-Saving Mode (Amplifier/Tuner/CD)**

The amplifier will switch the Tuner or CD Player into standby if either source remains unselected for more than ten minutes.

## **Automatic Switch-On (Tuner/CD)**

If the standby button on the Tuner or CD Player is pressed, the amplifier will also awaken and select the correct source.

# INSTALLING AND REPLACING HANDSET BATTERIES

The MSR2 Remote Handset uses two 1.5 V type AAA batteries. To fit new batteries first open the battery compartment in the rear of the handset and remove any existing batteries. Fit the new ones as directed by the symbols moulded inside the battery compartment, then replace the battery compartment cover. The batteries should always be removed if they are discharged (indicated by no remote control operation or by operation only at very short range), or if the remote control is not going to be used for an extended period.

# TROUBLE-SHOOTING GUIDE

Possible solutions to some of the most common problems.

## **No sound:**

- Power turned off or system in standby mode. Check that the blue STANDBY LED in the amplifier is illuminated and that the relevant source component is also active.
- An inoperative input has been selected (e.g. CD input with no CD playing).
- An input has been selected with no source connected.
- Protection relay has operated because of a short circuit loudspeaker wire or amplifier overheating. Carefully check all wiring after switching the amplifier POWER OFF to allow it to cool.
- UK version only: The fuse in the mains plug has failed. Check and replace if necessary.

## **Sound in one channel only:**

- Loudspeaker cable pulled loose. Check all connections, both at the loudspeakers and amplifier.
- Interconnect cable pulled loose or making poor contact. Check and, if necessary, un-plug and re-plug all relevant cables.

## **Loud buzz or hum:**

- Interconnect cable pulled partially out of its socket.
- Defective interconnect cable.

For further help please visit Myryad website at [www.myryad.co.uk](http://www.myryad.co.uk)

# SPECIFICATIONS

Continuous rated power output, 8Ω (<0.1% THD)	50W
Signal/noise ratio (A-weighted, ref 50W)	102dB
Input sensitivity (ref 50W)	Line inputs: 250mV Phono input: 2.5mV
Frequency response (20Hz – 20kHz)	±0.3dB
Dimensions (w x h x d)	436 x 78 x 316mm
Weight (net)	6.9kg
Supply voltage (set by internal wiring)	120 or 230V
Finish	Natural Silver fascia with Silver Grey casing or Satin Black fascia with Black Casing.



This symbol means do not dispose of as municipal waste.  
Re-use or recycle wherever possible. Electrical/Electronic  
Equipment may contain substances harmful to the  
environment. For environmentally sound methods of disposal,  
please contact your local government agency.

Revision: 1

---

  
MYRYAD

---

A horizontal line with several decorative circles of varying sizes and positions, including a small circle on the left, a medium circle in the middle, and a large circle on the right.