

Contents

IMPORTANT

In order to comply with current European safety regulations it is essential that the Naim loudspeaker connectors supplied with amplifiers and loudspeakers are used.

Do not under any circumstances allow anyone to modify your Naim equipment without first checking with the factory, your dealer, or your distributor. Unauthorised modifications will invalidate your guarantee.

For your own safety do not under any circumstances open Naim equipment without first disconnecting it from the mains.

The following label is attached to all mains powered equipment:



NOTE

This equipment has been tested and found to comply with the relevant EMC and Safety Standards, and, where applicable, also complies with the limits for a class B digital device, pursuant to Part 15 of the FCC Rules.

These limits are designed to provide reasonable protection against harmful interference in a residential installation. This equipment generates, uses and can radiate radio frequency and, if not installed and used in accordance with the instructions, may cause harmful interference to radio communications. However, there is no guarantee that interference will not occur in a particular installation. If this equipment does cause harmful interference to radio or television reception, which can be determined by turning off and on, the user is encouraged to try to correct the interference by one or more of the following measures:

- Reorient or relocate the receiving antenna.
- Increase the separation between the equipment and the receiver.
- Connect the equipment into an outlet on a circuit different from that to which the receiver is connected.
- Consult your Naim dealer or an experienced radio/TV technician for help.

Section

- 1 Equipment Installation**
- 2 Audio Connections**
 - 2.1 Interconnect Cables
 - 2.2 Loudspeaker Cables
- 3 Mains Power Connection**
 - 3.1 Mains Plug Wiring
 - 3.2 Non-rewirable Mains Plugs
 - 3.3 Mains Circuits and Cables
- 4 General Installation**
 - 4.1 Siting The Equipment
 - 4.2 Switching On
 - 4.3 Running In
 - 4.4 Radio Interference
 - 4.5 Non-standard Cables
 - 4.6 Lightning Precautions
 - 4.7 Liquid Precautions
 - 4.8 Equipment Fuses
 - 4.9 Problems?
 - 4.10 Repairs and Updates
- 5 Ariva Introduction and Installation**
- 6 Ariva Installation Diagrams**
- 7 Ariva Specification**

Declaration of conformity to appropriate standards

Manufacturer	Naim Audio Limited, Southampton Road, Salisbury, England, SP1 2LN
Products	Ariva
Safety	EN 60065
EMC	
Emissions Tested to:	EN 55013 - Sound and television broadcast receivers and associated equipment BS EN 61000-3-2: 2001 - Limits for harmonic current emissions (equipment input currents up to and including 16 A per phase)
Immunity Tested to:	EN55020 - Electromagnetic immunity of broadcast receivers and associated equipment
In accordance with:	CISPR 16-1 - Radio disturbance and immunity measuring apparatus CISPR 16-2 Methods of measurement of disturbances and immunity IEC 801-2 8kV (air gap) 4kV (contact) (performance criterion B) IEC 801-3 3V/m 20dB (performance criterion A) IEC 801-4 1kV (AC lines) 0.5kV (signal lines) (performance criterion B)

Introduction

Naim Audio products are conceived with performance as the top priority. Careful installation will help ensure that their full potential is achieved. This manual begins with general installation notes and statutory safety warnings for all Naim Audio products. Product specific information begins in Section 5.

1 Equipment Installation

Normally your Naim Audio equipment will have been installed by the dealer who sold it to you - even if you live outside their immediate vicinity. In any event however your dealer is responsible for making sure that the system sounds as it should. Information given here is not intended to reduce this responsibility in any way.

2 Audio Connections

It is important for both safety and performance that the standard cables supplied are not modified.

2.1 Interconnect Cables

If options are available with your equipment and installation, DIN interconnect sockets should be used in preference to RCA Phono sockets. One end of each Naim interconnect cable is marked with a band to establish its correct orientation. The band denotes the end that connects to the signal source.

Interconnect plugs and sockets should be kept clean and free from corrosion. The easiest way to clean them is to switch off the equipment, pull the plugs out of their sockets, and push them back in again. Contact cleaners and "enhancers" should not be used as the film they tend to deposit may degrade the sound.

2.2 Loudspeaker Cables

Loudspeaker cables are vitally important and your dealer should make them up to suit your installation. The cables should each be at least 3.5 metres long and of equal length. The recommended maximum is normally 20 metres although longer cables may be viable with some Naim amplifiers. Contact your dealer or Naim Audio for advice.

Many Naim amplifiers are designed only to work with Naim loudspeaker cable and using alternatives may degrade the performance or even damage the amplifier. Naim loudspeaker cable is directional and should be oriented so that the printed arrow points towards the speakers. The amplifier/loudspeaker connectors supplied are designed to make a robust electro-mechanical connection and to comply with European safety regulations. They should be used in preference to alternatives.

3 Mains Power Connection

Where fused plugs are used 13 amp fuses should be fitted. Fuses of a lower rating will fail after a period of use. Do not wire voltage dependent resistors or noise suppressors into mains plugs. They degrade the mains supply and the sound.

3.1 Mains Plug Wiring

In some territories a mains plug may need to be fitted to the supplied mains lead. As the colours of the wires in the mains lead may not correspond with the coloured markings identifying the terminals in the plug proceed as follows:

The wire which is coloured **GREEN-AND-YELLOW** must be connected to the terminal in the plug which is marked by the letter **E** or by the safety earth symbol or coloured **GREEN** or **GREEN and YELLOW**.

The wire which is coloured **BLUE** must be connected to the terminal in the plug which is marked with the letter **N** or coloured **BLACK**.

The wire which is coloured **BROWN** must be connected to the terminal in the plug which is marked with the letter **L** or coloured **RED**.

3.2 Non-rewirable Mains Plugs

If a non-rewirable plug is cut from a mains lead (for whatever purpose) the plug **MUST** be disposed of in a way to render it totally useless. Considerable shock hazard exists if the cut-off plug is inserted into a mains outlet.

3.3 Mains Circuits and Cables

A hi-fi system usually shares a mains circuit with other household equipment some of which can cause distortion of the mains waveform. This distortion can in turn lead to a mechanical hum from power amplifier and power supply transformers. Naim transformers are large in size with heavy gauge windings, making them relatively sensitive to such distortion, and it may be necessary to take account of transformer hum when siting your equipment.

Transformer hum is not transmitted through the speakers and has no effect on the performance of the system; however, a separate mains circuit may reduce it. Such a circuit (ideally with a 30 or 45 Amp rating) will also improve system performance. Advice on the installation of a separate mains circuit should be sought from a qualified electrician.

Do not substitute alternative mains leads and plugs to those supplied. They are selected to offer the best performance.

Introduction

4 General Installation

Naim equipment is designed to offer the finest sound quality possible avoiding compromise wherever practical. This can lead to circumstances that may be unfamiliar. The notes that follow contain advice specifically related to Naim equipment as well as more general warnings about the use of domestic audio products. Please read them carefully.

4.1 Siting The Equipment

In order to reduce the risk of hum audible from the loudspeakers, power supplies and power amplifiers should be located a reasonable distance away from other equipment. The maximum separation distance for connected equipment is that allowed by the standard interconnect lead.

Some Naim equipment is extremely heavy. Ensure that your equipment rack or table can easily support the weight and is stable.

4.2 Switching On

Source components and power supplies should be switched on before the power amplifiers. Always switch amplifiers off and wait a minute before connecting or disconnecting any leads. Always use the power switch on the product rather than a mains outlet switch.

A “thump” may be heard from the loudspeakers as power amplifiers are switched on. This is normal, will not cause any loudspeaker damage and does not point to any fault or problem. A mild “pop” may also be heard shortly after power amplifiers are switched off.

4.3 Running In

Naim equipment takes a considerable time to run in before it performs at its best. The duration varies, but under some conditions the sound may continue to improve for over a month. Better and more consistent performance will be achieved if the system is left switched on for long periods. It is worth remembering however that equipment left connected to the mains can be damaged by lightning.

4.4 Radio Interference

In some circumstances, depending on where you live and the earthing arrangements in your home, you may experience radio frequency interference. Controls on broadcasting in some territories allow very high levels of radio frequency radiation and both the choice and exact siting of equipment may be critical. Susceptibility to radio frequency interference is related to the wide internal bandwidth necessary for high sound quality. Systems incorporating moving coil phono preamplifiers and active crossovers are more likely to suffer. A radio frequency filter kit is available for some Naim equipment but sound quality will be progressively compromised as more elements of the kit are fitted. In situations of extreme radio interference Naim equipment may be unsuitable.

4.5 Non-standard Cables

Use of non-standard speaker cables or interconnects may invalidate your guarantee.

4.6 Lightning Precautions

Your Naim hi-fi system can be damaged by lightning. Power amplifiers are particularly at risk and should be turned off and disconnected from the mains when there is risk of lightning strike. For complete protection all mains plugs and any aerial cables should be disconnected when not in use.

4.7 Liquid Precautions

Equipment must not be exposed to dripping or splashing and no objects filled with liquid, such as vases, should be placed on the equipment.

4.8 Equipment Fuses

Mains powered Naim Audio equipment is fitted with a mains input fuse on the rear panel adjacent to the mains input socket. Replace it if necessary only with the spare fuse supplied or with identical fuses. Repeated failure of this fuse points to an equipment or system fault that should be investigated by your dealer or at the factory by Naim itself.

4.9 Problems?

Consumer protection varies from country to country. In most territories a dealer must be prepared to take back any equipment he has sold if it cannot be made to work satisfactorily. A problem may be due to a fault in the system or its installation so it is essential to make full use of your dealer's diagnostic skills. Please contact your local distributor, or Naim Audio directly, if any difficulties cannot be resolved.

Some Naim equipment is made in special versions for different territories and this makes it impracticable to arrange international guarantees. Please establish the local guarantee arrangements with your dealer. Contact Naim Audio directly for help and advice if necessary.

4.10 Repairs and Updates

It is essential that repairs and updates are only carried out by an authorised Naim dealer or at the factory by Naim itself. Many components are custom made, tested or matched and appropriate replacements are often unobtainable from other sources.

Direct contact to Naim for service or update information should be made initially through the Service Department:

Tel: +44 (0)1722 332266

Email: service@naim-uk.com

Please quote the product serial number (found on its rear panel) in all correspondence.

Ariva

5 Introduction and Positioning

Naim loudspeakers are precision acoustic instruments that will only achieve optimal performance if installed and set up carefully. Please read these instructions before installing and using the loudspeakers. Please also retain the packaging for future use.

The performance of any loudspeaker will be influenced by the room in which it is located and even small changes of loudspeaker position can significantly influence the sound. Choose a site where the loudspeakers can be located between 1.2m and 4m apart (4ft and 13ft), clear of room corners, and where each loudspeaker is between 10cm and 60cm (4" and 24") away from a solid back wall. It is not necessary to angle the loudspeakers inwards towards the listening position.

The distance from the back wall is the aspect of positioning most likely to require adjustment as you become familiar with the characteristics of the loudspeakers in your room. Further from the wall the speakers will generate less low frequency energy.

Loudspeakers, like many hi-fi components, will take time to stabilise and "run-in" and can be expected to improve with use even over a period of weeks. For this reason it is prudent not to finalise loudspeaker positioning until they have been operating for at least one week.

5.1 Installation

Stage 1

Each Ariva loudspeaker comprises a separate plinth and cabinet. These components can be identified from the diagrams opposite.

To begin installation, first fit four floor spikes and lock-nuts to the underside of each plinth. Leave just enough spike length extending below the lock nut to account for the thickness of carpet and underlay. Best results will be achieved when the spike length is set to the minimum required for the lock-nuts to sit just above the carpet pile. Do not fully tighten the lock-nuts at this stage.

Note: *If you intend to install the Ariva on a non-carpeted floor the spikes should be used in conjunction with Naim Floor Protectors (see Diagram 6.1) and set up so that just the tip extends beyond the lock nut. Your retailer or distributor will be able to supply Floor Protectors.*

With spikes fitted, but not tightened, place each plinth on the floor in the intended loudspeaker position. Use the supplied allen key, via the access hole in the top surface of the plinth (see Diagram 6.1), to adjust each spike so that the plinth is both level and does not rock. Use a spirit level to confirm the plinth is level and tighten each lock-nut using a 10mm spanner.

Note: *With thick carpet and underlay it can be difficult to ensure that the spikes are resting on the floor. Small slits cut into the carpet once the loudspeaker position is finalised will help.*

Stage 2

Each plinth is fitted with three upward facing decoupling domes. These domes locate in to the corresponding spherical recesses in the underside of the Ariva cabinets. To complete the Ariva installation carefully line-up and lower each cabinet on to its plinth so that it locates securely.

5.2 Connection

If the loudspeakers are to be used with Naim amplification, Naim loudspeaker cable will produce the best results and is necessary with some amplifiers. Cable lengths to both loudspeakers should be equal and be between 3.5 metres and 20 metres (11.5ft and 66ft). Your local retailer will be able to make up cables of the appropriate length.

Connect the loudspeaker cables with their custom Naim plugs to the input sockets located on the rear of each Ariva cabinet. Ensure that each positive plug - identified by a rib on the side of the cable and a tag marked "pos" on the side of the connector body - is inserted to the red input sockets.

6 Installation Diagrams

6.1 Plinth Installation

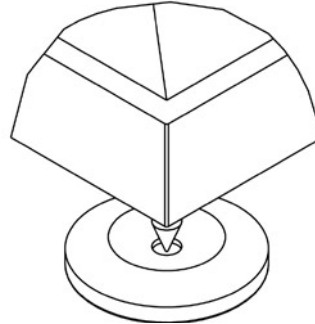
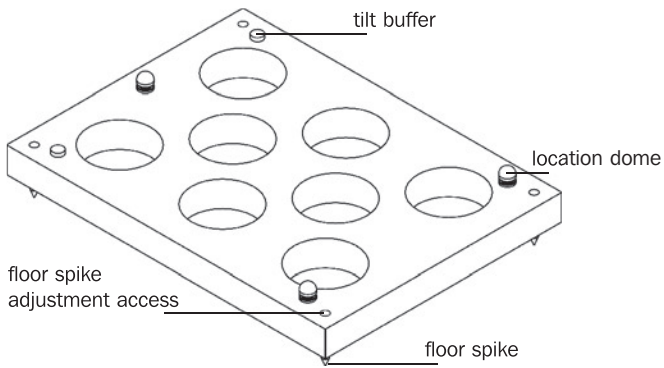

Naim Floor Protectors can be used to if the Ariva is to be installed on a non-carpeted floor.

Use the supplied allen key via the access hole in the top surface of the plinth to adjust the spikes.

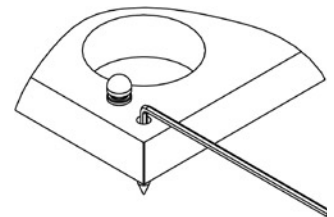

6.2 Cabinet to Plinth Assembly

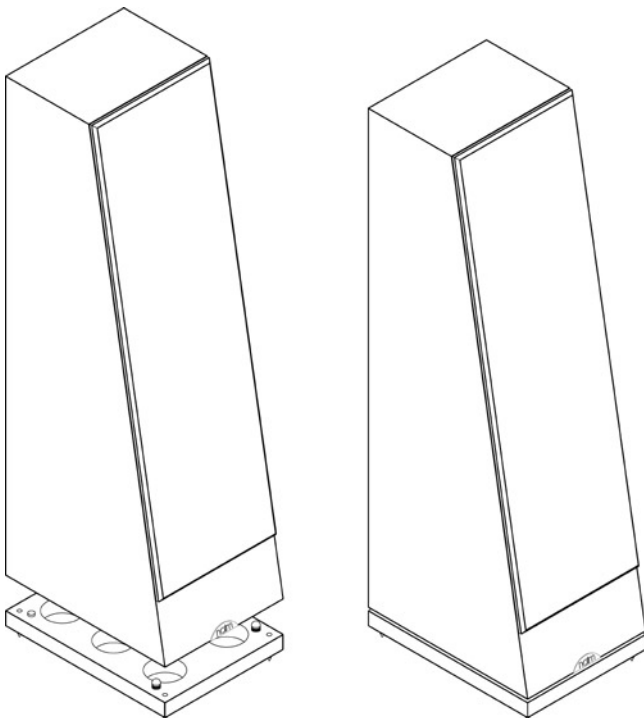

Lower the cabinet on to the plinth. Plinth and cabinet to line-up.

7 Ariva Specification

Frequency Response:	30Hz - 20kHz
Sensitivity:	88dB/1W/1m
Power Handling:	100 Watts (music program)
Impedance:	4Ω (nominal)
Dimensions (H x W x D):	880 x 230 x 310mm
Finishes:	Cherry, Maple, Black