



A-10 OWNERS MANUAL

A-10 LEFT MONITOR SERIAL NUMBER: _____
A-10 RIGHT MONITOR SERIAL NUMBER: _____
A-10 CONTROL AMPLIFIER SERIAL NUMBER: _____

SAFETY INSTRUCTIONS -- PLEASE READ FIRST

CAUTION: To reduce the risk of electric shock, do not remove the cover (or back). No user serviceable parts are inside; refer servicing to qualified personnel.

WARNING: To reduce the risk of fire or electric shock, do not expose this appliance to rain or moisture.



This symbol wherever it appears, alerts you to the presence of uninsulated dangerous voltage inside the enclosure that may be sufficient to constitute a risk of electric shock.



This symbol, wherever it appears alerts you to important operating and maintenance instructions in the accompanying literature. Read the manual.

DETAILED SAFETY INSTRUCTIONS:

All the safety and operation instructions should be read before the appliance is operated.

Retain Instructions:

The safety and operating instructions should be retained for future reference.

Heed Warnings:

All warnings on the appliance and in the operating instructions should be adhered to.

Follow Instructions:

All operation and user instructions should be followed.

Water and Moisture:

The appliance should not be used near water (e.g. near a bathtub, washbowl, kitchen sink, laundry tub, in a wet basement, or near a swimming pool etc.).

Ventilation:

The appliance should be situated so that its location or position does not interfere with its proper ventilation. For example, the appliance should not be situated on a bed, sofa, rug, or similar surface that may block the ventilation openings, or placed in a built-in installation, such as a bookcase or cabinet that may impede the flow of air through the ventilation openings.

Heat:

The appliance should be situated away from heat sources such as radiators, heat registers, stoves, or other appliances (including other amplifiers) that produce heat.

Power Source:

The appliance should only be connected to a power supply of the type described in the operating instructions or as marked on the appliance.

Grounding and Polarization:

Precautions should be taken so that the grounding or the polarization means of the appliance is not defeated.

Power Cord Protection:

Power supply cords should be routed so that they are not likely to be walked on or pinched by items placed upon or against them, paying particular attention to cords and plugs, convenience receptacles and the point where they exit from the appliance.

Cleaning:

The appliance should only be cleaned as recommended by the manufacturer.

Non-use Periods:

The power cord of the appliance should be unplugged from the outlet when left unused for a long period of time.

Object and Liquid Entry:

Care should be taken so that objects do not fall and liquids are not spilled into the enclosure through openings.

Damage Requiring Service:

The appliance should be serviced by qualified service personnel when;

- The power supply cord or the plug has been damaged; or
- Objects have fallen, or liquid has been spilled into the appliance; or
- The appliance has been exposed to rain; or
- The appliance does not appear to operate normally or exhibits a marked change in performance; or
- The appliance has been dropped, or the enclosure damaged.

Servicing:

The user should not attempt to service the appliance beyond what is described in the Operating Instructions. All other servicing should be referred to qualified service personnel.

INTRODUCTION:

Thank you for your selection of the A-10. Your studio monitors are a critical element in the countless decisions made during recording, mixing, mastering and other key aspects of audio production. They must deliver a transparent, neutral and revealing assessment of sound, so that you have the information you need to choose and place microphones, set Eq's, balance mixes... deliver exceptional product. The A-10 is capable of state-of-the-art sonic resolution and flexibility. Investing time to learn about the A-10's features and operation will reward you with the best possible performance.

If you require assistance at any time during or after the setup process, call our Customer Service Hot Line at I-800-NHT-9993 (648-9993).. You can also visit our web site at www.nhtpro.com for more in depth technical information. Thanks again for your confidence in our products!

GETTING STARTED:

The A-10 is a unique system that combines a dedicated control amplifier with loudspeaker monitor cabinets, using controlled impedance cables that actually form part of the crossover network. By designing the system as an integral package in this manner, many of the advantages of self-powered speakers can be realized without attendant performance compromise. However, it must be recognized that the control amp, cables and monitors are an inseparable package.

The A-10 Monitors must only be used with the A-10 Control Amp and cables, and vice versa.

The following are included in the Control Amplifier carton:

- | | |
|------------------------------------|------------------------------------|
| 1 ea. - Control Amplifier | 2 ea. - 20' Monitor Output Cables |
| 1 ea. - 6' IEC Power Cord | 4 ea. - IO-32 Rack Mounting Screws |
| 1 ea. - Warranty Registration Card | 8 ea. - Plastic Insulating Washers |

The A-10 Control Amplifier may be used on a shelf, or mounted in a standard 19" equipment rack using the screws and washers supplied. For rack mounting, remove and retain the four feet from the bottom of the amp chassis using a #2 Philips screwdriver. Two vertical rack spaces are required, but we recommend you leave at least one additional open space above and below the A-10 for improved cooling, as you would with any high power amplifier. For table or shelf use, the four feet must remain attached to allow for air circulation. As a starting point for speaker placement, align the back of the enclosures parallel to the rear wall, with the angled fronts facing in towards you. For more detailed speaker placement information, see page 7.

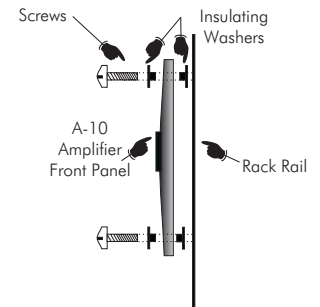

Fig. 1: Rack Mounting Detail

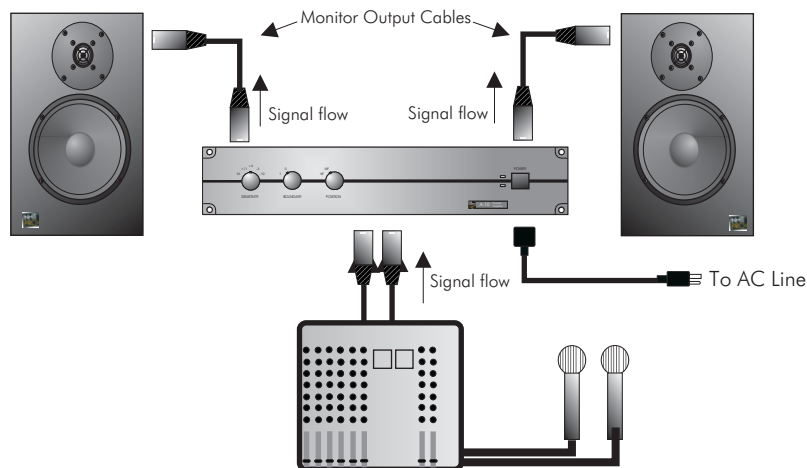

Fig. 2 Typical System Configuration

SYSTEM CONNECTIONS:



CAUTION: MAKE ALL CONNECTIONS WITH THE AC POWER OFF!



CAUTION: CONNECTING THE OUTPUT OF THE A-10 CONTROL AMPLIFIER TO ANY EQUIPMENT OTHER THAN THE A-10 MONITOR MAY CAUSE EQUIPMENT DAMAGE.

CONTROL AMPLIFIER INPUT SECTION: The A-10 Control Amplifier accepts both balanced and unbalanced inputs on either XLR or 1/4" TRS connectors. These connectors are hardwired in parallel within the A-10 to allow for convenient equipment chaining, but only one signal source should be physically connected to the unit at any time. Figure 3a indicates proper wiring protocol for each type of connector. Since there are many different connector types and signal levels employed by source equipment, some experimentation may be necessary, keeping in mind that A-10 can accept a wide range of signals and has an input sensitivity control on the front panel.

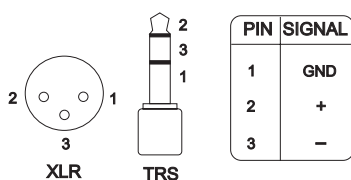

Fig. 3a Balanced Wiring Diagram

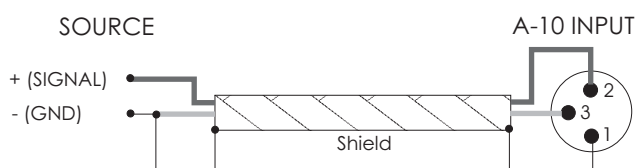

Fig. 3b Unbalanced Wiring Diagram

SPEAKER CABLE CONNECTIONS: The A-10 includes two 20' special purpose cables to connect the Control unit to the Monitors. While these cables look similar to standard microphone cables, they are constructed with lower and more consistent conductor impedance. Portions of the A-10's crossover circuitry are located in both the amplifier and speaker enclosures, and the cables supplied are an important part of this electrical network. This allows the speaker cables to function as a neutral and transparent component in the system. Replacing or extending the supplied cables with any other type will have a varying, and only partly predictable impact on the sound of the A-10. If your installation requires the use of alternative cables, you may consult the supplied table listing our measurement data on a variety of cable types. Be sure they are wired as shown in Fig. 3a. These considerations aside, using the supplied NHTPro cables to connect the control amplifier is quite simple and straight forward. Both the amplifier and the monitors are marked with the appropriate "left" and "right" channels. Fit the XLR connectors into the corresponding connectors on the control amplifier and monitors until the connector locks.



WARNING: IF USING CABLES OTHER THAN THOSE SUPPLIED WITH THIS SYSTEM, BE SURE THAT NO CONDUCTOR IS WIRED TO THE XLR CASING. FAILURE TO DO SO MAY CONSTITUTE A RISK OF ELECTRIC SHOCK.

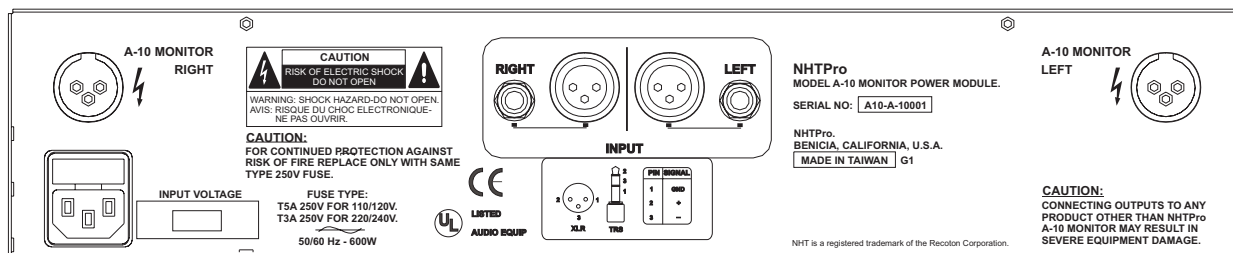

Fig. 4 A-10 Control Amplifier Rear Panel

USING THE A-10 CONTROL FUNCTIONS:

The A-10 controls are designed for utility and repeatability under varying conditions. You should find the effects of the controls sonically subtle, with little impact on the basic character and accuracy of the speaker. We encourage experimentation to fine tune the system to the requirements of your particular installation.



Fig. 5 A-10 Control Amplifier Front Panel

POWER INDICATORS: Just to the left of the power switch on the A-10 Control Amplifier are two power related LED's. The upper (green) LED lights up indicating there is AC power to the amplifier and the POWER SWITCH is in the "on" position. The lower (red) LED indicates a clipping or overload condition. Occasional flashing of this indicator is a gentle warning you are reaching the system's limits. If the red LED glows continually, severe clipping is occurring. The input signal or system gain should be reduced to avoid the risk of possible system damage.

SENSITIVITY: This control is used to change the input sensitivity with settings at; -10dB, -3dB, +4dB, +11dB and (M)ute providing noise free, consistent gain matching with a wide variety of equipment. The proper setting is the lowest sensitivity possible (highest dB number) which allows the speaker to reach the maximum desired output without source clipping. Professional devices typically spec full output at +4dB, most consumer audio products reach full output at -3dB, and most computer sound cards have a full scale output of -10dB. Consult the owner's manual for the device connected to the Control Amplifier for its output level specifications and set the SENSITIVITY switch accordingly.

BOUNDARY CONTROL: Reflective boundaries, such as floors, walls, even table tops, reinforce a speaker's low frequency output. Conversely, placing speakers out into a room decreases bass response. The greatest low frequency output is with the BOUNDARY control in the "0" position, which assumes no significant boundary reinforcement is present. The control attenuates low frequencies by 3 dB (at 50 Hz), with rapidly decreasing effect above 300 Hz. Refer to the diagram in Fig. 6 for information on setting the control appropriately.

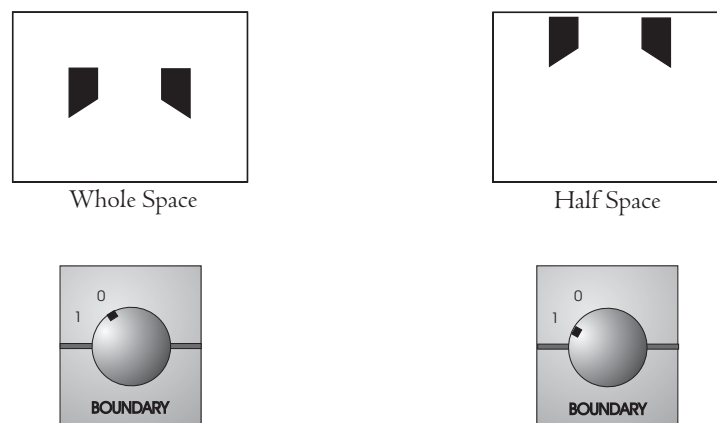

Fig. 6: Boundary Control Settings Diagram

POSITION CONTROL: Close in monitoring, sometimes referred to as “near-field” reduces the effect of room acoustics on the signal, and provides great detail. Mid-field listening reveals aspects of recorded ambience and is more representative of end use. However, a speaker’s upper frequency power response changes with distance, due to room influences and air absorption. The A-I0 may be adjusted for flat response at two listening distances. The maximum high frequency output is obtained with the control in the “FF” (far-field) position. In the near-field, the control attenuates 20 kHz by 2.5 dB, with no effect on frequencies below 3 kHz. See Fig. 7 for the appropriate POSITION control setting based on listening distance.

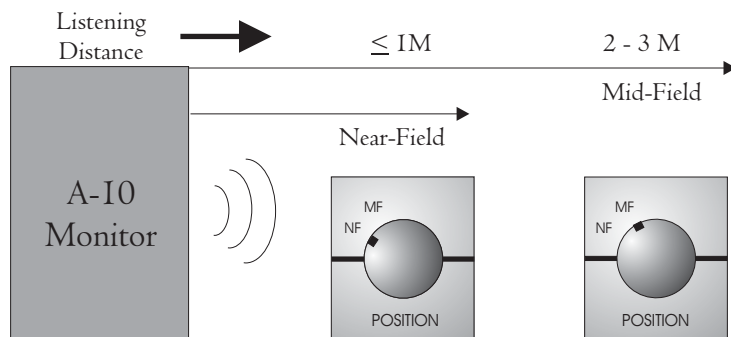

Fig. 7 Position Control Settings Diagram

SPEAKER PLACEMENT:

The A-I0 is intended to provide consistent performance over a wide range of placement situations. This is accomplished through the use of electrical controls, wide dispersion drivers, advanced enclosure design and carefully chosen crossover characteristics. Nevertheless, it is always worth investing time and effort experimenting with optimum loudspeaker placement. In all cases, A-I0 Monitors should be set up symmetrically equidistant from the listening position; the left speaker and right speaker should be at the same relative positions with respect to the primary listening area. This is important in order to hear a proper stereo sound stage. The speaker baffles angle in towards the listening position with the loudspeaker backs parallel to one another. A good starting point can be found in Figure 8 below. Ideally, the tweeter height should be on axis with your ears, or slightly above. Also, remember that nearby reflective surfaces can alter impulse response and blur imaging and tonality.

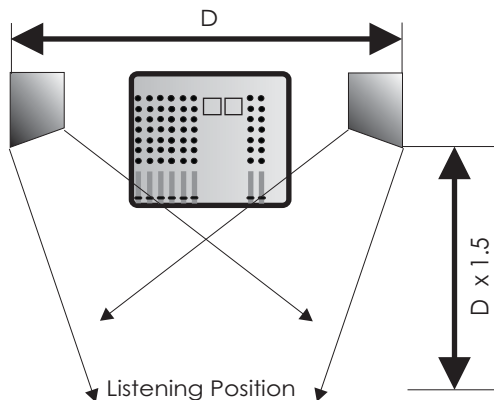

Fig. 8 Ideal Monitor Placement

SYSTEM OPERATION:

The A-10 is capable of very high output levels, especially when listening in the near-field. Still, every speaker system has its limits. Protect your ears and use common sense. Harsh breakup at extremely high volume, or heat emanating from the drivers is an indication that the system has exceeded its output limits and you should lower the playback level. And watch for excessive lighting of the amplifier front panel clipping indicator. Speaker damage most often occurs from sustained high volume levels, not from transient sounds or brief musical peaks.

A-10 STUDIO MONITOR SYSTEM CARE:

Except for the occasional flattering comment, your A-10 needs no regular maintenance. Never attempt to clean the A-10 Monitor driver units except for very light feather dusting. The A-10 Monitor cabinet and the A-10 Control Amplifier front panel can be cleaned using a damp, soft cotton cloth first sprayed with a mild, nonabrasive glass cleaner. Never spray the speaker or amplifier directly! Avoid silicone or oil based cleaners or treatments.

NEED HELP?

Technical Support can be reached several ways: Telephone us toll-free at (800)-NHT-9993 (648-9993), E-mail us at: Tech@nhtpro.com, Fax us at: (707) 747-1252 or write us at: NHTPro, 6400 Goodyear Rd. , Benicia, CA 94510. Or visit our web site at www.nhtpro.com.

SYSTEM SPECIFICATIONS:

Type: Modular, two piece powered near/mid field monitor.

Configuration: 2-way acoustic suspension.

Woofers: 6.5" treated paper.

Tweeter: 1" soft dome.

Magnetic Shielding: Full.

PERFORMANCE SPECIFICATIONS:

Amplifier Power: 150W (continuous RMS/ch), 300W (100ms peak).

Peak Acoustic Output: 116 dB SPL (100ms pink noise @ 1M).

Residual hum/noise: <10 dB SPL (A weighted @ 1M).

THD @ 90 dB SPL: <0.8% (100Hz ~ 10kHz @ 1M).

System Response +/- 2 dB (1/3 oct. swept noise): 57Hz ~ 20kHz @ 1M, 55Hz ~ 20kHz @ 2M.

-6dB LF cutoff: 50Hz (inroom response).

Loudspeaker Dimensions/Wgt.: 11.9" h x 7.5" w x 10.7" d/ 14 lbs.

Loudspeaker Materials: 0.75" MDF w/high pressure laminate (internal + external).

Control Amplifier Dimensions/Wgt.: 3.5" h x 19" w x 13.25" d/32 lbs.

FEATURES/CONTROLS:

Connectors:

Input: XLR, TRS.

Output to monitor: XLR.

Controls:

Sensitivity: 5 position (-10dB, -3dB, +4dB, +11dB, Mute).

Wall proximity (Boundary): 2 position (0.0, 1.0).

Listening Proximity (Position): 2 position (near/mid).

Power: On, off.

LED Displays(2):

Power.

Overload.

NHTPRO
6400 Goodyear Road
Benicia, CA 94510
ph: (707)748-5940
fx: (707)747-1252
www.nhtpro.com