

**20|06**  
anniversary edition  
**TWEN**

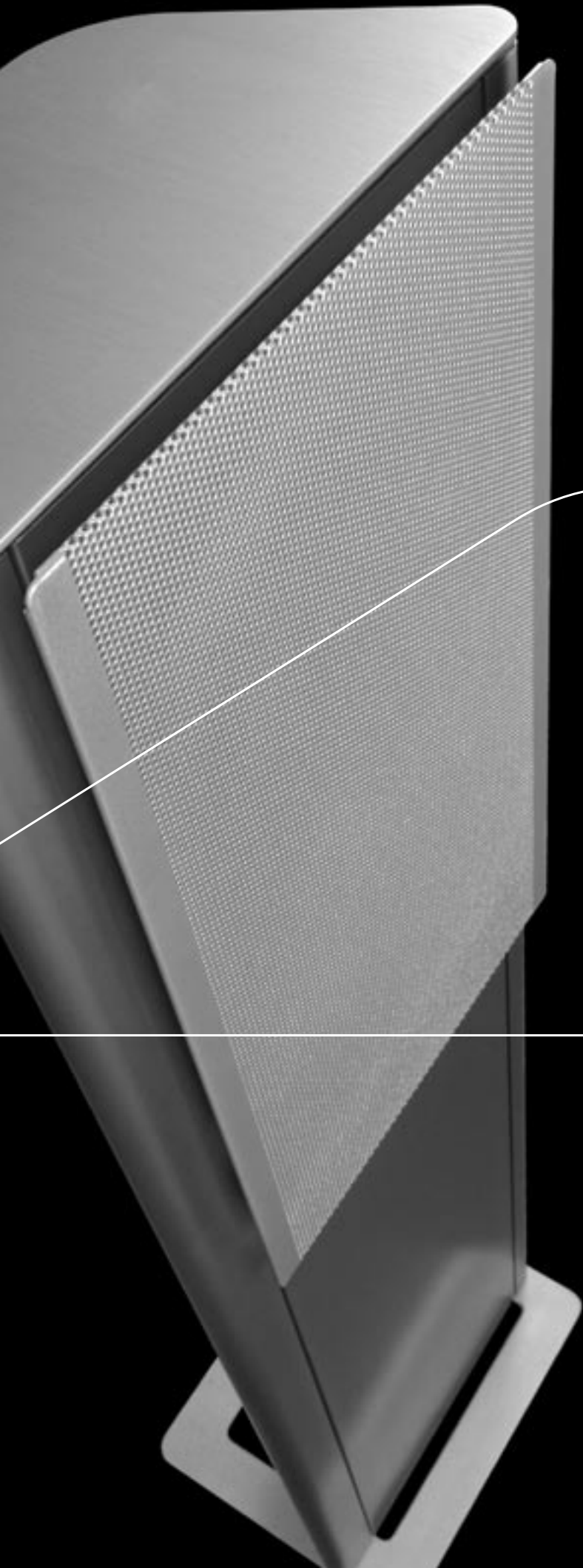

**PIEGA**  
SWITZERLAND

**1986**



first PIEGA ribbon tweeter

**1986**



first series piano cabinet

**1991**



first 2-way ribbon system

**1993**



first steel/MDF cabinet

**1997**



first extruded aluminum cabinet

**2000**



first coaxial ribbon system

**2000**



first sand cast aluminum cabinet

**2002**



first small coaxial ribbon system

**2003**



first MDF/aluminum cabinet

**2006**



first extruded aluminum sandwich cabinet

## PIEGA 20 Years of Innovation

Founded in 1986, PIEGA SA set out to develop ribbon technology to the current state of the art. PIEGA pioneered the field of ribbon tweeters, and with innovative ideas and the use of the latest materials succeeded in developing the LDR (Linear Drive Ribbon) ribbon. This tweeter system was the first system based on the ribbon principle that fully utilized all the benefits of the design without having to accept any of the more «historical» disadvantages.

News about the exceptional quality of this tweeter system spread like wildfire amongst the most discerning audiophiles. Equally extraordinary for those times was the fact that PIEGA was offering highly attractive and perfectly finished series loudspeakers with real piano lacquer.

These foundations of PIEGA SA's history resulted in constant further developments in the years that followed. The continuous further development of the ribbon technology led the ribbon midrange and finally to the world's first coaxial ribbon system. This system was used for the first time in the C40 in 2000 and represents a milestone in the history of loudspeaker development.

At the same time PIEGA also pioneered new ways in the construction of loudspeaker cabinets. From the first metal constructions using compounds, cabinets were developed with an individual and unmistakable signature. The first extruded aluminum cabinets, sand cast cabinet and finally the first double-walled aluminum cabinet are PIEGA innovations.

Over the years, the name PIEGA grew more popular amongst audiophiles around the world and became synonymous with quality and innovation. Reports in the audio media worldwide continue to emphasize the high standards that PIEGA achieves. The two founders will also continue in future to advance the development of new ideas and concepts in loudspeaker design.



Leo Greiner



Kurt Scheuch



## PIEGA **Twen**

The PIEGA Twen is the special model for the company's twentieth anniversary – an elegant unit in titanium for uncompromising listening enjoyment. It is based on the asymmetrical profile of the AS/AP models, and offers an inspiring alternative in the loudspeaker market. The elegant shape, from the drawing board of well-known Swiss designer Hannes Wettstein, produces an ideal combination of the technical and aesthetic features of a loudspeaker. The triangular footprint guarantees reflection-free acoustic behavior and thus the basis for authentic musical integrity. The attractive design allows the loudspeakers to be perfectly matched in any living room. Elegant, timeless and shaped to perfection.

Thanks to the unique MDS® technology (Maximum Displacement Suspension) of the new bass chassis, these stylish loudspeakers offer an outstanding performance. The accurately dimensioned aluminum cabinet, in perfect combination with a precision-designed frequency crossover and the legendary PIEGA LDR ribbon tweeter produce a uniquely beautiful sound. Its slim-line appearance is bound to cause astonishment as soon you appreciate the impressive authority with which the PIEGA Twen reproduces large orchestral works. Energy-based and progressive music or even soft sounds for dreaming are both delivered with compelling quality. The absolutely natural musical integrity of all musical directions offers the senses enjoyment every day anew.

The titanium finish elegantly emphasizes the high quality technology and immaculate finish. PIEGA Twen, a special model in a uniquely elegant and limited edition.



# Technical Data

Model	<b>Twen</b>
Design principle	2 1/2 - way column loudspeaker
Recommended amplifier output	20 – 150 Watt
Sensitivity	90 db/W/m
Impedance	4 Ohm
Frequency range	45 Hz – 50 kHz
Equipment	2 10 cm MDS® bass 1 LDR ribbon
Connection	WBT
Dimensions (HxWxD)	101 x 25 x 12 cm
Weight	18 kg
Finish	Titan-Finish

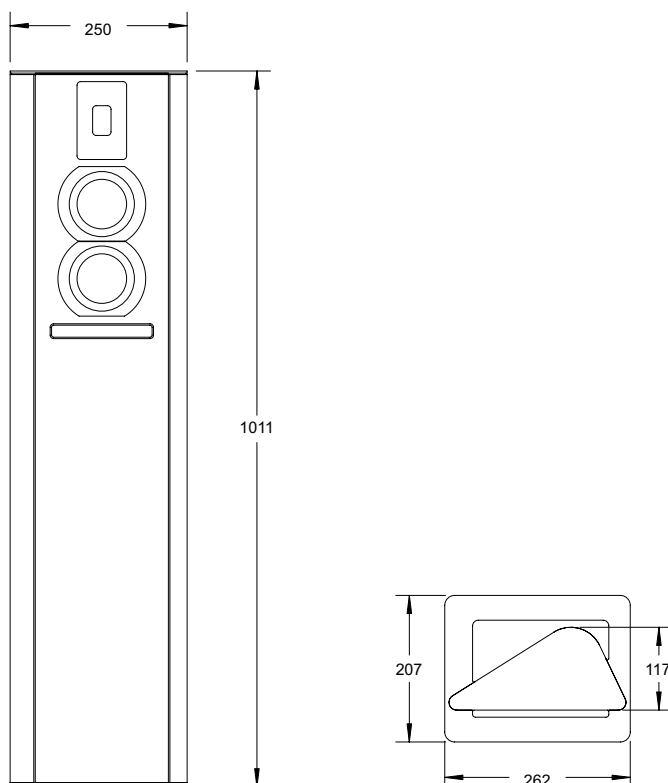

## Service

PIEGA offers first-class service and six years warranty on all loudspeakers, as well as three years on the electronics.

PIEGA SA  
Bahnhofstrasse 29  
CH-8810 Horgen  
Telephone +41 44 725 90 42  
Fax +41 44 725 91 92  
mail@piega.ch  
www.piega.ch

### Information for Exports

PIEGA SA  
Bahnhofstrasse 29  
CH-8810 Horgen  
Telephone +41 44 725 90 02  
Fax +41 44 725 91 92  
mail@piega.ch  
www.piega.ch

Published Summer 2006  
Subject to modifications, in particular  
technical modifications and errors

