



 *the Sonus faber*

S E

Paul Rosson



 *the Sonus faber*

First released in 2009, "The Sonus faber" represents the most ambitious concept ever brought to life by the Vicenza based company.

It was designed without compromise to be the very best representation of the ideals, legacy and vision of the brand.

Countless man-hours, several years of development and the most advanced technologies were poured into it.

The result was beauty beyond expectation, an exquisite expression of rich tradition and cutting-edge innovation.

A MASTERPIECE REVISED

"The Sonus faber SE" is a limited edition rendition of this masterpiece available only by special request from premier clientele. This new 'off the menu' revision features a full overhaul with our latest developments in driver and crossover technologies. It benefits from the most current knowledge and the very best components available in the world. The culmination of these cutting-edge updates has resulted in a loudspeaker which significantly improves upon its predecessor and renders a new level of emotional immersion and ethereal clarity, a beauty which once again exceeds expectation.





"Sonus faber is a dream of pure passion.
Research is the essence of the company.
The approach is scientific, but the goals are emotions and music.
The Sonus faber is the non plus ultra of our dream.
A concentrate of experience, intuitions, hard work and design
that finds its meaning in making the music more vivid, natural and captivating".

Paolo Tezzon, Sonus faber R&D Manager.

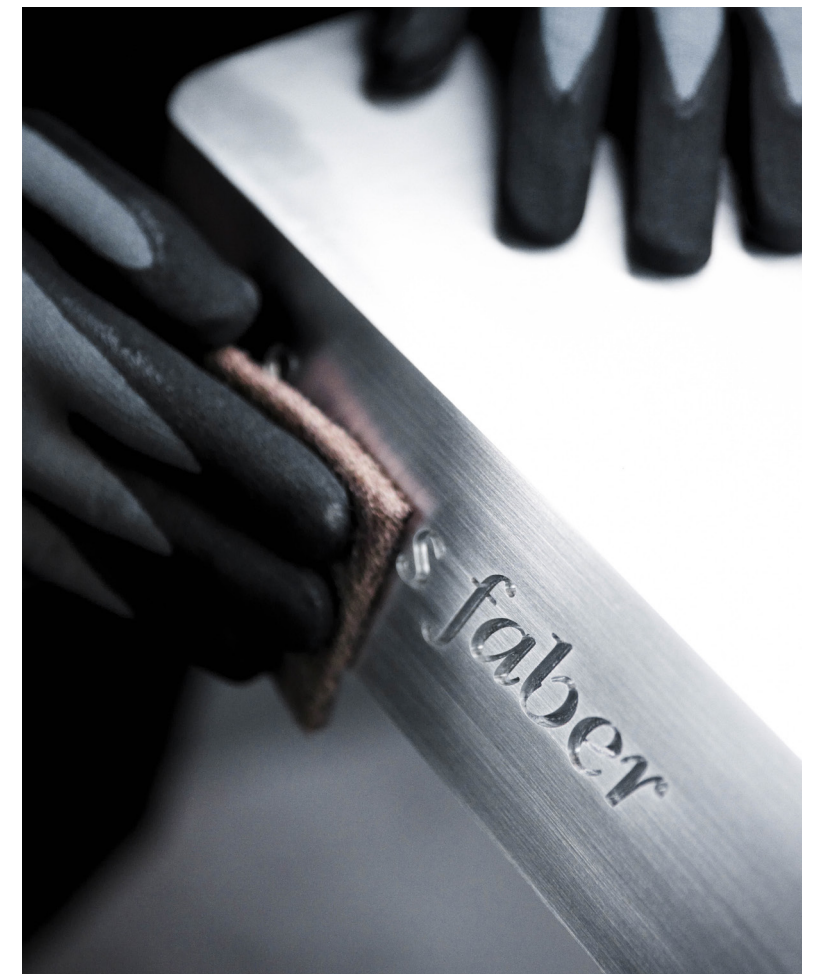
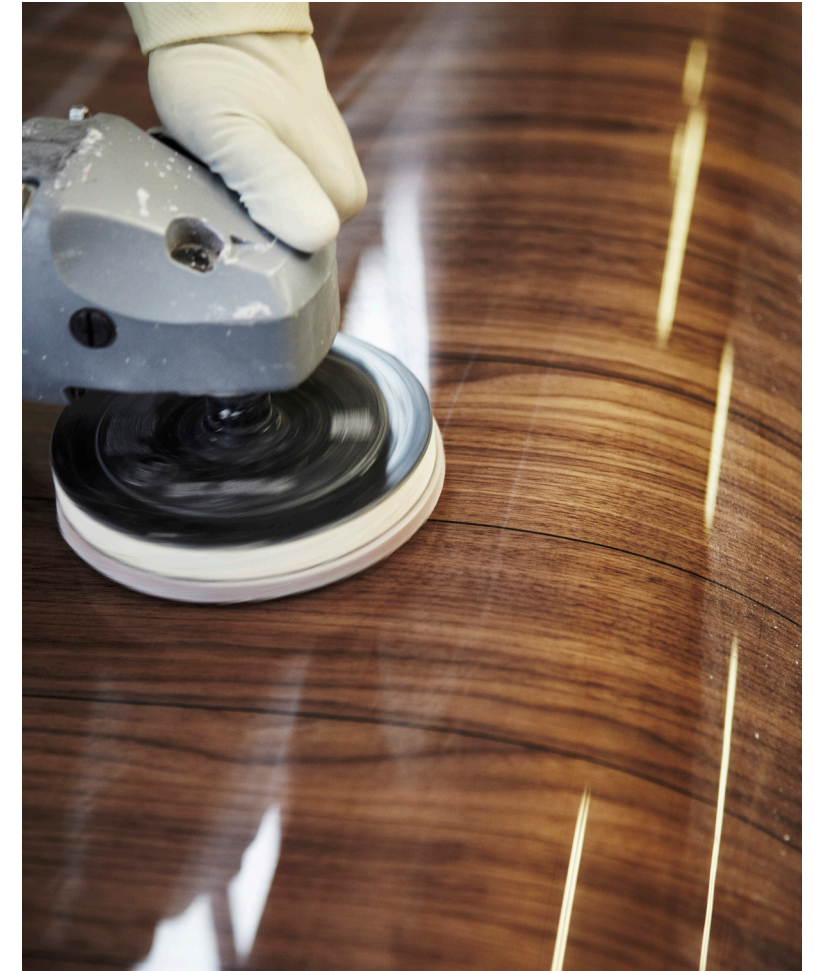



FEATURES

THE "POLAR CLAMSHELLS", THE "ANIMA LEGATA" AND THE "TUNE MASS DAMPER":

the two lyre-shaped elements (upper and lower), machined from solid avional billets, have been designed to collect vibrations like radar paraboloids.

The clamshells are connected by compression through the "Amina Legata (Soul Pole)", a non-magnetic steel alloy shaft and are optimized one by one in traction with a dynamometric device.

The "Amina Legata" in the critical nodal points is implemented with the "Tuned Mass Damper", a device used in both the highest skyscrapers in the world as in F1 cars to eliminate any residual vibration. The system works through anti-phase oscillation, using kinetic-thermal conversion.

Z.V.T. ZERO VIBRATION TRANSMISSION:

the dampening system that inhibits the mechanical transmission of vibration to the environment while eliminating spurious resonance and acoustic feedback.

SILENT CASE:

the double walls in layered Okumè wood are shaped with a dual curvature and decoupled by a constriction damped visco-insulating layer.

The dual curvature increases rigidity compared to previous techniques while the damping eliminates the last traces of resonance.

THE "STEALTH REFLEX":

the para-aperiodic tuning system, besides the usual advantages of reduced dimension, extended low-frequency extension and reduced distortion, has the added benefit of eliminating spurious noises the are typical of traditional reflex systems.

SOUND FIELD SHAPING TECHNOLOGY:

the direct/indirect radiation balance has been addressed innovatively.

A second, mechanically isolated loudspeaker system allows calibration of dimensionality by setting the optimum ratio between the direct and reverberant field. This allows an unparalleled sense of immersion in any listening environment.



THE SONUS FABER SPECIAL EDITION

All new tweeter and mid-range drivers utilizing Sonus faber's latest research in transducer technology.

The Tweeter inherits the knowledge gained with the Ex3ma project, with a neodymium motor system and a dome diaphragm in D.L.C. (Diamond like Carbon) Beryllium.

This is implemented with a CNC machined highly optimized Ergal acoustic labyrinth rear chamber, a mechanical anti-resonator designed specifically for this application.

The Midrange is the same as used on Il Cremonese and Liliun, upgraded with a special basket thoroughly optimized to eliminate any resonance, fully CNC machined from solid billets of Avional and Gun Metal.

The enclosure acoustic loading has been further optimized.

The Cross-over has been completely re-designed using the anechoic chamber in the Sonus faber laboratories and has been upgraded with the new "Paracross topology" present in the latest reference projects.

Cutting edge electrical components have been used throughout the new crossover: latest generation Mundorf "Supreme Evo" Oil, Silver/Gold/Oil capacitors, Jantzen Wax Coil inductors, etc.



TECHNICAL SPECIFICATION



SYSTEM:

3.5 way, sound field shaper variable geometry radiation, vibration cancellation optimized system, stealth reflex vented box, loudspeaker system.

CABINET:

"Lyre shape" design, dual side curvature, special cross grained okumè plywood, used in a double thickness constriction layer damped configuration, has significant advantages compared to the single curvature variant used previously, in terms of low coloration.

Sub-structural plywood ribs are strategically placed for total rejection of spurious vibrations and standing waves control.

"Anima legata" system, based on two clamshells, i.e. CNC anodized machined avional "vibration conveyors" (on the top and on the bottom of the cabinet) that "collect" the remaining structural micro-vibrations coming from the cabinet walls and the transducers, like the parabola of an antenna. The two clamshells are rigidly connected by a special steel rod, a high speed mechanical interface, the "Soul Pole", that concentrates the micro-vibrations to the "Multiple Tuned Mass Damper", a special custom device optimized to critically damp structural resonances, by oscillating in anti-phase.

The enclosure is decoupled from the floor through a patent pending suspension system, eliminating any acoustic feedback and any vibration transmission to the listening room.

TWEETER:

High frequencies are reproduced by a 30 mm moving coil driver, with Sonus faber's vibration optimized mechanical interface, D.L.C. (Diamond Like Carbon) Beryllium dome diaphragm for maximum resolution, visco-elastically decoupled from the main baffle board.

It is implemented with an ergal acoustic labyrinth rear chamber, with a mechanical anti-resonator designed for this application.

MIDRANGE:

A Sonus faber designed 180 mm neodymium magnet system ultra dynamic linearity midrange. CCAW wire is used on a composite former "eddy current free" voice coil. The dynamically linear magnetic field motor incorporates triple Kellogg/Goeller rings. A special custom diaphragm is made with a real time air dried non pressed blend of traditional cellulose pulp, kapok, kenaf and other natural fibers, developed according to the most natural sound.

To further inhibit any residual cone coloration we are using a transparent viscous surface damping coating.

The basket of this unit has been thoroughly optimized to eliminate any resonance and it is fully CNC machined from solid billets of Avional and Gun metal. The combination of the 2 different metals allows to eliminate any mutual resonance.

The same way as the tweeter, the midrange is decoupled from the main baffle board.

WOOFERS:

260 mm woofers with a "sandwich" cone structure, high-tech syntactic foam core and two external surface skins of coated cellulose pulp.

Designed to blend perfectly with the special midrange, and at the same time to have absolute definition in their range: the sandwich structure with outer paper pulp skins has the same sonic character of the midrange cone.

3" voice-coils on Kapton former allow an unlimited dynamic performance and low hysteresis.

INFRA WOOFER:

380 mm infra woofer sandwich cone structure with high-tech syntactic foam core and two external surface skins in nano carbon fibre for maximum rigidity and light weight.

4" voice-coil optimized to have progressive damping, through the use of both Kapton and Avional in the former, to control the Lorentz currents proportionally to the excursion obtaining this way the tightest available lows.

To perfectly match the low-end performance to different listening rooms it is possible to adapt the SPL of the infra woofer.

SOUND FIELD SHAPER:

Special patented Sound Field Shaping technology allows the control of the direct/reverberant radiation of the Sonus faber.

The sound field shaping module can be optimized in terms of azimuth and SPL.

SOUND FIELD SHAPER TWEETER:

29 mm ultra dynamic linearity neodymium ring radiator dome derivative driver. Optimized off-axis radiation for this special application.

SOUND FIELD SHAPER MIDRANGE:

120 mm neodymium hexadyne magnet system, paper pulp/papyrus/natural fiber cone driver, as used for the front midrange.

It is a classic Sonus faber choice, a 4th generation derivative of the unit used on the original Minima.

CROSSOVER:

Completely re-designed Non-resonant Crossover, optimized amplitude/phase response for optimal space/time performance.

"Paracross topology" for maximum transparency.

The impedance at low frequencies is controlled for a clear and friendly amplifier performance.

Double staggered transfer function low frequency/room interface optimized filter.

Highest quality is used in terms of the components: last generation Mundorf "Supreme Evo" Oil, Silver/Gold/Oil capacitors, Jantzen "Wax coils" inductors. Cross-over: 80Hz - 250 Hz - 2500Hz.

FREQUENCY RESPONSE:

18Hz – 36000Hz, Stealth reflex included.

SENSITIVITY:

92 db spl (2.83V/1m).

NOMINAL IMPEDANCE:

4 ohm.

POWER HANDLING:

100W - 1KW, without clipping.

DIMENSIONS (HXWXD):

68.9" x 29.5" x 30.9"

1750 x 750 x 875 mm

WEIGHT:

1,355.8 lb / 615 kg per pair – net weight

1,635 lb / 742 kg per pair – shipping weight.

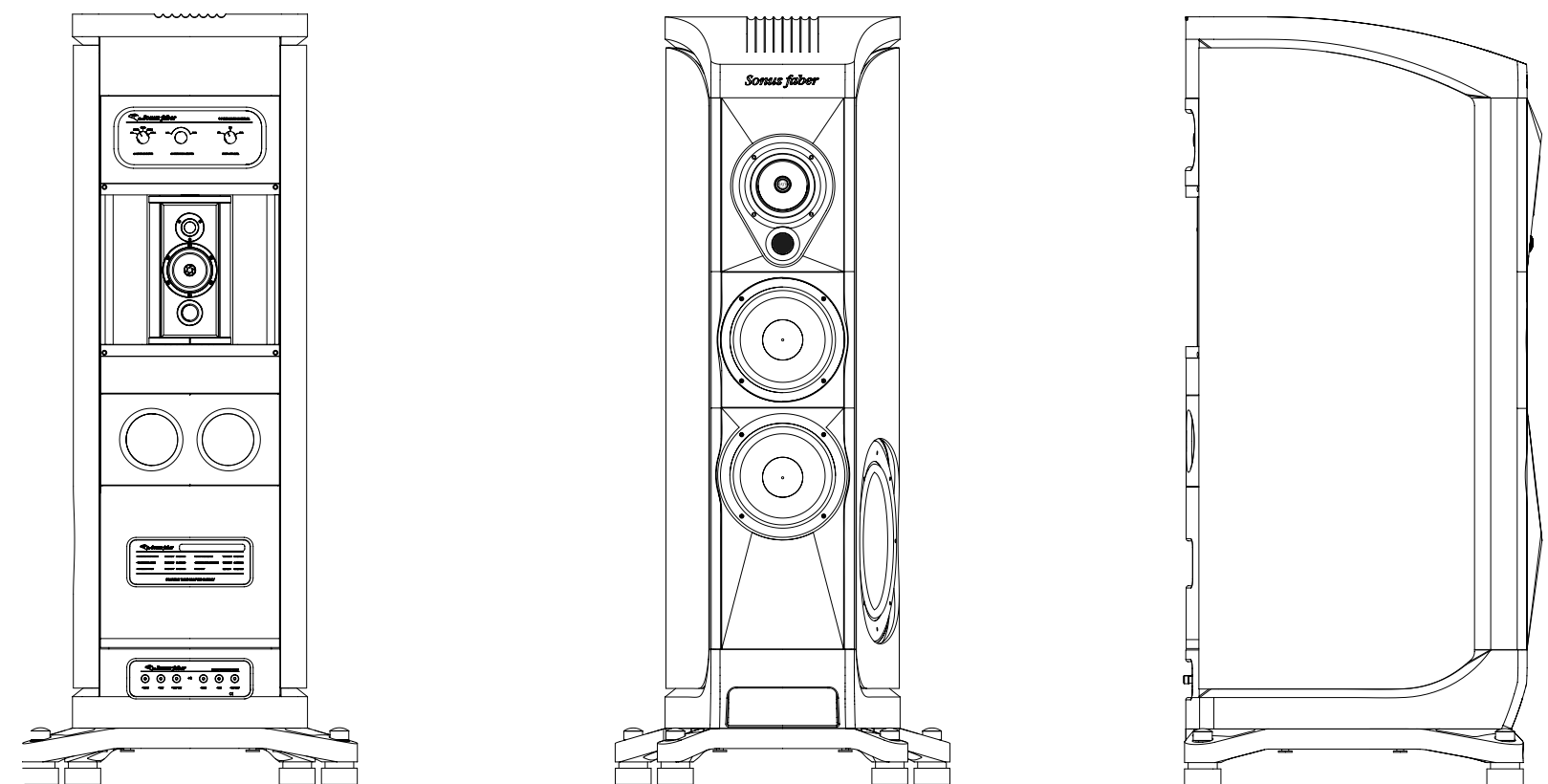



Sonus faber

sonusfaber.com