



*Thank you for choosing EMM Labs*

Welcome	002
Table of Contents	003
Safety Instructions	004
Warranty	005
DV2 Integrated Converter	006
Features & Specifications	007
Front Panel & Functions	009
Rear Panel & Functions	010
Operation	012
DSD, DXD and MQA® Audio	019
Infrared Remote Control	021

## Safety Instructions

Prior to installing your new EMM Labs product please read the following safety instructions:

- Read and follow all instructions.
- Keep these instructions.
- Do not use or install product near any sources of water, rain and/or moisture.
- Clean using only a dry cloth.
- Install only in accordance with the manufacturer's instructions.
- Refer all servicing to approved service personnel.
- Do not install near any heat sources such as radiators, heat registers, stoves, or other apparatus (including amplifiers) that produce heat.
- Do not install product outdoors or in direct sunlight.
- Leave at least 10cm or 4 inches around product to ensure proper ventilation.
- Do not place product near strong electrical or magnetic radiation/emissions or near a power amplifier.

This EMM Labs product must be connected to a mains socket outlet with a protective earthing connection (grounding pin).

**WARNING:** TO REDUCE THE RISK OF FIRE OR ELECTRIC SHOCK, DO NOT EXPOSE THIS APPARATUS TO WATER OR MOISTURE.

**EEC:** This product has been designed and tested to comply with the limits set out in EN55013, EN55020 and EN 60065:2009 (electrical safety).



## Warranty

EMM Labs warrants the DV2 product against defects in material and workmanship under normal use and service for a period of time specified by the product's serial number from the date of first delivery to the owner. The warranty time period is 5 years. Warranty is limited to the original owner and is non-transferable.

EMM Labs will pay for return shipping charges back to the owner when the product is sent to EMM Labs within the first 90 days after purchase (US and Canada end-users only). Otherwise, owner will be responsible for all shipping charges to and from EMM Labs.

For all warranty claims, a copy of the original invoice must accompany the product.

Opening the product or modifying it in any way by the owner, including but not limited to cryogenic treatment, will void any warranty.

Please contact EMM Labs ([support@emmlabs.com](mailto:support@emmlabs.com)) for RMA number and shipping instructions before shipping any product to EMM Labs.

EMM Labs products are sold worldwide through authorized dealers with restricted territories. EMM Labs product purchased from non-authorized dealers or from a dealer selling outside his / her authorized territory will automatically void product warranty.

## DV2 INTEGRATED CONVERTER

The DV2 builds on EMM Labs ground breaking DAC technology used in our multi-award winning flagship DA2 converter.

The DV2 features EMM's newly developed high resolution volume control system, VControl™. VControl™ is completely transparent at any volume setting and has wide attenuation range. Along with a multitude of inputs, the DV2 also supports DSD, 2xDSD, DXD, and includes MQA® technology, enabling playback of MQA® audio files and streams via USB Audio, delivering the sound of the original master recording.

The DV2 has:

- 16xDSD proprietary discrete dual differential (MDAC2™) D-to-A converters
- New high resolution volume control system (VControl™) with High/Low output gain control
- Latest generation 16xDSD Meitner Digital Audio Translator (MDAT2™) signal processing technology
- Latest generation enhanced MFAST™ technology for instant signal acquisition and jitter-free performance
- Next generation MCLK2™ proprietary master clock
- New USB interface with hardware galvanic isolation
- 24bit,192kHz and DSD support on all inputs DSD, 2xDSD, DXD (352/384kHz) and MQA® full decoding over USB
- Exclusive aerospace-grade ceramic circuit boards
- Supports DSD for CD/SACD playback over EMM Outilink
- Polarity inversion performed in the digital domain
- USB port for future software upgrades

## Features & Specifications

### *2-Channel D/A conversions:*

- from PCM (44.1kHz, 48kHz, 88.2kHz, 96kHz, 176.4kHz, 192kHz) and DSD to analog
- from 352DXD, 384DXD, DSD, 2xDSD and full MQA<sup>®</sup> decoding to analog via USB
- from 44.1kHz and DSD to analog via EMM Optilink (SACD/CD playback)

### *Supported digital input formats:*

- AES/EBU
- Two COAX SPDIF
- Two TOSLINK SPDIF
- EMM Optilink
- USB Audio

### *Analog outputs and impedances:*

- Balanced on XLR (300Ω)
- Unbalanced on RCA (150Ω)

### *Output levels (High/Low):*

- XLR outputs: 7.0/5.0V (+19.1/16.2dBu)
- RCA outputs: 3.5/2.5V ((+13.1/10.2dBu)

### *Note:*

1. XLR analog outputs are balanced with pin 2 hot, pin 3 cold and pin 1 ground.
2. For proper digital audio data transfer (especially high resolution PCM and DSD) appropriate high quality TOSLINK, SPDIF, AES and USB 2.0 cables must be used.

## Features & Specifications

*System control* via Infrared remote and serial RS-232 ports

*Power supply:*

- Power factor corrected
- Factory set to 100V or 115V or 230V, 50/60Hz operation
- Power consumption: 30W
- Dimensions W x D x H: 438 x 400 x 161mm
- Weight: 17.2kg

## Front Panel &amp; Functions

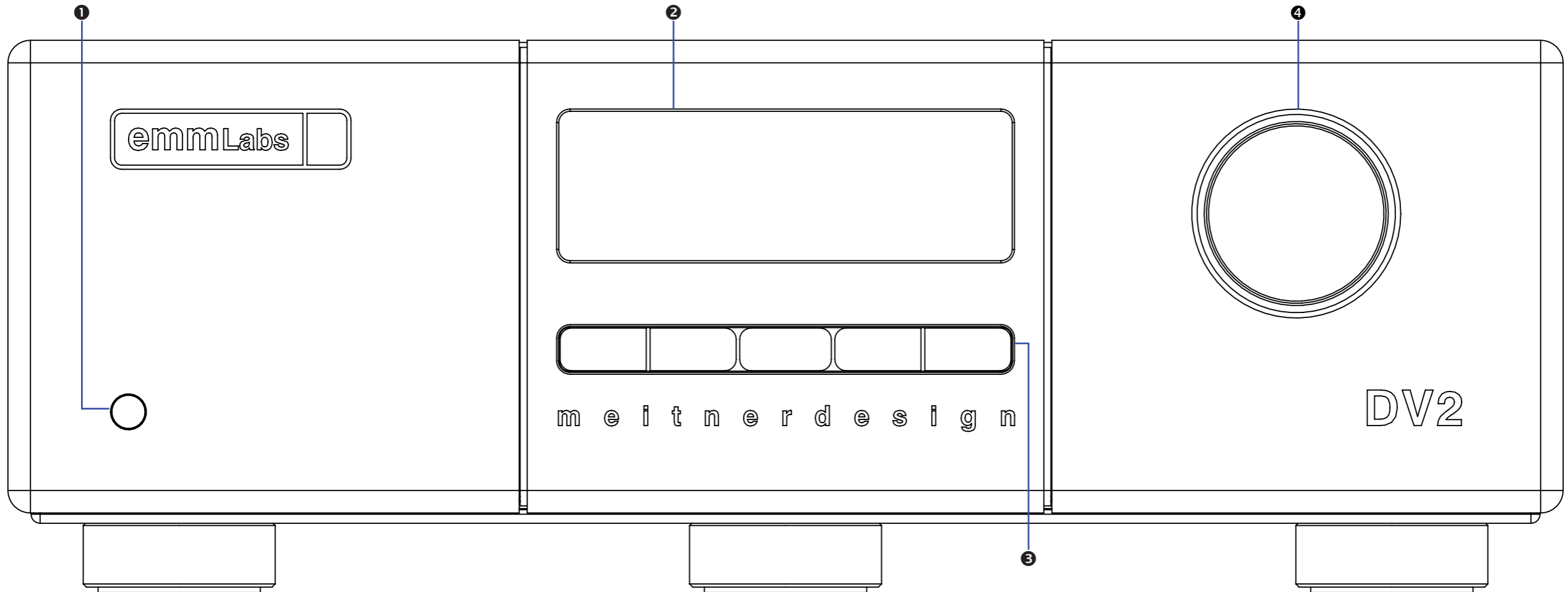

1. *Standby/Power-Save button:*  
Toggles the operation between on and power-save mode. In power save mode the remote control and all front panel functions become inactive.
2. *Display*
3. *Button Bar:*  
Context sensitive function buttons
4. *Volume Control*

## Rear Panel &amp; Functions

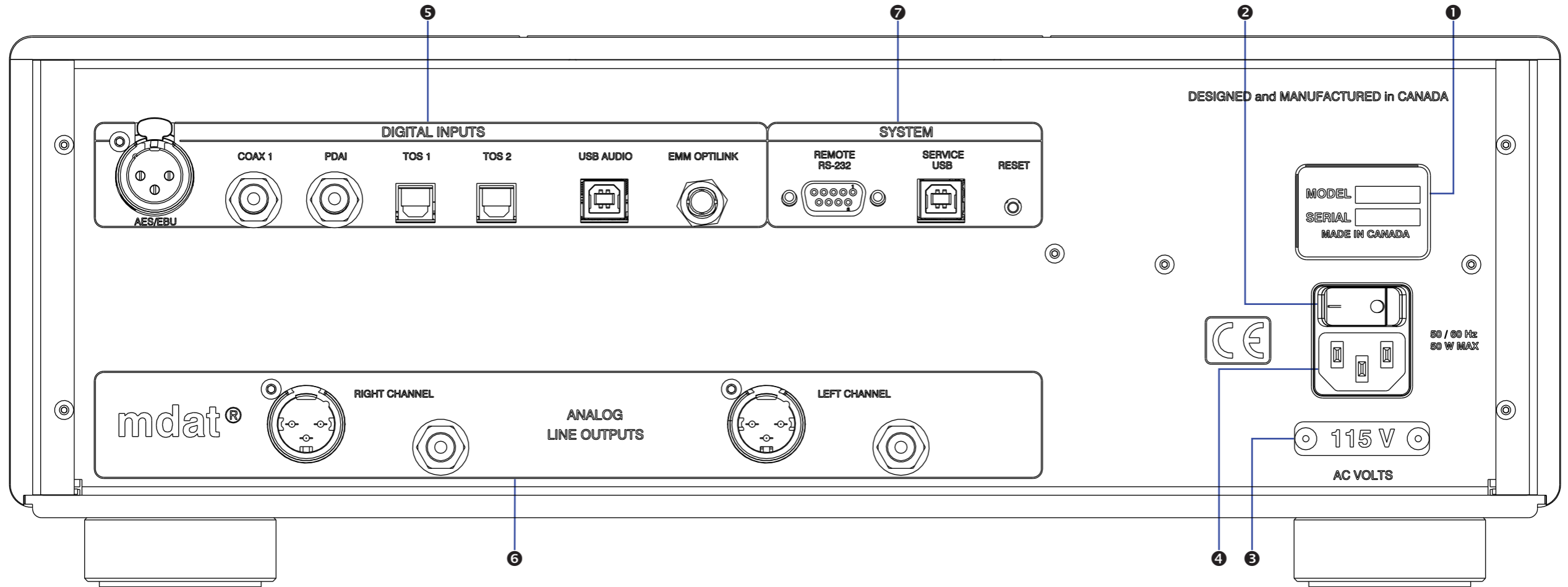
1. *Product model and serial number indicator:*

Warranty void if model/serial number indicator is not attached to unit, missing or damaged whereby serial number cannot be seen.

2. *Main Power Switch*3. *Product VOLTAGE indicator:*

Indicates working voltage of the DV2. Only use with indicated line voltage.

4. *Main Power connector*

## Rear Panel & Functions

5. *Digital Inputs (All inputs support up to 24bit, 192kHz and DSD. USB Audio input additionally supports DXD and DSD/DSD64 and 2xDSD/DSD128 streaming):*
  - EMM Otilink: input for interconnection with an EMM Labs transport.
  - USB Audio: PCM, DXD, DSD & MQA® from computer, media player, server
  - AES/EBU: AES/EBU (XLR) PCM digital audio input.
  - COAX: SPDIF (RCA) format PCM digital audio input.
  - PDAI: SPDIF (RCA) format PCM digital audio input.
  - TOS1: SPDIF (TOSLINK) format PCM digital audio input.
  - TOS2: SPDIF (TOSLINK) format PCM digital audio input.
  
6. *Analog Line Output:*
  - Left and Right Balanced (XLR) Connectors
  - Left and Right Un-Balanced (RCA) Connectors
  - Output Line Level with 0dBfs signal on AES/EBU input (High/Low):
    - XLR outputs: 7.0/5.0V (+19.1/16.2dBu)
    - RCA outputs: 3.5/2.5V ((+13.1/10.2dBu)
  
7. *System*
  - Remote:
    - Wired RS232: RS232 communication port. See Appendix A.
  - Service:
    - USB data port for firmware upgrades (see separate USB update instructions)
    - RESET button used to temporarily access the backup firmware. Only for diagnostic purposes. Should not be used during normal operation.

## Main Screen

Main screen shows input and sample rate information plus the 4 main functions:

### 1. MUTE

Mute the DV2 by pressing the button directly below the “MUTE” function on the display. When muted the display will show “MUTED” and it will be highlighted.

### 2. UNITS

Use the “UNITS” display button directly below the “UNITS” function on the display to change how the volume is displayed. The two choices are standard 100 step EMM style or in dBs.

### 3. MENU

Engage the “MENU” function by pressing the button directly below it and a pop-up menu will open with 5 features (details in following pages):

- CONTRAST & BRIGHTNESS - DV2 display brightness and contrast controls
- VOLUME PRESETS - Save up to 3 volume presets for instant recall
- ASSIGN INPUT BUTTON - assigns a fixed input to input toggles
- REMOVE ASSIGNMENTS - removes all input button assignments
- RESET SETTINGS - reverts the settings back to factory default.

Output gain and Optilink settings are set here as well.

### 4. Input Toggle Back (◀) or Forward (▶)

Toggle/scroll through the DV2 source inputs using the back (◀) button or forward (▶) button.

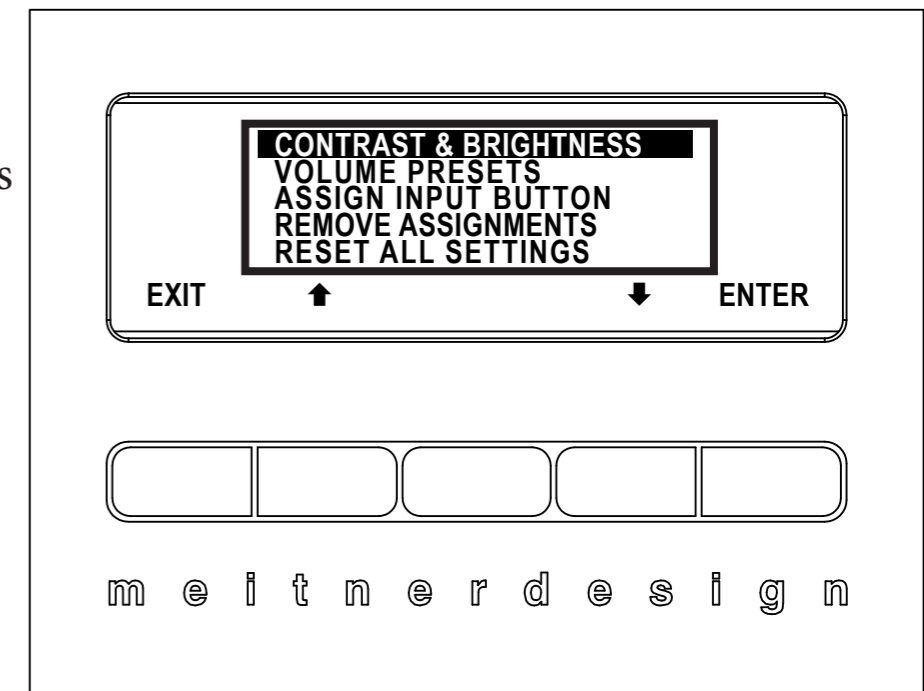
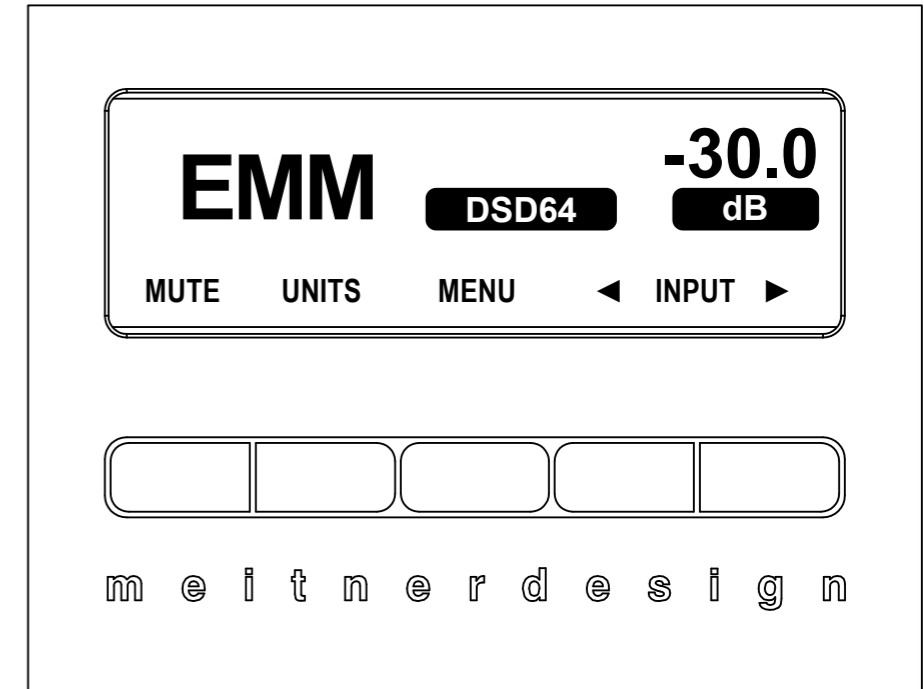

### Menu Details

Use the up/down arrow keys to select one of the 5 features from the pop-up menu. Press the “ENTER” button to select. Feature details:

#### 1. CONTRAST & BRIGHTNESS

Use the “CONTRAST & BRIGHTNESS” feature to change the display brightness and contrast settings. Starting with the brightness setting, use the left and right arrow buttons to adjust the level of brightness then press the “SAVE” button to save the brightness setting. Press the “NEXT” button to access the “CONTRAST” control. The process to set and save the contrast setting is the same as setting the brightness. Press the “EXIT” button to exit the “CONTRAST & BRIGHTNESS” controls.

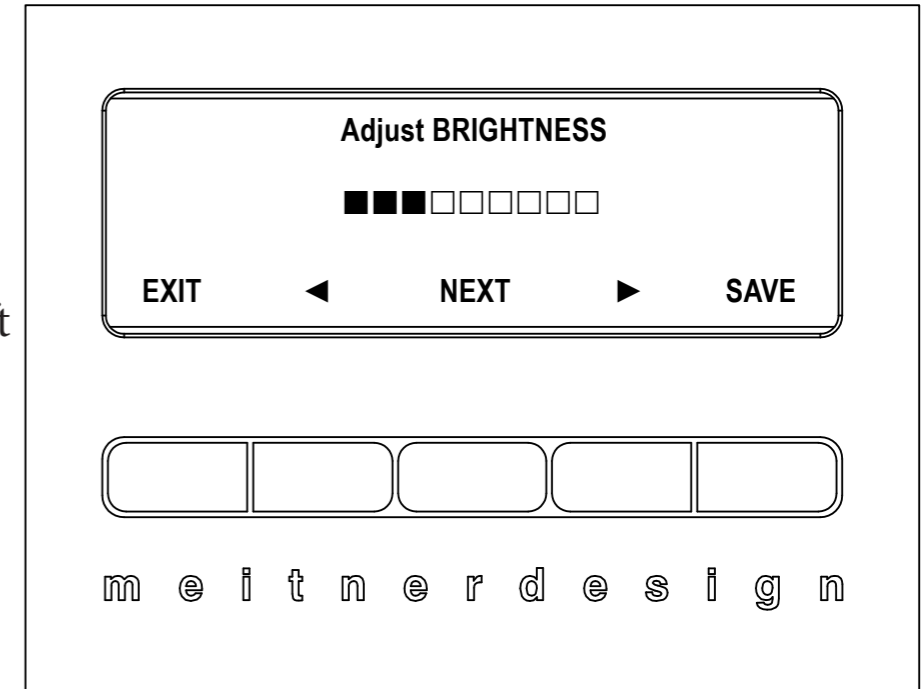

#### 2. VOLUME PRESETS

You can save up to three volume presets and instantly recall them using the remote. Select a volume setting using the volume knob or remote. Press the A, B or C preset buttons to assign. Using the remote, you can instantly recall the presets by pressing buttons 1 for preset A, 2 for preset B and 3 for preset C.

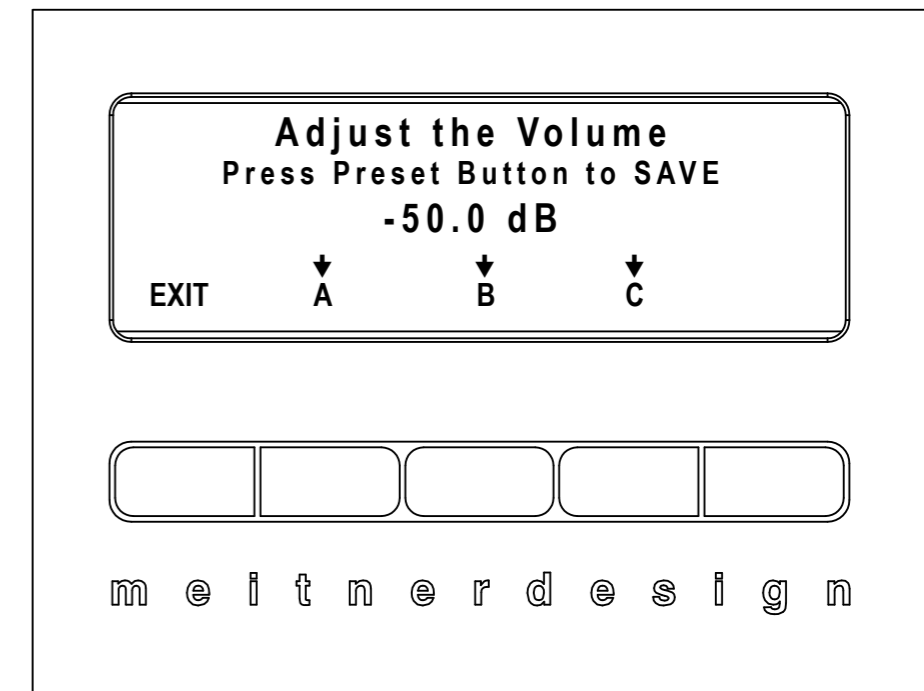

## Menu Options

### 2. ASSIGN INPUT BUTTON

Using the “ASSIGN INPUT 1” & “ASSIGN INPUT 2” feature, you can directly assign up to two DV2 inputs to the back (◀) and forward (▶) input scroll/toggle buttons. First select either “ASSIGN INPUT 1” or “ASSIGN INPUT 2” from the main pop-up menu. You will be shown a list of available inputs to assign to the button. Select an input from the list by using the up (↑) and down (↓) scroll buttons. Save the input selection to the button by pressing the “SAVE” button. You can assign just one or both inputs. If you just assign one input to a button, the other button can still be used to scroll through the DV2’s inputs. Press the “EXIT” button to exit the “ASSIGN INPUT” controls. You can also assign the buttons directly from the front panel by pressing and holding the (◀) and (▶) until you see the list of available inputs.

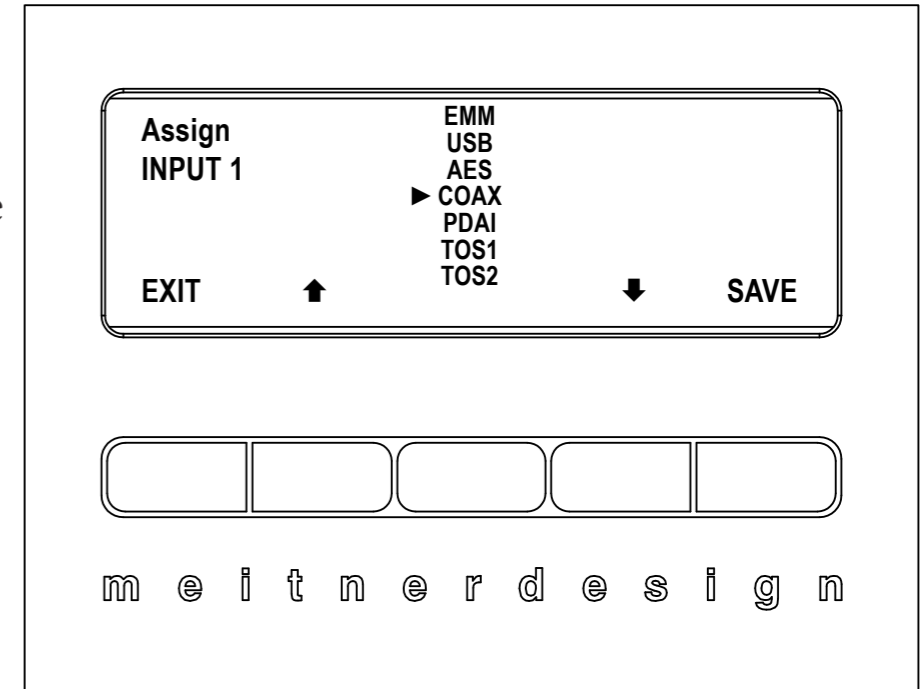

### 3. REMOVE ASSIGNMENTS

The REMOVE ASSIGNMENTS feature allows you to remove previously assigned inputs individually. Press the button below the input you want to remove and this will remove the input assigned to it. To remove all assigned inputs, press the “REMOVE ALL” button. Press the “EXIT” button to exit the REMOVE ASSIGNMENTS controls.

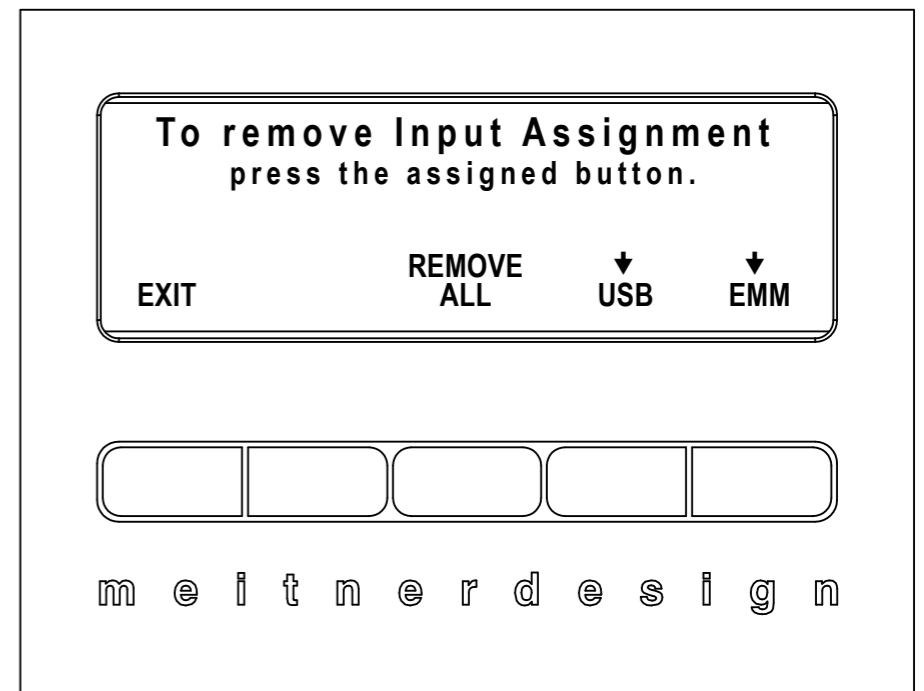

## Menu Options

### 4. RESET SETTINGS

Press the “EXIT” button to exit the RESET SETTINGS menu.

Press the “GAIN” button to set the output gain to “LOW” or “HIGH”.

Press “RS232” button to set the RS232 behavior. Set to “STREAMER” for use with the NS1 Streamer. Set to “REMOTE” to work as a standard RS232 port.

Press the “RESET” button to reset the DV2 back to factory defaults.

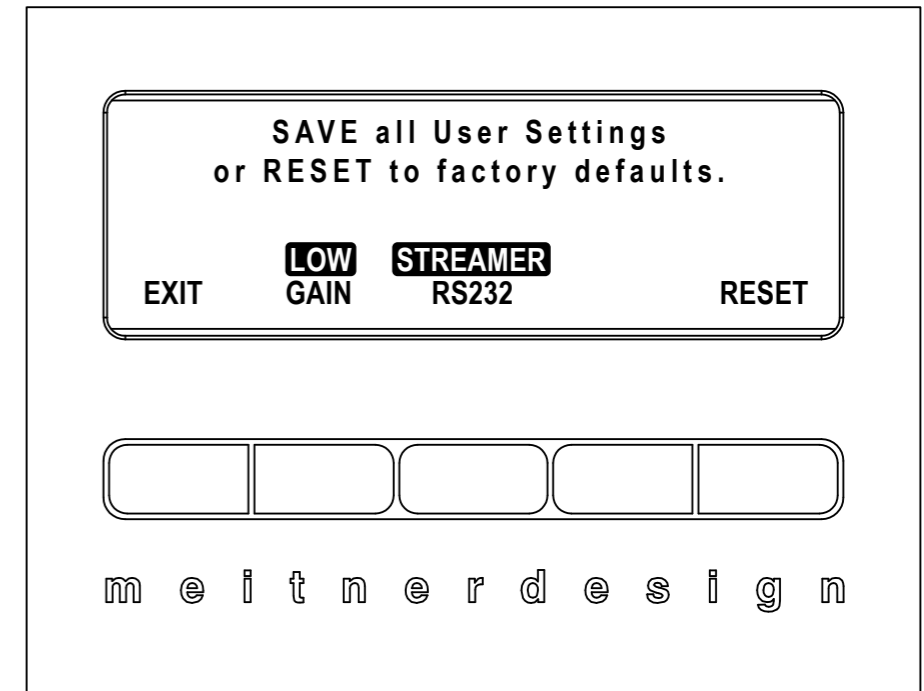

## Basic Operations and Input Connections

The main screen shows the current input that is being used and sample rate. The sample rate is shown when a valid digital audio stream is detected. If there is nothing connected or there is no valid audio stream "NO LOCK" is displayed. Along with sample rate, the type of MQA® stream is also displayed.

*The DV2 has a host of digital inputs :*

**EMM Optilink(EMM):** Proprietary ST glass optical connection to EMM Labs CD/SACD transport and players like the TX2, TSDX XDS1 V2, TSD1 and XDS1.

**USB Audio (USB) :** USB Audio connection supports up to 24bit 192kHz PCM, DXD 352 and 384kHz, DSD64 and DSD128 (2xDSD) and MQA® using USB 2.0 cables

**AES :** Balanced digital interface supports up to 24bit 192kHz and DSD via XLR 110Ω digital cables.

**COAX :** COAX S/PDIF interface which supports up to 24bit 192kHz and DSD via RCA 75Ω digital cables.

**PDAI :** Same as COAX S/PDIF interface.

**TOS1 :** TOSLINK optical interface supports up to 24bit 192kHz and DSD via TOSLINK optical interface.

**TOS2 :** Same as TOS1.

Connect the source digital outputs to the appropriate DV2 digital inputs and select the appropriate input using the input toggle/scroll back (◀) or forward (▶) buttons.

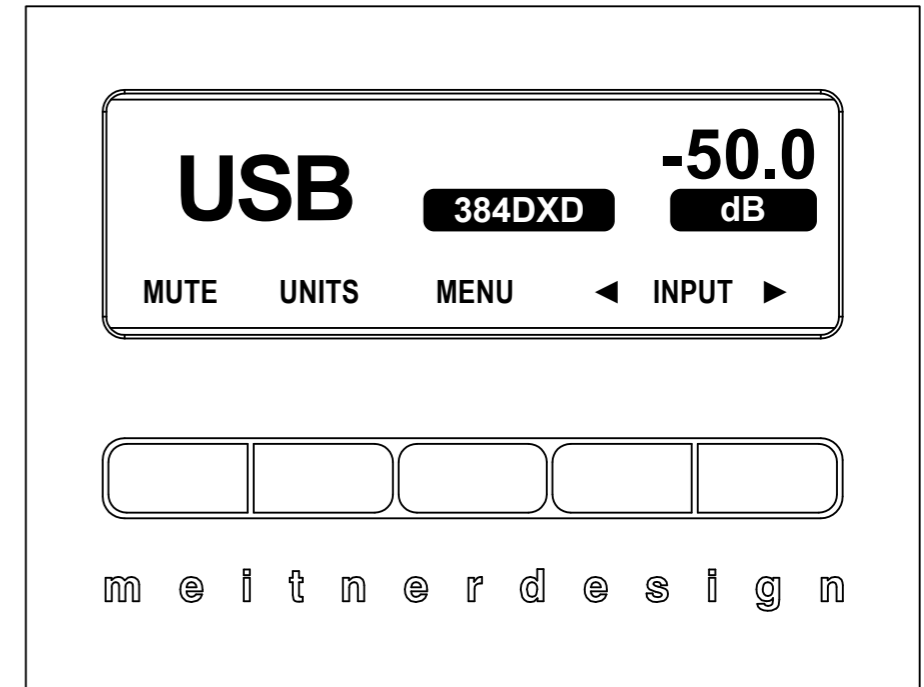
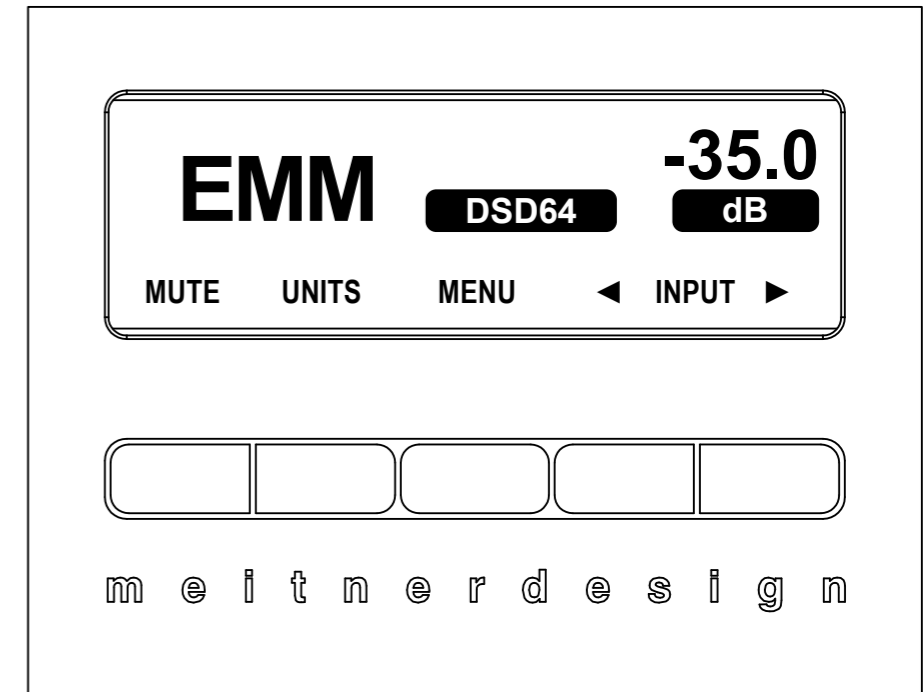

## Basic Operations and Input Connections

*TX2 and DV2 Quick Connect:*

Connect the EMM Optilink cable from the TX2 to DV2 (same for TSDX/XDS1/TSD1)

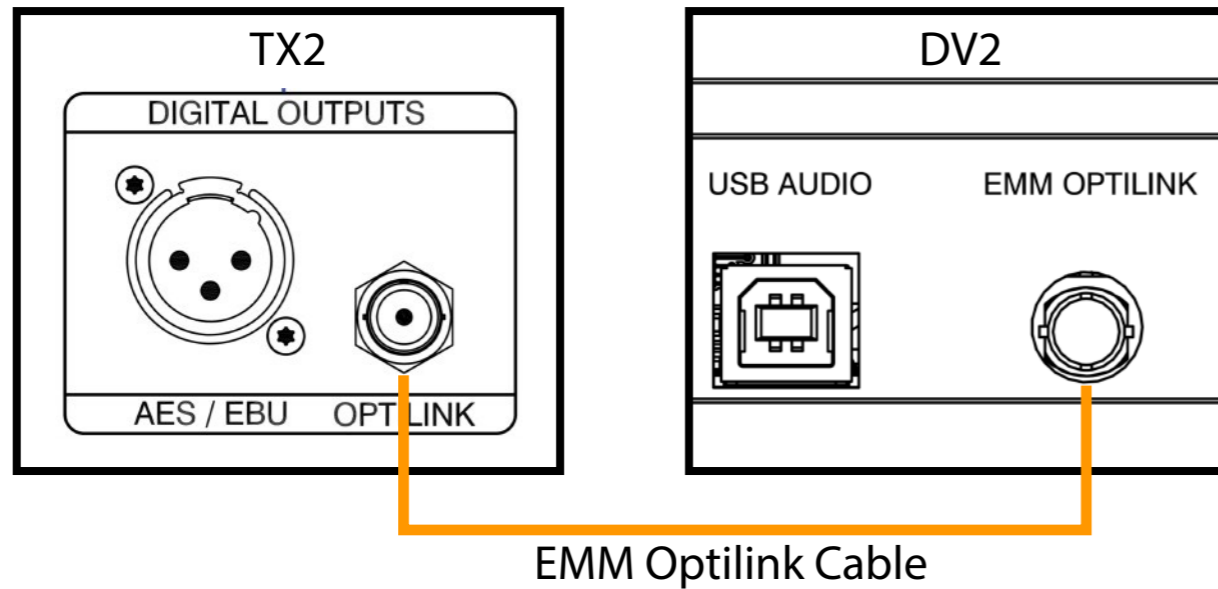

Additionally for the TSD1 External Clock switch must be set to internal:

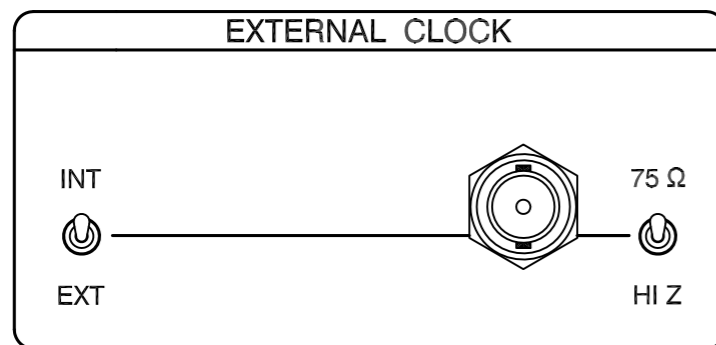

Using either the remote or the front panel of the DV2 select EMM Link. The DV2 display will show the appropriate sample rate when locked.

## Basic Operations and Input Connections

### *DV2 USB Audio:*

1. First, use only an appropriate well-shielded certified USB 2.0\* cable to connect from any USB digital audio source component's (computer, laptop, media player etc.) output to the DV2's **USB Audio** input (**NOT the USB service port**).
2. The DV2's USB Audio interface uses the B-type USB connector similar to connectors used on printers. Please see image below:



3. Select the USB Audio input using the input selector buttons or remote.
4. For MAC OSX systems, no driver is needed. OSX has the appropriate USB driver already installed.
5. For Windows systems install the provided USB audio driver or download from the product specific section of our website <https://www.emmlabs.com> located in the Please read and carefully follow the driver installation instructions.
6. Kernel, ASIO and WASAPI drivers will be installed.

For Windows Media Player playback; in Windows Control Panel set the default sound playback to the listed DV2 USB Audio device as per the installation instructions.

\*Not using proper USB cables will cause audio issues between digital source and DAC.

## Basic Operations and Input Connections

In general for most audio applications you will be able to select the DV2 USB Audio device from within the application. Then choose the appropriate drivers, ASIO, WASAPI or Kernal, you want to use with it.

### DSD, DXD and MQA® Audio

1. The DV2 currently supports DSD (DSD64), 2xDSD (DSD128), DXD and MQA® audio file streaming and conversion over USB. DSD streaming uses the DoP specification.
2. Please make sure that your DV2 has the latest installed firmware and drivers. If unsure please email [support@emmlabs.com](mailto:support@emmlabs.com) with your DV2 serial number and our engineers will be able to tell you if you need to update your unit.
3. DSD and 2xDSD audio files have the extension DFF and DST. DXD files (PCM 352 and 384kHz) and MQA® are available in standard filetypes like WAV or FLAC. You can use any media player like JRiver, Roon, Audivarna or a standalone media/network player to play these files to the DV2.
4. Every media player will have specific installation and setup procedures for enabling DSD, DXD and MQA® file streaming. Please consult its specific software manual to properly enable these features.
5. Some software/hardware manufacturers also provide quickstart and software setup guides. Please consult these prior to installation.

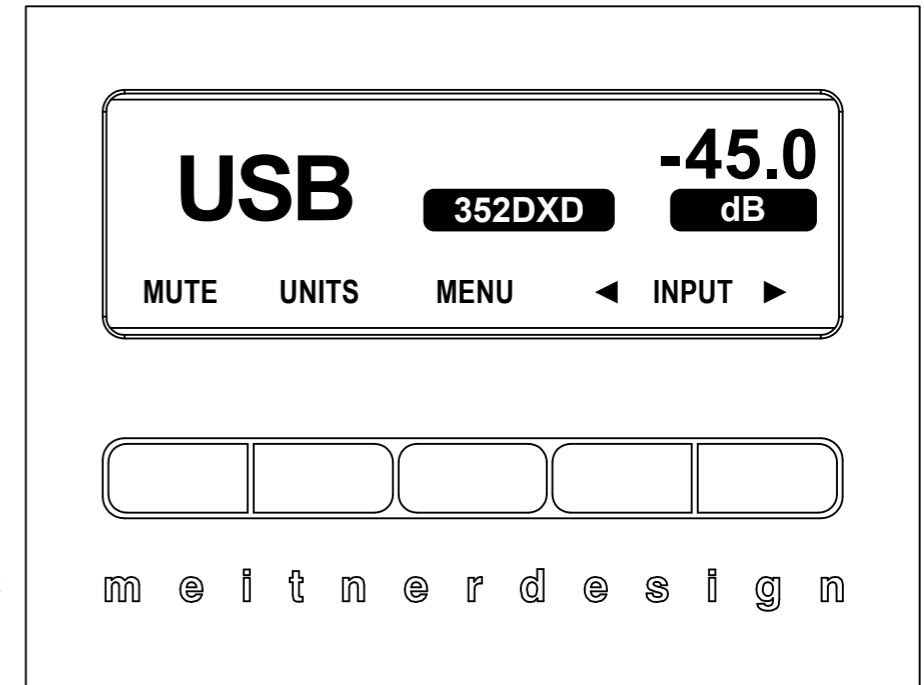
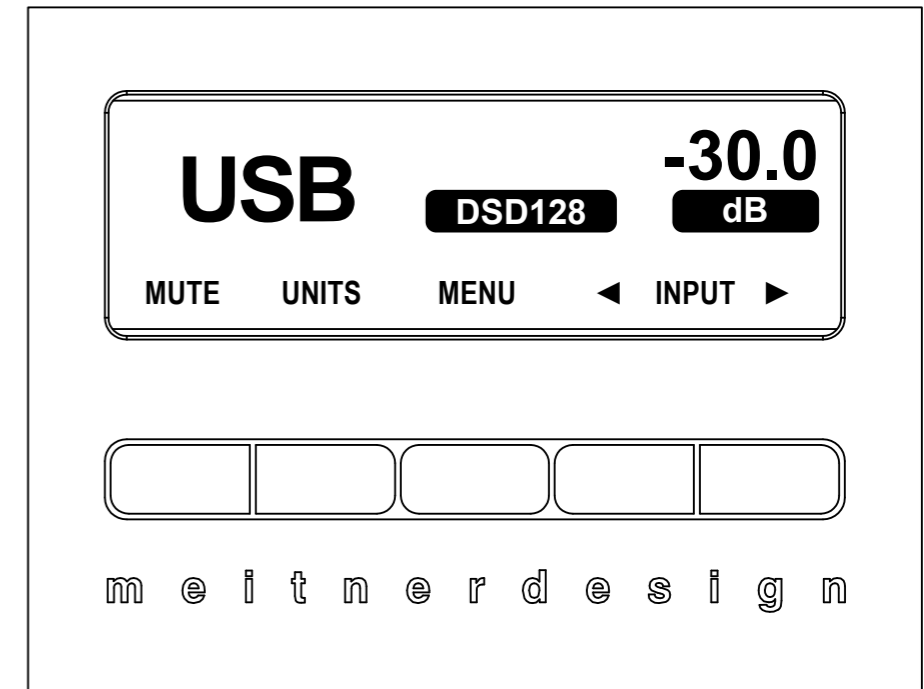

## DSD, DXD and MQA® Audio

- When setup correctly samplerate and file types will be displayed on the DV2 display.
- Depending on the digital source, when playback of DSD material is paused or stopped the display may indicate a PCM samplerate rather than DSD. This is normal for DoP functionality. Once playback is restarted the DV2's display will once again show that it is receiving DSD information.
- The DV2 supports the full unfolding of MQA® audio files using its custom implementation of the MQA® decoder and renderer.
- Depending on the media player and source material, the display will show the type of MQA® file ('MQA' or 'MQA Studio') and the maximum unfolded sample rate. 'MQA' or 'MQA Studio' indicates that the product is decoding and playing an MQA® stream or file, and denotes provenance to ensure that the sound is identical to that of the source material. 'MQA Studio' indicates it is playing an MQA® Studio file, which has either been approved in the studio by the artist/producer or has been verified by the copyright owner.

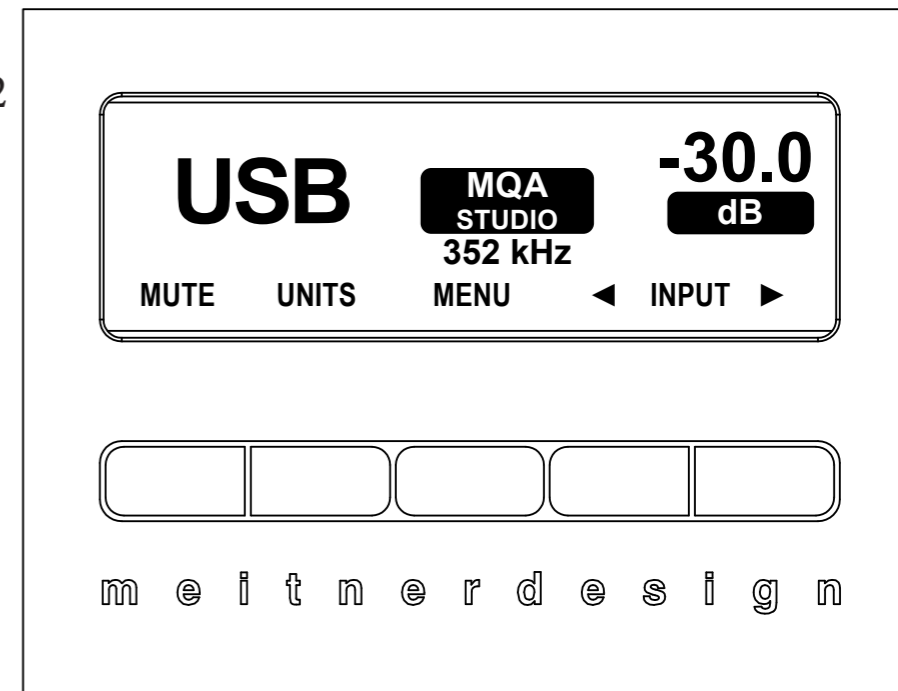

MQA® (Master Quality Authenticated) is an award-winning British technology that delivers the sound of the original master recording. The master MQA® file is fully authenticated and is small enough to stream or download.

Visit [mqa.co.uk](http://mqa.co.uk) for more information.

## Infrared Remote Control

The remote control allows wireless control of the DV2 functions.

**POLARITY:** Toggles the analog output polarity. Polarity inversion is performed in the digital domain. When engaged a “-” will be displayed in front of the input name.

**DISPLAY:** Toggles the front panel display brightness settings on the DV2

**Input Buttons:**

- EMM : Selects the EMM Optilink input
- USB : Selects the USB Audio input
- AES : Selects the AES/EBU input via balanced digital XLR
- COAX : Selects SPDIF input via digital COAX/RCA
- TOS : Toggles between the two TOSLINK SPDIF inputs
- AUX : Selects PDAI SPDIF digital input via COAX/RCA

**INPUT:** Toggles through all the digital inputs

**MUTE:** Mutes the DV2 outputs

**Presets Buttons:**

- A :Selects Volume Preset A
- B :Selects Volume Preset B
- C :Selects Volume Preset C

**VOL:** Use the VOL+/- buttons to increase/decrease the output of the DV2

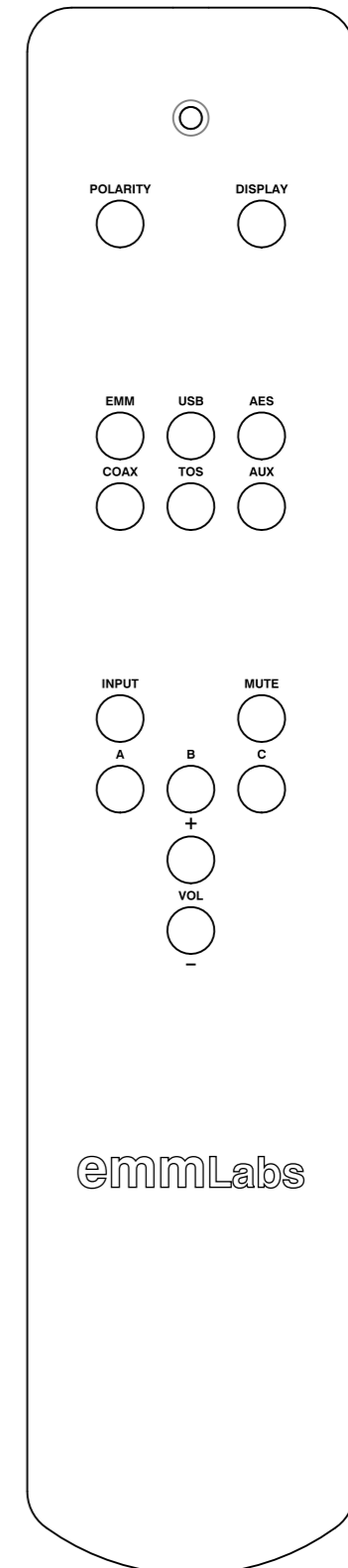

## Infrared Remote Control (Original)

The remote control provides combined functions for the DV2 and associated EMM Labs products:

**DAC:** Toggles the front panel display brightness settings on the DV2.

**DISC:** Toggles the front panel display brightness settings on associated EMM Labs transports like the TX2.

**INPUT:** Digital source input selection:

- **EMM** : Selects the EMM Optilink input.
- **PC** : Selects the USB Audio input.
- **AES** : Selects the AES/EBU input via balanced digital XLR
- **COAX** : Selects SPDIF input via digital COAX/RCA
- **TOS** : Toggles between the two TOSLINK SPDIF inputs
- **PDAI** : Selects PDAI SPDIF digital input via COAX/RCA

**POLARITY:** Toggles the analog output polarity. Polarity inversion is performed in the digital domain. When engaged a “-” will be displayed in front of the input name.

**MUTE:** Mutes the DV2 outputs.

**VOLUME:** Use the VOL+/- buttons to increase/decrease the output of the DV2.

**TRANSPORT:** Use the transport functions to control an EMM transport eg. TX2.

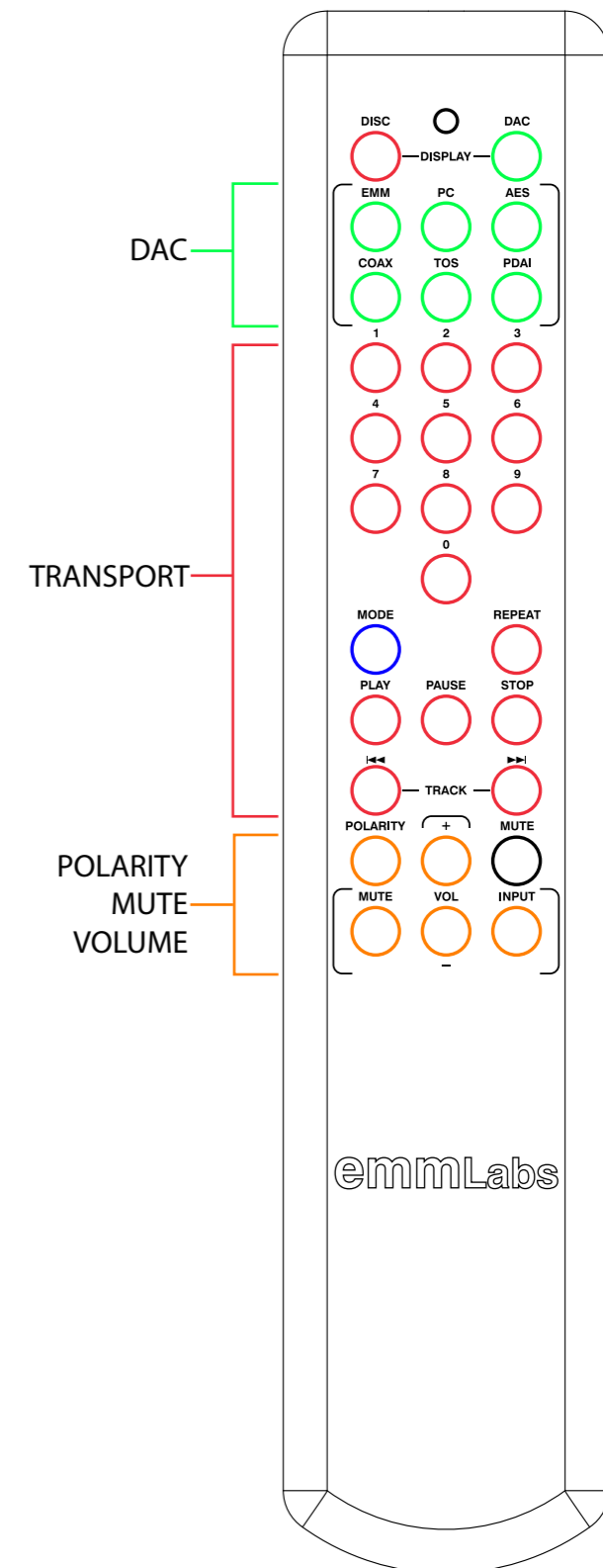

## Infrared Remote Control (Original)

**MODE:** When the MODE button is pressed, the LED will turn on for 10 seconds indicating access to additional functions. While active, only buttons 1, 2, 3 and PLAY are selectable:

- Pressing 1 selects Volume Preset A
- Pressing 2 selects Volume Preset B
- Pressing 3 selects Volume Preset C
- Pressing PLAY toggles the Mode selection function (SACD 2-channel/SACD Multi-channel/CD) for EMM Labs transports eg. TX2.

All other buttons are disabled. Once a selection is made or the 10 second window passes, the LED will turn off and remote will return to its normal operation.

